

light / 06



miloox®

[miloox.com](http://miloox.com)

be sparkling with us!

# DESIGNERS

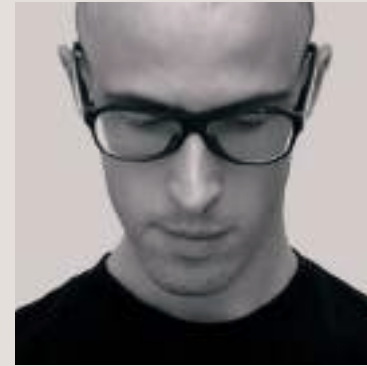

DAVIDE  
NEGRI

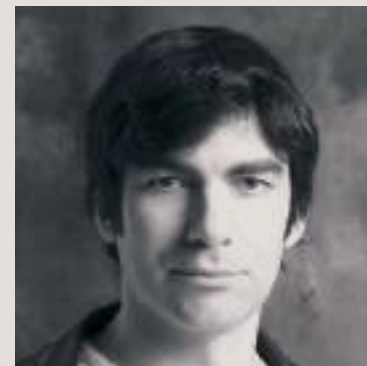

GERARDO  
MARI

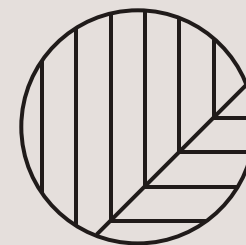

**Acero.**

ACERO  
DESIGN  
STUDIO

# AWARDS

WINNER



MIKADO  
and  
ALADINO



La possibilità di rotazione dei bracci della lampada **MIKADO** consente di ottenere diversi tipi di composizione a parete. Questo, insieme all'estetica contemporanea le ha valso il **Good Design Award 2020**.

**ALADINO** è una lampada che può essere installata a soffitto con diverse configurazioni a seconda delle necessità. Questa libertà di composizione le ha valso il **Good Design Award 2020**.

Thanks to its arm rotation, the **MIKADO** lamp can be used in different wall combinations. This, along with its contemporary look, has earned it the **Good Design Award 2020**.

**ALADINO** is a lamp that can be mounted on the ceiling in different configurations, depending on your needs. This freedom of composition has earned it the **Good Design Award 2020**.

Die Möglichkeit, die Arme der **MIKADO**-Leuchte zu drehen, ermöglicht es, verschiedene Arten von Wandkompositionen zu erhalten. Dies, zusammen mit der zeitgenössischen Ästhetik, brachte ihr den **Good Design Award 2020** ein.

**ALADINO** ist eine Leuchte, die je nach Bedarf in verschiedenen Konfigurationen an der Decke installiert werden kann. Diese Freiheit in der Gestaltung brachte ihr den **Good Design Award 2020** ein.

La possibilité de rotation des bras de la lampe **MIKADO** permet différents types de compositions murales. Cette caractéristique, associée à une esthétique contemporaine, lui a valu le **Good Design Award 2020**.

**ALADINO** est une lampe qui peut être installée au plafond dans différentes configurations et en fonction des nécessités. Cette liberté de composition lui a valu le **Good Design Award 2020**.



# KIKA

## KIKA

L'equilibrio della casualità.  
In Kika il posizionamento randomico delle sfere in vetro opalino sulle sottili bacchette liquirizia è pensato per trovare armonia nel caos e dare così bilanciamento alla composizione, allargando inoltre lo spazio illuminato. La spessa bacchetta centrale in oro spazzolato dona preziosità e congiunge tutti gli elementi, facendosi portavoce della connessione fra diverse nature.

The balance of randomness.  
In Kika, the random position of opal glass spheres on thin liquorice rods is designed to find harmony in chaos and balance out the composition, while expanding the illuminated space. The thick central brushed gold rod makes the unit precious and connects all the elements, by carrying forward the connection between different natures.

Das Gleichgewicht des Zufalls.  
Bei Kika soll die zufällige Anordnung der Opalglaskugeln auf den dünnen lakritzfarbenen Stangen das Chaos harmonisieren und der Komposition ein Gleichgewicht verleihen, während sie gleichzeitig den beleuchteten Raum vergrößert. Der dicke zentrale Stab aus gebürstetem Gold verleiht Kostbarkeit und verbindet alle Elemente, indem er die Verbindung zwischen den verschiedenen Naturen verdeutlicht.

L'équilibre du hasard.  
Dans Kika, le positionnement aléatoire de sphères de verre opaline sur de fines tiges couleur réglisse, est conçu pour créer l'harmonie à partir du chaos et équilibrer ainsi la composition, tout en étendant l'espace éclairé. L'épaisse tige centrale or brossé ajoute en raffinement et relie tous les éléments, devenant ainsi l'expression du lien existant entre différentes natures.



# KIKA

SUSPENSION

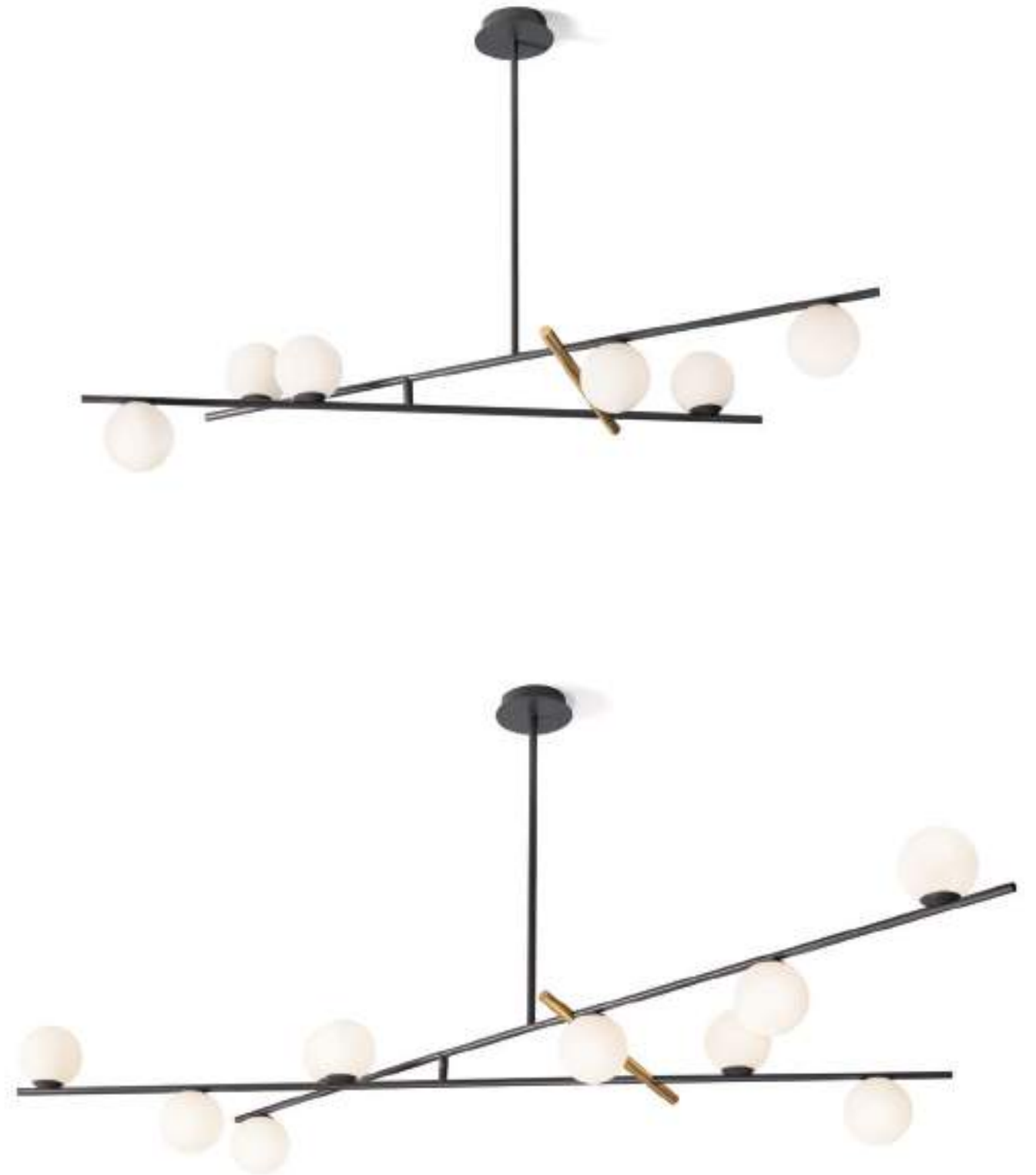



# KIKA

TABLE



# KIKA

TABLE



# KIKA

WALL LAMP





# KIKA

WALL LAMP

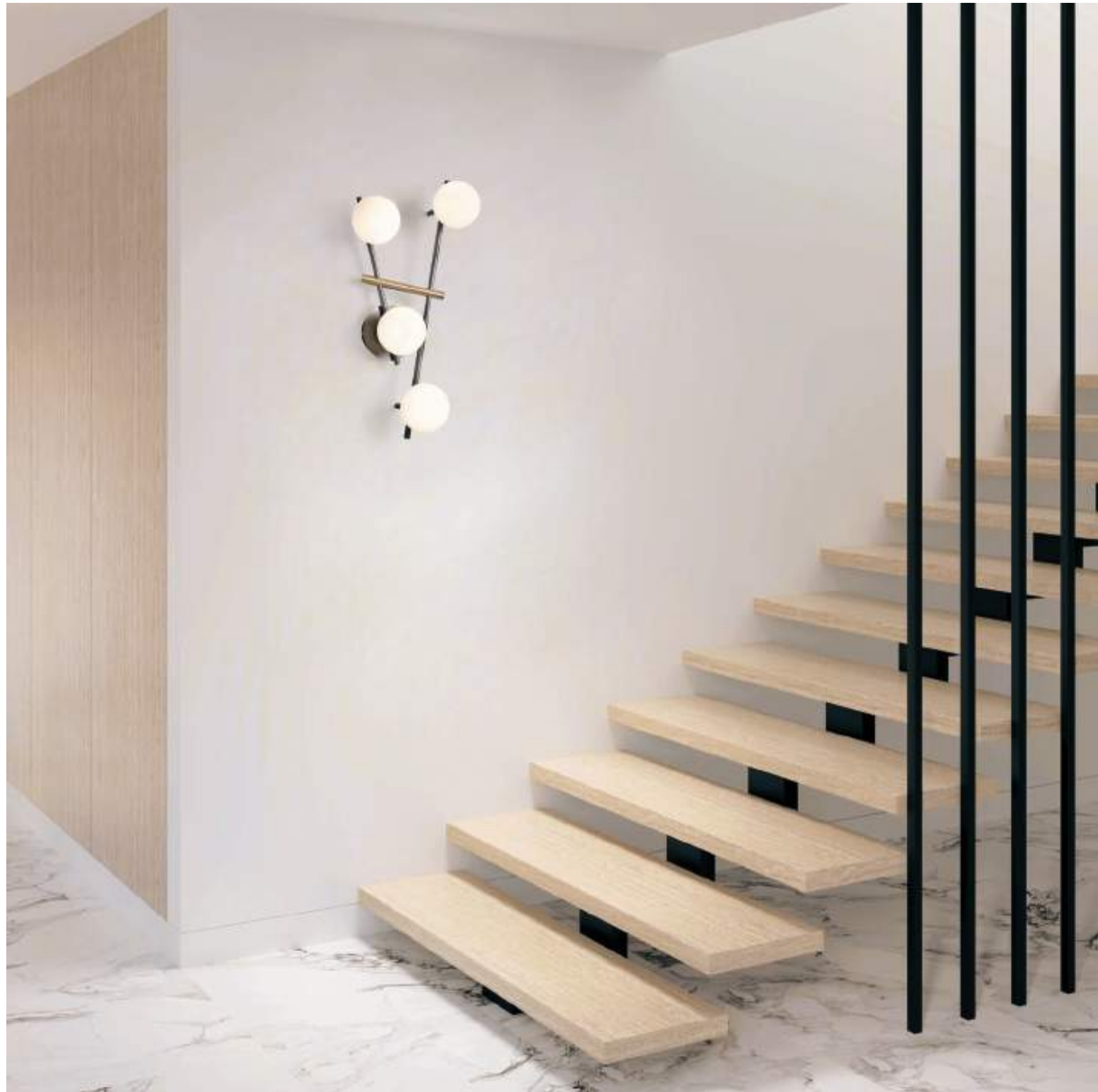

# KIKA

CEILING LAMP





KIKA  
CEILING LAMP



KIKA  
FLOOR LAMP







# KIKA

FLOOR LAMP

49

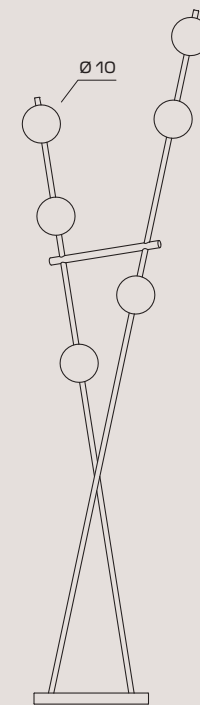

182

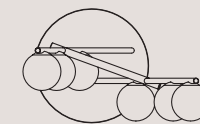

Ø 30

Lampada da terra in metallo,  
in colore Liquirizia Nera  
con particolare in Oro spazzolato.  
Vetri soffiati bianco latte.  
Lampada dotata di Dimmer.

Metal floor lamp.  
Licorice Black colour  
with brushed Gold detail.  
Milk-white blown glass.  
Dimmerable.

Stehleuchte aus Metall in Lakritzschwarz  
mit Details in gebürstetem Gold.  
Milchweißes mundgeblasenes Glas.  
Die Lampe ist mit einem  
Dimmer ausgestattet.

Lampadaire en métal.  
couleur Liquirizia Nera  
avec détails or brossé.  
Verre soufflé blanc laiteux.  
Lampe équipée d'un variateur.

CODE 1744.335

COLOR ● Black Licorice

#### LIGHT SOURCE

Source G9 LED DIMMABLE | Power 6 x max 10w  
Max bulb size: Ø20xH60mm



# KIKA

## SUSPENSION

Lampada da sospensione in metallo,  
in colore Liquirizia Nera  
con particolare in Oro spazzolato.  
Vetri soffiati bianco latte.

Metal pendant lamp.  
Licorice Black colour  
with brushed Gold detail.  
Milk-white blown glass.

Pendelleuchte aus Metall  
in Lakritzschwarz mit Details  
in gebürstetem Gold.  
Milchweißes mundgeblasenes Glas.

Suspension en métal  
couleur Liquirizia Nera  
avec détails or brossé.  
Verre soufflé blanc laiteux.

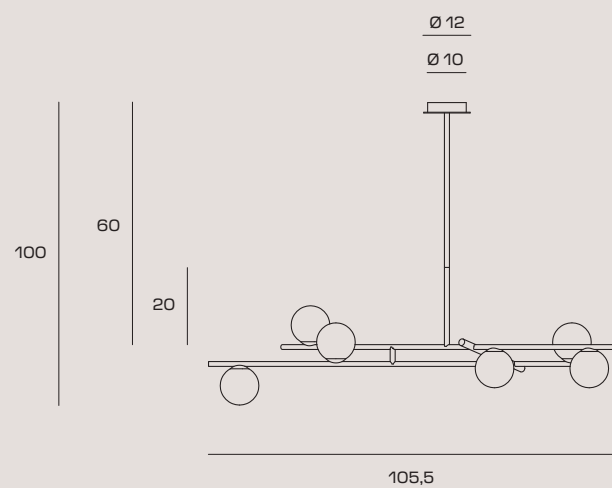
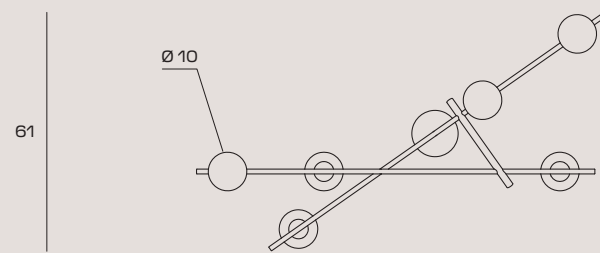

CODE	1744.329
COLOR	● Black Licorice

### LIGHT SOURCE

Source G9 LED | Power 6 x max 10w  
Max bulb size: Ø20xH60mm



# KIKA

## SUSPENSION

Lampada da sospensione in metallo,  
in colore Liquirizia Nera  
con particolare in Oro spazzolato.  
Vetri soffiati bianco latte.

Metal pendant lamp.  
Licorice Black colour  
with brushed Gold detail.  
Milk-white blown glass.

Pendelleuchte aus Metall  
in Lakritzschwarz mit Details  
in gebürstetem Gold.  
Milchweißes mundgeblasenes Glas.

Suspension en métal  
couleur Liquirizia Nera  
avec détails or brossé.  
Verre soufflé blanc laiteux.

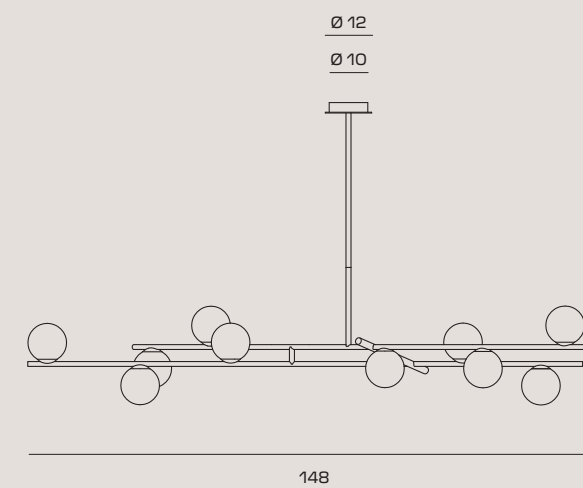
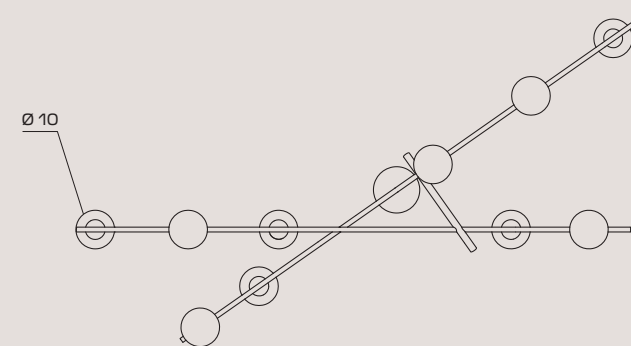

CODE	1744.330
COLOR	● Black Licorice

### LIGHT SOURCE

Source G9 LED | Power 10 x max 10w  
Max bulb size: Ø20xH60mm



# KIKA

## TABLE

Lampada da tavolo in metallo,  
in colore Liquirizia Nera  
con particolare in Oro spazzolato.  
Vetri soffiati bianco latte.  
Lampada dotata di Dimmer.

Metal table lamp.  
Liquorice Black colour  
with brushed Gold detail.  
Milk-white blown glass.  
Dimmerable.

Tischleuchte aus Metall  
in Lakritzschwarz mit Details  
in gebürstetem Gold.  
Milchweißes mundgeblasenes Glas.  
Die Lampe ist mit einem  
Dimmer ausgestattet.

Lampe de table en métal.  
couleur Liquirizia Nera  
avec détails or brossé.  
Verre soufflé blanc laiteux.  
Lampe équipée d'un variateur.

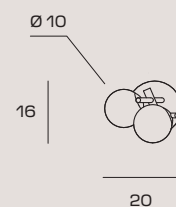
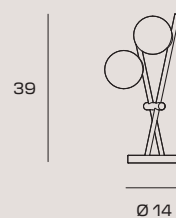

# KIKA

## TABLE

Lampada da tavolo in metallo,  
in colore Liquirizia Nera  
con particolare in Oro spazzolato.  
Vetri soffiati bianco latte.  
Lampada dotata di Dimmer.

Metal table lamp.  
Liquorice Black colour  
with brushed Gold detail.  
Milk-white blown glass.  
Dimmerable.

Tischleuchte aus Metall  
in Lakritzschwarz mit Details  
in gebürstetem Gold.  
Milchweißes mundgeblasenes Glas.  
Die Lampe ist mit einem  
Dimmer ausgestattet.

Lampe de table en métal.  
couleur Liquirizia Nera  
avec détails or brossé.  
Verre soufflé blanc laiteux.  
Lampe équipée d'un variateur.

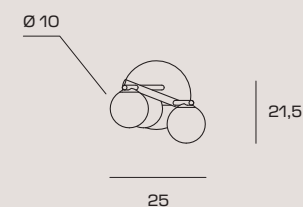
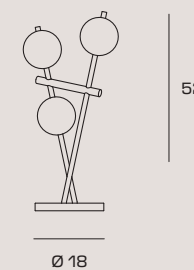

CODE	1744.333
COLOR	● Black Licorice

### LIGHT SOURCE

Source G9 LED DIMMABLE | Power 2 x max 10w  
Max bulb size: Ø20xH60mm



CODE	1744.334
COLOR	● Black Licorice

### LIGHT SOURCE

Source G9 LED DIMMABLE | Power 3 x max 10w  
Max bulb size: Ø20xH60mm



# KIKA

## WALL LAMP

Lampada da parete in metallo,  
in colore Liquirizia Nera  
con particolare in Oro spazzolato.  
Vetri soffiati bianco latte.

Metal wall lamp.  
Licorice Black colour  
with brushed Gold detail.  
Milk-white blown glass.

Wandleuchte aus Metall  
in Lakritzschwarz mit Details  
in gebürstetem Gold.  
Milchweißes mundgeblasenes Glas.

Applique en métal,  
couleur Liquirizia Nera  
avec détails or brossé.  
Verre soufflé blanc laiteux.

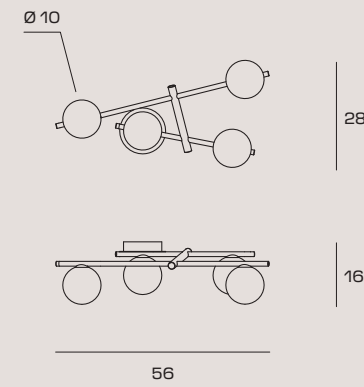
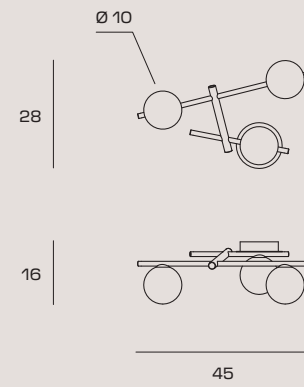

# KIKA

## WALL LAMP

Lampada da parete in metallo,  
in colore Liquirizia Nera  
con particolare in Oro spazzolato.  
Vetri soffiati bianco latte.

Metal wall lamp.  
Licorice Black colour  
with brushed Gold detail.  
Milk-white blown glass.

Wandleuchte aus Metall  
in Lakritzschwarz mit Details  
in gebürstetem Gold.  
Milchweißes mundgeblasenes Glas.

Applique en métal,  
couleur Liquirizia Nera  
avec détails or brossé.  
Verre soufflé blanc laiteux.

CODE	1744.331
COLOR	● Black Licorice

### LIGHT SOURCE



Source G9 LED | Power 3 x max 10w  
Max bulb size: Ø20xH60mm



CODE	1744.332
COLOR	● Black Licorice

### LIGHT SOURCE



Source G9 LED | Power 4 x max 10w  
Max bulb size: Ø20xH60mm

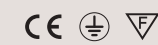

# KIKA

## CEILING LAMP

Lampada da soffitto in metallo,  
in colore Liquirizia Nera  
con particolare in Oro spazzolato.  
Vetri soffiati bianco latte.

Metal ceiling lamp.  
Licorice Black colour  
with brushed Gold detail.  
Milk-white blown glass.

Deckenleuchte aus Metall  
in Lakritzschwarz mit Details  
in gebürstetem Gold.  
Milchweißes mundgeblasenes Glas.

Plafonnier en métal,  
couleur Liquirizia Nera  
avec détails or brossé.  
Verre soufflé blanc laiteux.

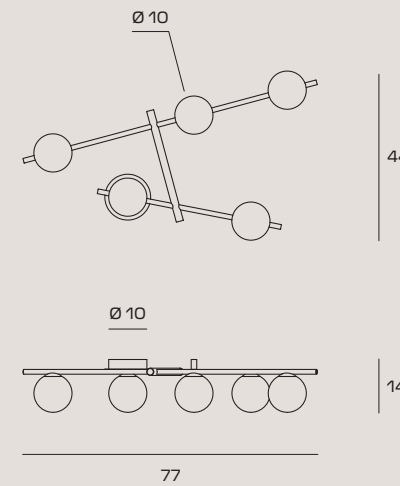
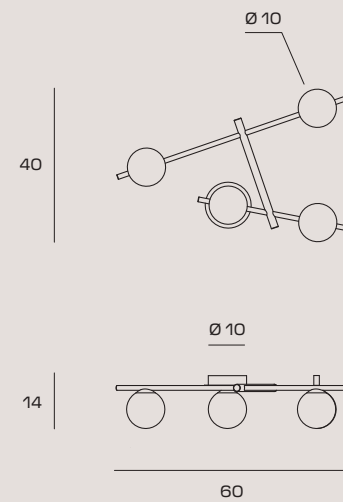

# KIKA

## CEILING LAMP

Lampada da soffitto in metallo,  
in colore Liquirizia Nera  
con particolare in Oro spazzolato.  
Vetri soffiati bianco latte.

Metal ceiling lamp.  
Licorice Black colour  
with brushed Gold detail.  
Milk-white blown glass.

Deckenleuchte aus Metall  
in Lakritzschwarz mit Details  
in gebürstetem Gold.  
Milchweißes mundgeblasenes Glas.

Plafonnier en métal,  
couleur Liquirizia Nera  
avec détails or brossé.  
Verre soufflé blanc laiteux.

CODE	1744.360
COLOR	● Black Licorice

### LIGHT SOURCE

Source G9 LED | Power 4 x max 10w  
Max bulb size: Ø20xH60mm



CODE	1744.361
COLOR	● Black Licorice

### LIGHT SOURCE

Source G9 LED | Power 5 x max 10w  
Max bulb size: Ø20xH60mm





# JUGEN

## JUGEN

Incantevole armonia.  
Jugen è l'esemplificazione perfetta dell'equilibrio: la sfera in vetro opalino, elemento diffusore per eccellenza, è sostenuta da una sottile asta in metallo in un gioco basato sul dialogo tra pesi, dove ogni elemento ha il suo esatto contraltare. Nella sua totalità Jugen risulta tanto semplice quanto espressiva: la doppia finitura oro e nero la caratterizza ulteriormente grazie alla relazione tra i due diversi materiali, la versione total black la rende discreta e facile da abbinare in molteplici realtà.

Enchanting harmony.  
Jugen is a perfect example of balance: the opal glass sphere - the lamp diffuser par excellence - is supported by a thin metal rod, in a game based on the dialogue between weights, where each element has its exact counterpart. In its entirety, Jugen is as simple as it is expressive: the double gold and black finish further characterises it, by relating two different materials, while the total black version makes it discreet and easy to combine in multiple contexts.

Bezaubernde Harmonie.  
Jugen ist die perfekte Verkörperung des Gleichgewichts: Die Opalglaskugel, das Diffusorelement schlechthin, wird von einem dünnen Metallstab in einem Spiel getragen, das auf einem Dialog zwischen den Gewichten beruht, bei dem jedes Element sein genaues Gegenstück hat. In ihrer Gesamtheit ist Jugen ebenso schlicht wie ausdrucksstark: Die doppelte Ausführung in Gold und Schwarz verleiht dank der Beziehung zwischen den beiden unterschiedlichen Materialien einen besonderen Charakter; die komplett schwarze Version macht sie diskret und lässt sich leicht in verschiedenen Umgebungen kombinieren.

Une délicieuse harmonie.  
Jugen exprime un équilibre parfait grâce à sa sphère en verre opalin, élément diffuseur par excellence, soutenu par une fine tige en métal, dans un jeu de dialogue des poids où chaque élément trouve sa contrepartie exacte. Dans son ensemble, Jugen est aussi simple qu'expressif : la double finition or et noire le caractérise encore davantage en créant une relation entre les deux matériaux. La version total black en fait un objet discret et s'adaptant aisément à de nombreuses réalités.

# JUGEN

SUSPENSION





# JUGEN

SUSPENSION



# JUGEN

SUSPENSION



# JUGEN

SUSPENSION



# JUGEN

TABLE LAMP





# JUGEN

WALL LAMP





# JUGEN

CEILING LAMP

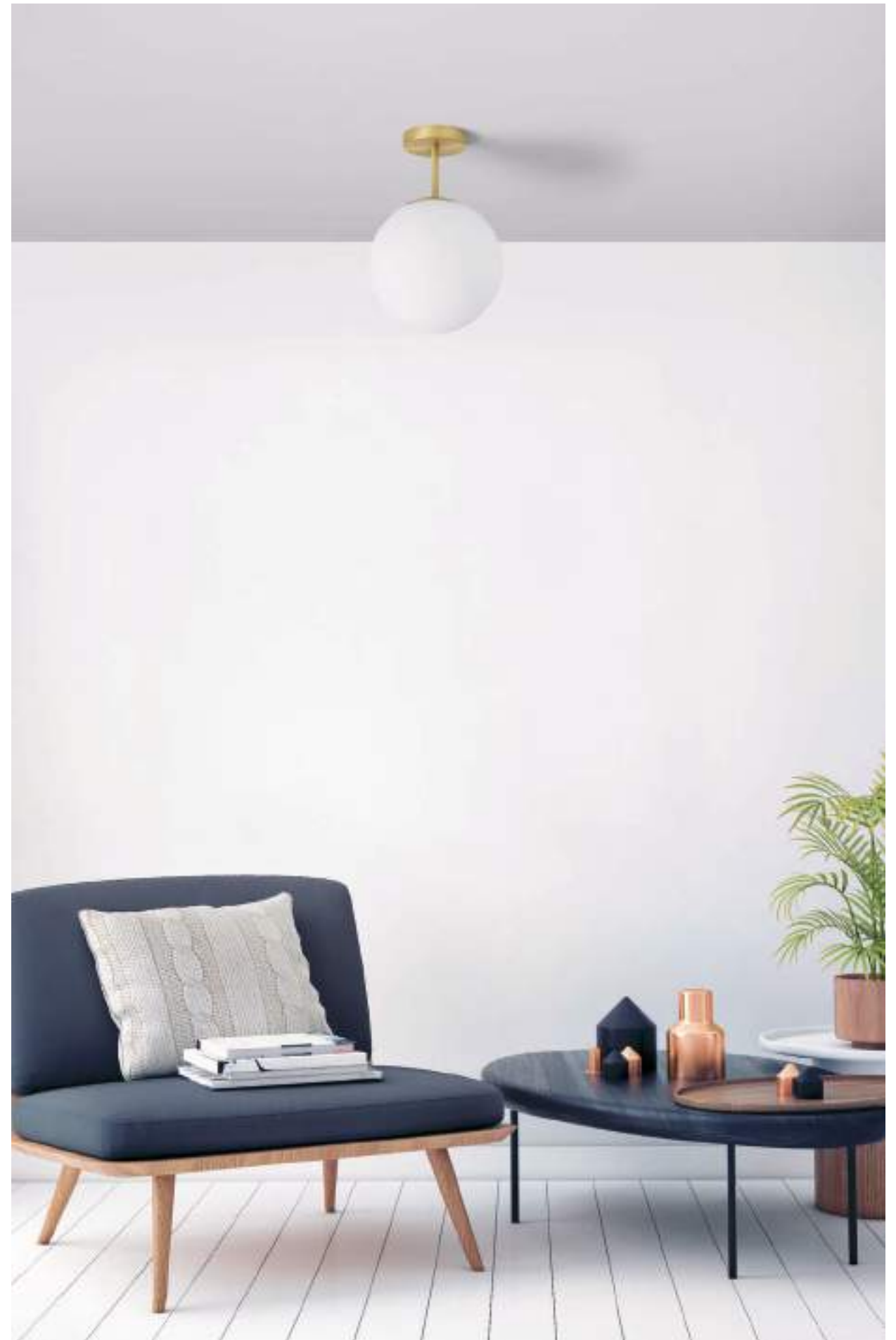



# JUGEN

CEILING LAMP



# JUGEN

CEILING LAMP

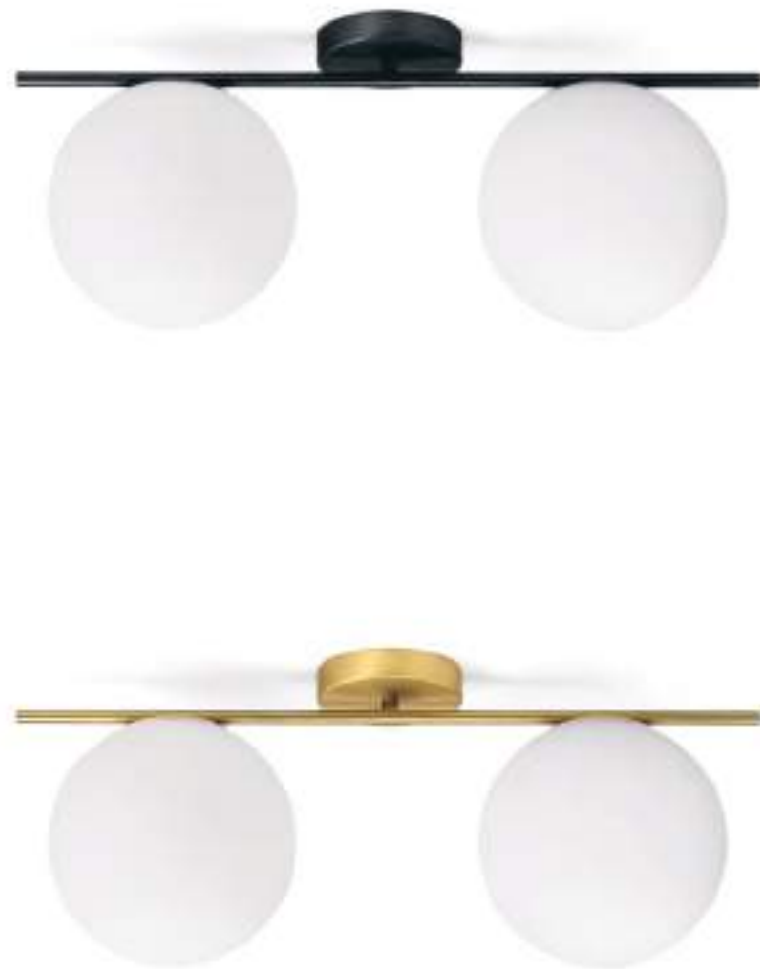

# JUGEN

FLOOR LAMP



# JUGEN

FLOOR LAMP





# JUGEN

FLOOR LAMP





# JUGEN

## SUSPENSION

Lampada a sospensione a 1 luce  
in vetro bianco latte.  
Montatura oro spazzolato  
e montatura verniciata nera.  
Cavo di alimentazione 200 cm.

Suspension lamp with 1 light  
in milky white glass.  
Frame in brushed gold  
and black painted frame.  
200 cm power cable.

1-flammige Pendelleuchte  
aus milchweißem Glas.  
Fassung aus gebürstetem Gold  
und schwarz lackierte Fassung.  
200 cm Stromkabel.

Suspension à 1 lumière  
en verre blanc lait.  
Structure en or brossé  
et Structure laquée noire.  
Câble d'alimentation de 200 cm.

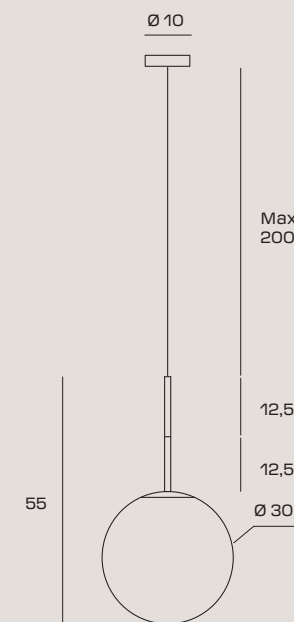

CODE	1744.70	1744.205
COLOR	● Brushed Gold	● Black

### LIGHT SOURCE

Source E27 LED | Power 1 x max 20w  
Max bulb size: Ø65xH240mm



# JUGEN

## SUSPENSION

Lampada a sospensione a 2 luci in vetro bianco latte. Montatura oro spazzolato e montatura verniciata nera. Possibilità di utilizzare prolunghe da 40 cm e 50 cm.

Suspension lamp with 2 lights in milky white glass. Frame in brushed gold and black painted frame. Possibility of using the 40 cm and 50 cm rods.

2-flammige Pendelleuchte aus milchweißem Glas. Fassung aus gebürstetem Gold und schwarz lackierte Fassung. Nutzung der cm 40 und cm 50 Röhren möglich.

Suspension à 2 lumières en verre blanc lait. Structure en or brossé et Structure laquée noire. Possibilité d'utiliser les tiges de 40 cm et 50 cm.

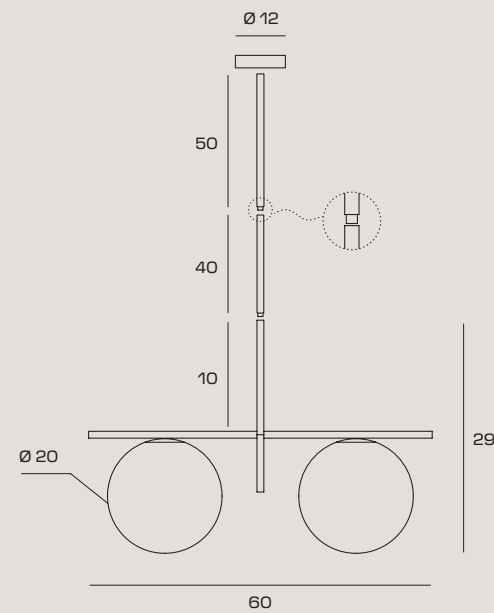

CODE	1744.64	1744.200
COLOR	● Brushed Gold	● Black

### LIGHT SOURCE

Source E27 LED | Power 2 x max 20w  
Max bulb size: Ø50xH140mm



# JUGEN

## SUSPENSION

Lampada a sospensione a 4 luci in vetro bianco latte. Montatura oro spazzolato e montatura verniciata nera. Possibilità di utilizzare prolunghe da 40cm e 50 cm.

Suspension lamp with 4 lights in milky white glass. Frame in brushed gold and black painted frame. Possibility of using the 40 cm and 50 cm rods.

4-flammige Hängeleuchte aus milchweißem Glas mit Fassung aus gebürstetem Gold und schwarz lackierte Fassung. Nutzung der cm 40 und cm 50 Röhren möglich.

Suspension à 4 lumières en verre blanc lait. Structure en or brossé et Structure laquée noire. Possibilité d'utiliser les tiges de 40cm et 50cm.

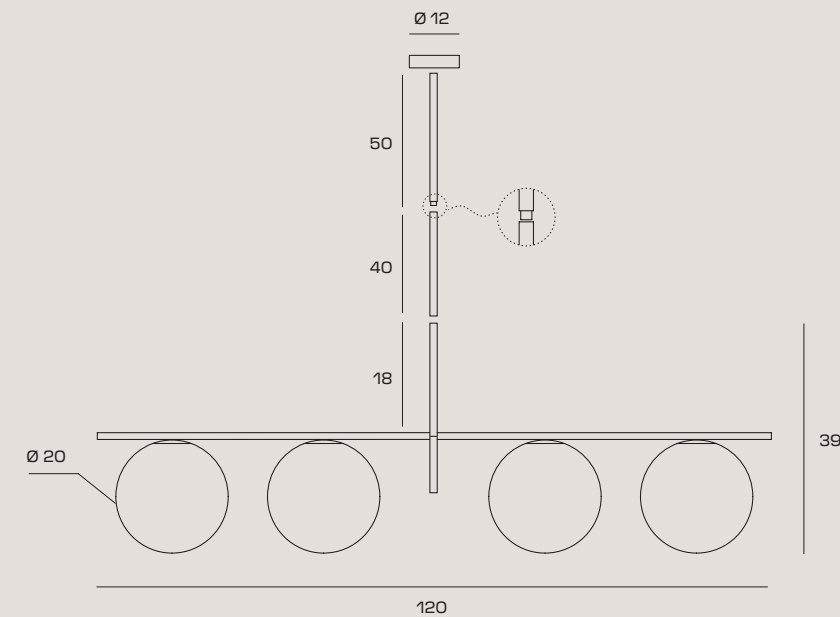

CODE	1744.68	1744.204
COLOR	● Brushed Gold	● Black

### LIGHT SOURCE

Source E27 LED | Power 4 x max 20w  
Max bulb size: Ø50xH140mm



# JUGEN

## TABLE

Lampada da tavolo a 1 luce  
in vetro bianco latte.  
Montatura oro spazzolato  
e montatura verniciata nera.

Table lamp with 1 light  
in milky white glass.  
Frame in brushed gold  
and black painted frame.

1-flammige Tischleuchte  
aus milchweißem Glas.  
Fassung aus gebürstetem Gold  
und schwarz lackierte Fassung.

Lampe à poser à 1 lumière  
en verre blanc lait.  
Structure en or brossé  
et Structure laquée noire.

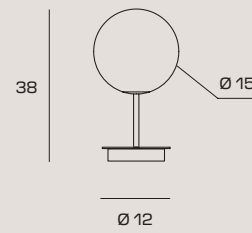

CODE	1744.63	1744.199
COLOR	● Brushed Gold	● Black

### LIGHT SOURCE

Source E27 LED DIMMABLE | Power 1 x max 20w  
Max bulb size: Ø50xH90mm



# JUGEN

## WALL LAMP

Lampada da parete a 1 luce  
in vetro bianco latte.  
Montatura oro spazzolato  
e montatura verniciata nera.

Wall lamp with 1 light  
in milky white glass.  
Frame in brushed gold  
and black painted frame.

1-flammige Wandleuchte  
aus milchweißem Glas.  
Fassung aus gebürstetem Gold  
und schwarz lackierte Fassung.

Applique à 1 lumière  
en verre blanc lait.  
Structure en or brossé  
et Structure laquée noire.

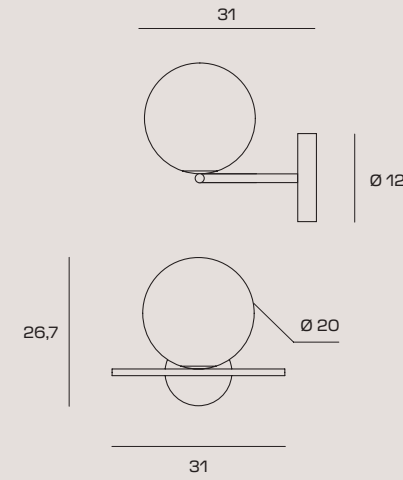

CODE	1744.72	1744.207
COLOR	● Brushed Gold	● Black

### LIGHT SOURCE

Source E27 LED | Power 1 x max 20w  
Max bulb size: Ø50xH140mm

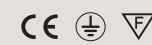

# JUGEN

## WALL LAMP

Lampada da parete a 2 luci  
in vetro bianco latte.  
Montatura oro spazzolato  
e montatura verniciata nera.

Wall lamp with 2 lights  
in milky white glass.  
Frame in brushed gold  
and black painted frame.

2-flammige Wandleuchte  
aus milchweißem Glas.  
Fassung aus gebürstetem Gold  
und schwarz lackierte Fassung.

Applique à 2 lumière  
en verre blanc lait.  
Structure en or brossé  
et Structure laquée noire.

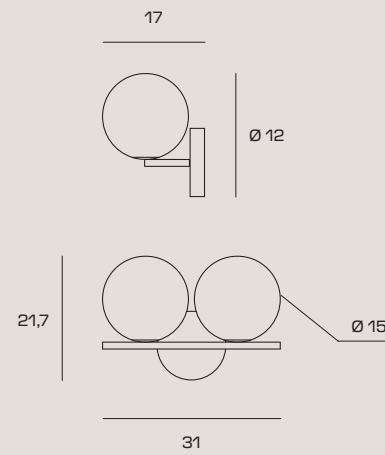

CODE	1744.73	1744.208
COLOR	● Brushed Gold	● Black

### LIGHT SOURCE

Source E27 LED | Power 2 x max 20w  
Max bulb size: Ø50xH90mm



# JUGEN

## CEILING LAMP

Lampada da soffitto a 1 luce  
in vetro bianco latte.  
Montatura oro spazzolato  
e montatura verniciata nera.

Ceiling lamp with 1 light  
in milky white glass.  
Frame in brushed gold  
and black painted frame.

1-flammige Deckenleuchte  
aus milchweißem Glas.  
Fassung aus gebürstetem Gold  
und schwarz lackierte Fassung.

Plafonnier à 1 lumière  
en verre blanc lait.  
Structure en or brossé  
et Structure laquée noire.

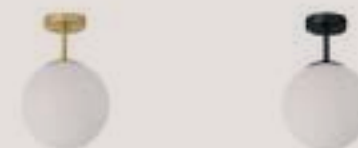
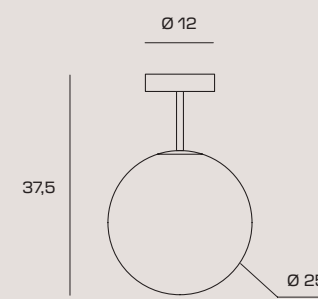

CODE	1744.66	1744.202
COLOR	● Brushed Gold	● Black

### LIGHT SOURCE

Source E27 LED | Power 1 x max 20w  
Max bulb size: Ø50xH140mm



# JUGEN

## CEILING LAMP

Lampada da soffitto a 2 luci  
in vetro bianco latte.  
Montatura oro spazzolato  
e montatura verniciata nera.

Ceiling lamp with 2 lights  
in milky white glass.  
Frame in brushed gold  
and black painted frame.

2-flammige Deckenleuchte  
aus milchweißem Glas.  
Fassung aus gebürstetem Gold  
und schwarz lackierte Fassung.

Plafonnier à 2 lumières  
en verre blanc lait.  
Structure en or brossé  
et Structure laquée noire.

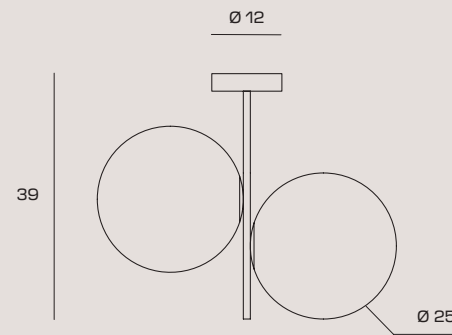

CODE	1744.67	1744.203
COLOR	● Brushed Gold	● Black

### LIGHT SOURCE

Source E27 LED | Power 2 x max 20w  
Max bulb size: Ø65xH190mm



# JUGEN

## CEILING LAMP

Lampada da soffitto a 2 luci  
in vetro bianco latte.  
Montatura oro spazzolato  
e montatura verniciata nera.

Ceiling lamp with 2 lights  
in milky white glass.  
Frame in brushed gold  
and black painted frame.

2-flammige Deckenleuchte  
aus milchweißem Glas.  
Fassung aus gebürstetem Gold  
und schwarz lackierte Fassung.

Plafonnier à 2 lumières  
en verre blanc lait.  
Structure en or brossé  
et Structure laquée noire.

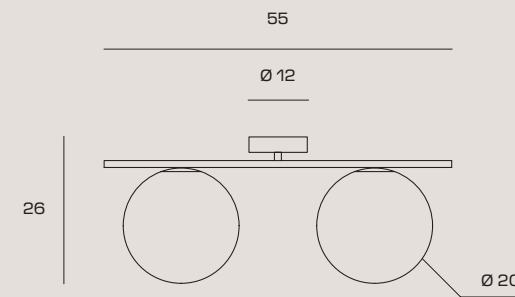

CODE	1744.65	1744.201
COLOR	● Brushed Gold	● Black

### LIGHT SOURCE

Source E27 LED | Power 2 x max 20w  
Max bulb size: Ø50xH140mm



# JUGEN

## FLOOR LAMP

Lampada da terra a 1 luce  
in vetro bianco latte.  
Montatura oro spazzolato  
e montatura verniciata nera.  
Dotata di dimmer a piede.

Floor lamp with 1 light  
in milky white glass.  
Frame in brushed gold  
and black painted frame.  
Equipped with foot dimmer.

1-flammige Stehleuchte  
aus milchweißem Glas.  
Fassung aus gebürstetem Gold  
und schwarz lackierte Fassung.  
Ausgestattet mit Fußdimmer.

Lampadaire à 1 lumière  
en verre blanc lait.  
Structure en or brossé  
et Structure laquée noire.  
Équipé d'un variateur  
de lumière au pied.

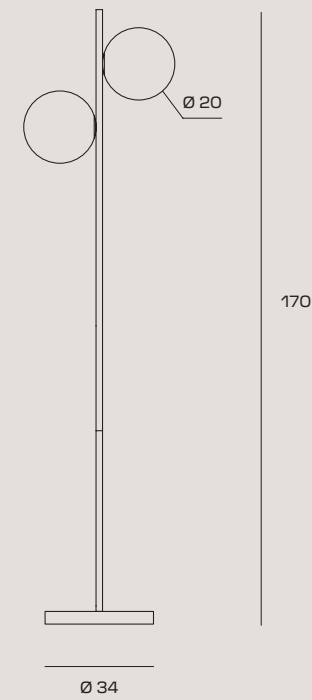
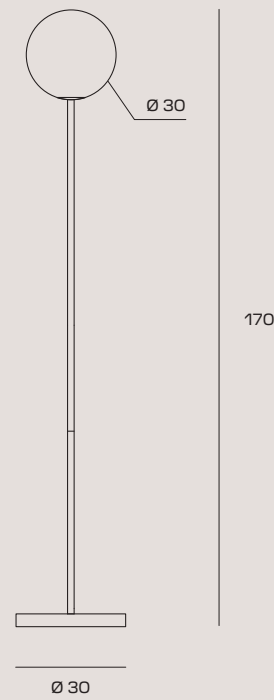

CODE	1744.62	1744.198
COLOR	● Brushed Gold	● Black

### LIGHT SOURCE

Source E27 LED DIMMABLE | Power 2 x max 30w  
Max bulb size: Ø65xH240mm



# JUGEN

## FLOOR LAMP

Lampada da terra a 2 luci  
in vetro bianco latte.  
Montatura oro spazzolato  
e montatura verniciata nera.  
Dotata di dimmer a piede.

Floor lamp with 2 lights  
in milky white glass.  
Frame in brushed gold  
and black painted frame.  
Equipped with foot dimmer.

2-flammige Stehleuchte  
aus milchweißem Glas.  
Fassung aus gebürstetem Gold  
und schwarz lackierte Fassung.  
Ausgestattet mit Fußdimmer.

Lampadaire à 2 lumières  
en verre blanc lait.  
Structure en or brossé  
et Structure laquée noire.  
Équipé d'un variateur  
de lumière au pied.



CODE	1744.71	1744.206
COLOR	● Brushed Gold	● Black

### LIGHT SOURCE

Source E27 LED DIMMABLE | Power 2 x max 30w  
Max bulb size: Ø50xH140mm





## LINGOTTO

Il rigore fatto lampada.  
La struttura ortogonale di Lingotto conferisce severità alla composizione, le finiture in oro spazzolato e oro rosa degli elementi tridimensionali ne elevano la preziosità, il vetro opalino dalla forma squadrata, a custodia dei punti luce, ne amplifica la linearità.  
Lingotto, con la sua sola presenza, arricchisce ogni contesto in cui è inserito, come un'opera d'arte dal valore inestimabile.

Precision in a lamp.  
Lingotto's orthogonal structure makes the layout stern, while the brushed gold and rose gold finishes on 3D elements elevate its preciousness, and the square-shaped opaline glass housing the light fixtures amplifies its linearity.  
With its presence alone, Lingotto embellishes any context in which it is included, as a work of art of inestimable value.

Die Strenge in Gestalt einer Lampe.  
Die orthogonale Struktur von Lingotto verleiht der Komposition Strenge, die Oberflächen der dreidimensionalen Elemente aus gebürstetem Gold und Roségold unterstreichen ihre Kostbarkeit, und das quadratische Opalglas, in dem die Lichtpunkte untergebracht sind, verstärkt ihre Linearität.  
Lingotto bereichert durch ihre bloße Anwesenheit jeden Kontext, in den sie gestellt wird, wie ein unbezahlbares Kunstwerk.

La rigueur faite lampe.  
La structure orthogonale de Lingotto confère de la sévérité à la composition, les finitions brossées or et or rose des éléments tridimensionnels soulignent sa dimension précieuse, et le verre opalin carré renferme les points lumineux en amplifiant leur linéarité.  
La seule présence de Lingotto raffine tous les contextes, à la manière d'une œuvre d'art à la valeur inestimable.

# LINGOTTO

SUSPENSION





# LINGOTTO

TABLE





# LINGOTTO

WALL LAMP





# LINGOTTO

WALL LAMP





# LINGOTTO

FLOOR LAMP



# LINGOTTO

## SUSPENSION

Lampada sospensione in metallo nero, con particolari oro spazzolato e oro rosa. Vetri soffiati opalino forma arrotondata.

Black metal pendant lamp, with brushed gold and rose gold details. Rounded opal blown glass.

Hängeleuchte aus schwarzem Metall mit Details aus gebürstetem Gold und Roségold. Opalines geblasenes Glas, runde Form.

Suspension en métal noir avec détails brossés or et or rose. Verre soufflé opalin rond.

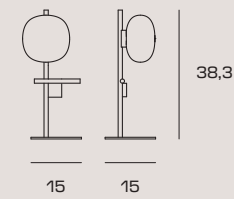
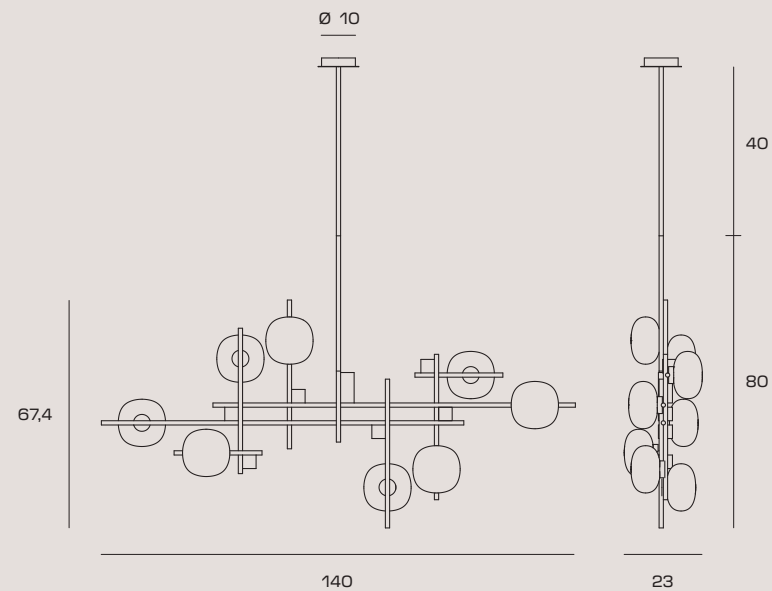

# LINGOTTO

## TABLE

Lampada da tavolo in metallo nero, con particolari oro spazzolato e oro rosa. Vetri soffiati opalino forma arrotondata. Dotata di dimmer.

Black metal table lamp, with brushed gold and rose gold details. Rounded opal blown glass. Dimmerable.

Tischleuchte aus schwarzem Metall mit Details aus gebürstetem Gold und Roségold. Opalines geblasenes Glas, runde Form. Ausgestattet mit Dimmer.

Lampe de table en métal noir avec détails brossés or et or rose. Verre soufflé opalin rond. Avec variateur.

CODE	1744.351
COLOR	● Black

### LIGHT SOURCE

Source G9 LED | Power 8 x max 10w  
Max bulb size: Ø20xH60mm



CODE	1744.349
COLOR	● Black

### LIGHT SOURCE

Source G9 LED DIMMABLE | Power 1 x max 10w  
Max bulb size: Ø20xH60mm



# LINGOTTO

## TABLE

Lampada da tavolo in metallo nero, con particolari oro spazzolato e oro rosa. Vetri soffiati opalino forma arrotondata. Dotata di dimmer.

Black metal table lamp, with brushed gold and rose gold details. Rounded opal blown glass. Dimmerable.

Tischleuchte aus schwarzem Metall mit Details aus gebürstetem Gold und Roségold. Opalines geblasenes Glas, runde Form. Ausgestattet mit Dimmer.

Lampe de table en métal noir avec détails brossés or et or rose. Verre soufflé opalin rond. Avec variateur.

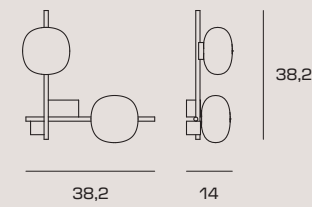
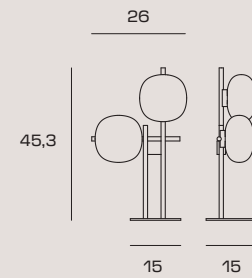

# LINGOTTO

## WALL LAMP

Lampada a parete in metallo nero, con particolari oro spazzolato e oro rosa. Vetri soffiati opalino forma arrotondata.

Black metal wall lamp, with brushed gold and rose gold details. Rounded opal blown glass.

Wandleuchte aus schwarzem Metall mit Details aus gebürstetem Gold und Roségold. Opalines geblasenes Glas, runde Form.

Applique en métal noir avec détails brossés or et or rose. Verre soufflé opalin rond.

CODE	1744.350
COLOR	● Black

### LIGHT SOURCE

Source G9 LED DIMMABLE | Power 2 x max 10w  
Max bulb size: Ø20xH60mm



CODE	1744.344
COLOR	● Black

### LIGHT SOURCE

Source G9 LED | Power 2 x max 10w  
Max bulb size: Ø20xH60mm



# LINGOTTO

## WALL LAMP

Lampada a parete in metallo nero, con particolari oro spazzolato e oro rosa. Vetri soffiati opalino forma arrotondata.

Black metal wall lamp, with brushed gold and rose gold details. Rounded opal blown glass.

Wandleuchte aus schwarzem Metall mit Details aus gebürstetem Gold und Roségold. Opalines geblasenes Glas, runde Form.

Applique en métal noir avec détails brossés or et or rose. Verre soufflé opalin rond.

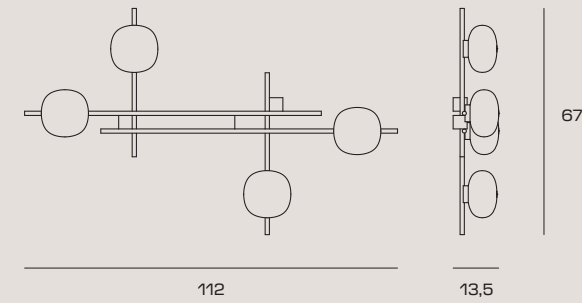
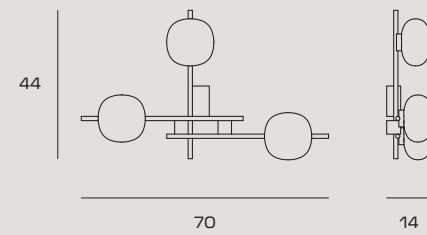

# LINGOTTO

## WALL LAMP

Lampada a parete in metallo nero, con particolari oro spazzolato e oro rosa. Vetri soffiati opalino forma arrotondata.

Black metal wall lamp, with brushed gold and rose gold details. Rounded opal blown glass.

Wandleuchte aus schwarzem Metall mit Details aus gebürstetem Gold und Roségold. Opalines geblasenes Glas, runde Form.

Applique en métal noir avec détails brossés or et or rose. Verre soufflé opalin rond.

CODE 1744.346

COLOR ● Black

### LIGHT SOURCE



Source G9 LED | Power 3 x max 10w  
Max bulb size: Ø20xH60mm



CODE 1744.347

COLOR ● Black

### LIGHT SOURCE



Source G9 LED | Power 4 x max 10w  
Max bulb size: Ø20xH60mm

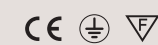

# LINGOTTO

## CEILING LAMP

Lampada a soffitto in metallo nero, con particolari oro spazzolato e oro rosa. Vetri soffiati opalino forma arrotondata.

Black metal ceiling lamp, with brushed gold and rose gold details. Rounded opal blown glass.

Deckenleuchte aus schwarzem Metall mit Details aus gebürstetem Gold und Roségold. Opalines geblasenes Glas, runde Form. Die Lampe ist mit einem Dimmer ausgestattet.

Suspension en métal noir avec détails brossés or et or rose. Verre soufflé opalin rond. Lampe équipée d'un variateur.

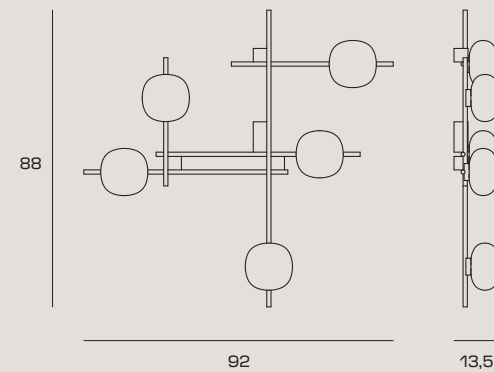

# LINGOTTO

## FLOOR LAMP

Lampada da terra in metallo nero, con particolari oro spazzolato e oro rosa. Vetri soffiati opalino forma arrotondata. Lampada dotata di Dimmer.

Black metal floor lamp, with brushed gold and rose gold details. Rounded opal blown glass. Dimmerable.

Stehleuchte aus schwarzem Metall mit Details aus gebürstetem Gold und Roségold. Opalines geblasenes Glas, runde Form. Die Lampe ist mit einem Dimmer ausgestattet.

Lampe en métal noir avec détails brossés or et or rose. Verre soufflé opalin rond. Lampe équipée d'un variateur.

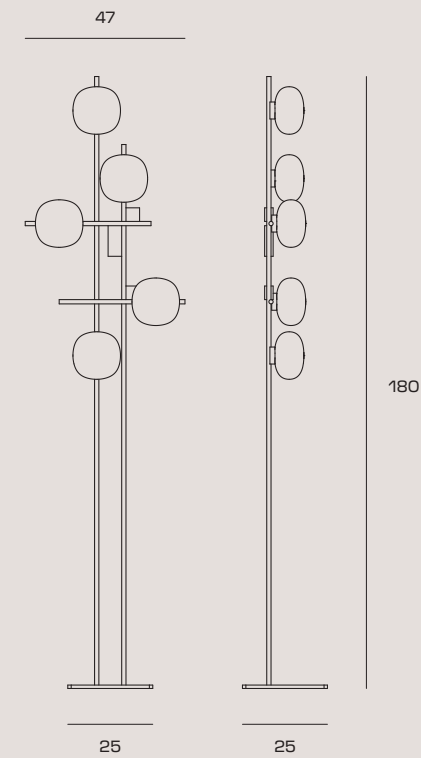

CODE	1744.348
COLOR	● Black

### LIGHT SOURCE

Source G9 LED | Power 5 x max 10w  
Max bulb size: Ø20xH60mm



CODE	1744.345
COLOR	● Black

### LIGHT SOURCE

Source G9 LED DIMMABLE | Power 5 x max 10w  
Max bulb size: Ø20xH60mm



# POMÌ

## POMÌ

Il fascino della caducità. Le sfere in vetro opalino di Pomì, posizionate in maniera dinamica nello spazio, paiono sospese nel vuoto: solo una sottile base le tiene ancorate all'asta in metallo. Un'apparente stasi temporale che genera una composizione tanto libera quanto equilibrata, grazie alla quale Pomì trova inserimento in molteplici contesti. La variante in ottone spazzolato conferisce preziosità, quella in metallo nero con dettagli in ottone ha un'elegante sobrietà.

The allure of transience. Pomì opaline glass spheres, arranged dynamically in space, appear to be suspended in air: a thin base is the only thing keeping them anchored to the metal rod. An apparent temporal stasis that generates a composition as free as it is balanced, through which Pomì finds its place in multiple contexts. The brushed brass variant makes everything precious, while the black metal version with brass details is elegantly understated.

Die Verlockung der Vergänglichkeit. Die Opalglaskugeln von Pomì, die dynamisch im Raum positioniert sind, scheinen in der Leere zu schweben: nur ein dünner Sockel hält sie an der Metallstange verankert. Ein scheinbarer zeitlicher Stillstand, der eine ebenso freie wie ausgewogene Komposition hervorbringt, dank derer Pomì ihren Platz in verschiedenen Kontexten findet. Die Variante aus gebürstetem Messing wirkt edel, die schwarze Metallvariante mit Messingdetails hat ein elegantes Understatement.

La séduction de l'éphémère. Les sphères en verre opalin de Pomì, placées dynamiquement dans l'espace, semblent suspendues dans le vide, uniquement rattachées à la tige en métal par une base très fine. Une apparente stase temporelle, aboutissant à une composition aussi libre qu'équilibrée et qui permet à Pomì de s'insérer dans de nombreux contextes. La variante en laiton brossé est particulièrement raffinée, tandis que celle en métal noir avec détails en laiton offre une sobriété pleine d'élégance.

# POMÌ

SUSPENSION



# POMÌ

TABLE



# POMÌ

WALL LAMP



# POMÌ

FLOOR LAMP



# POMÌ

## FLOOR LAMP

Lampada da terra a 5 luci  
in vetro bianco latte.  
Montatura verniciata nero con particolare  
in ottone spazzolato (1744.101)  
o montatura oro spazzolato (1744.270).

5-light ground lamp  
made of milk white glass.  
Black painted support with  
brushed brass detail (1744.101)  
or brushed gold support (1744.270).

Bodenleuchte mit 5 Lichtern  
aus milchweißem Glas.  
Schwarz lackiertes Gestell  
mit gebürsteten Messingdetails (1744.101)  
oder goldfarbenes gebürstetes Gestell (1744.270).

Lampadaire 5 points lumineux  
en verre blanc laiteux.  
Monture peinte en noir avec détails  
en laiton brossé (1744.101)  
ou monture or brossé (1744.270).

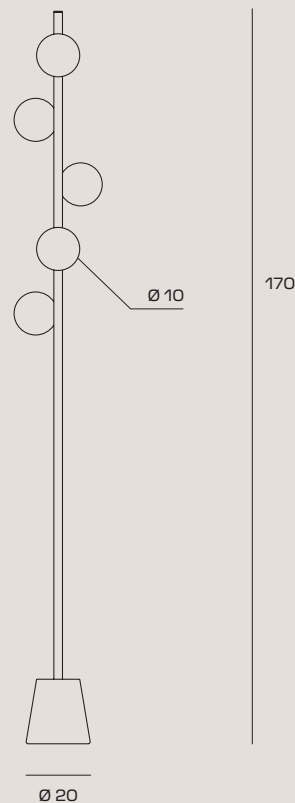

CODE	1744.101	1744.270
COLOR	● Black	● Brushed Gold

### LIGHT SOURCE

 G9 LED DIMMABLE | 5 x max 10w  
Max bulb size: Ø20xH60mm



# POMÌ

## SUSPENSION

Lampada a sospensione a 7 luci  
in vetro bianco latte.  
Montatura verniciata nero con particolari  
in ottone spazzolato (1744.98)  
o montatura oro spazzolato (1744.269).  
Cavo di alimentazione 200 cm.

7-light suspension lamp  
made of milk white glass.  
Black painted support with  
brushed brass details (1744.98)  
or brushed gold support (1744.269).  
200 cm power supply cord.

Hängeleuchte mit 7 Lichtern  
aus milchweißem Glas.  
Schwarz lackiertes Gestell mit  
gebürsteten Messingdetails (1744.98)  
oder goldfarbenes gebürstetes  
Gestell (1744.269).  
Schwarzes Stromkabel 200 cm.

Suspension à 7 points lumineux  
en verre blanc laiteux.  
Monture peinte en noir avec détails  
en laiton brossé (1744.98)  
ou monture or brossé (1744.269).  
Câble d'alimentation de 200 cm.

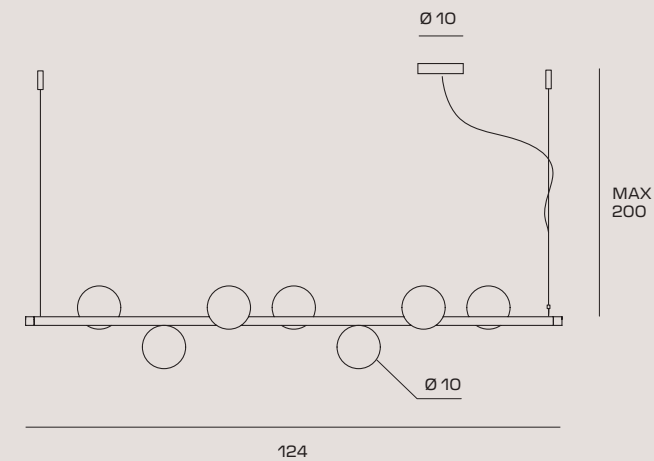

CODE	1744.98	1744.269
COLOR	● Black	● Brushed Gold

### LIGHT SOURCE

 G9 LED | 7 x max 10w  
Max bulb size: Ø20xH60mm



# POMÌ

## TABLE

Lampada da tavolo a 1 luce  
in vetro bianco latte.  
Montatura verniciata nero con particolare  
in ottone spazzolato (1744.105),  
o montatura oro spazzolato (1744.272).

1-light table lamp  
made of milk white glass.  
Black painted support with  
brushed brass details (1744.105)  
or brushed gold support (1744.272).

Tischleuchte mit 1 Licht  
aus milchweißem Glas.  
Schwarz lackiertes Gestell mit gebürsteten  
Messingdetails (1744.105) oder goldfarbenes  
gebürstetes Gestell (1744.272).

Lampe de table 1 point lumineux  
en verre blanc laiteux.  
Monture peinte en noir avec détails  
en laiton brossé (1744.105)  
ou monture or brossé (1744.272).

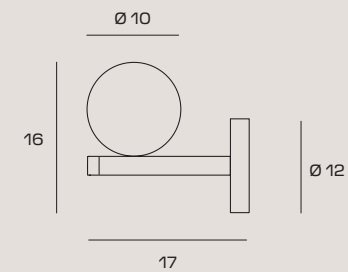
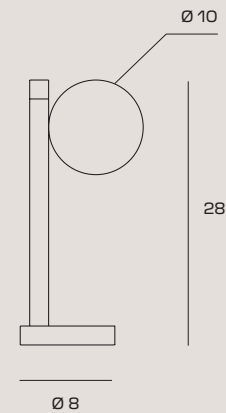

# POMÌ

## WALL LAMP

Lampada da parete a 1 luce  
in vetro bianco latte.  
Montatura verniciata nero con particolare  
in ottone spazzolato (1744.104),  
o montatura oro spazzolato (1744.271).

1-light wall lamp  
made of milk white glass.  
Black painted support with  
brushed brass detail (1744.104)  
or brushed gold support (1744.271).

Wandleuchte mit 1 Licht  
aus milchweißem Glas.  
Schwarz lackiertes Gestell mit gebürsteten  
Messingdetails (1744.104) oder goldfarbenes  
gebürstetes Gestell (1744.271).

Applique 1 point lumineux  
en verre blanc laiteux.  
Monture peinte en noir avec détails  
en laiton brossé (1744.104)  
ou monture or brossé (1744.271).



CODE	1744.105	1744.272
COLOR	● Black	● Brushed Gold

### LIGHT SOURCE

G9 LED DIMMABLE | 1 x max 10w  
Max bulb size: Ø20xH60mm

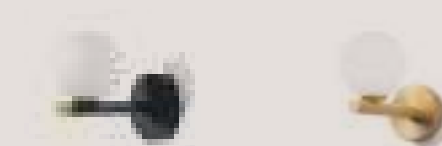

CODE	1744.104	1744.271
COLOR	● Black	● Brushed Gold

### LIGHT SOURCE

G9 LED | 1 x max 10w  
Max bulb size: Ø20xH60mm





# BUBLE

## **BUBLE**

Una cornice con vista sulla dinamicità della vita. In Buble severità e vivacità convivono: la cornice, rigida e squadrata, contiene e sorregge una serie di bolle in vetro opalino, caratterizzate da molteplici dimensioni e posizioni. L'asimmetria dei punti luce scandisce lo spazio, la proporzione tra questi restituisce equilibrio, l'insieme rende Buble affascinante e senza tempo.

A frame with a view onto our dynamic lifestyles. toughness and liveliness coexist, with the stiff and squared frame containing and supporting a series of opal glass bubbles, in multiple sizes and positions. The asymmetric lights articulate the space, with their proportions giving it balance, and the assembly making Buble fascinating and timeless.

Ein rahmen mit blick auf die dynamik des lebens. in Buble bestehen strenge und lebendigkeit nebeneinander: der starre und rechteckige rahmen enthält und stützt eine reihe von blasen aus opalglas, geprägt durch vielfältige abmessungen und positionen. Die asymmetrie der lichtquellen unterteilt den raum, die proportionen zwischen ihnen sorgt für gleichgewicht, die gesamtheit macht Buble faszinierend und zeitlos.

Un cadre avec vue sur le dynamisme de la vie. La sévérité et la vivacité cohabitent dans Buble : le cadre, rigide et carré, contient et supporte une série de bulles en verre opalin, caractérisées par de multiples dimensions et positions. L'asymétrie des points lumineux ponctue l'espace, et leur proportion rétablit l'équilibre ; l'ensemble rend Buble fascinant et intemporel.

# BUBBLE

SUSPENSION





# BUBBLE

SUSPENSION



# BUBBLE

SUSPENSION



# BUBBLE

TABLE







# BUBBLE

TABLE



# BUBBLE

WALL LAMP



# BUBBLE

WALL LAMP



# BUBBLE

CEILING





# BUBBLE

FLOOR LAMP



# BUBBLE

## SUSPENSION

Lampada a sospensione  
con 3 luci in oro spazzolato  
o acciaio spazzolato.  
Vetri sfera soffiati colore opalino.

Pendant lamp with 3 lights  
in brushed gold or brushed steel.  
Opaline blown sphere glass.

Pendelleuchte 3 Lichter in gebürstetem  
Gold oder gebürstetem Stahl.  
Geblasenes Kugelglas in Opalfarbe

Suspension à 3 points lumineux,  
or brossé ou acier.  
Sphère en verre soufflé  
couleur opaline

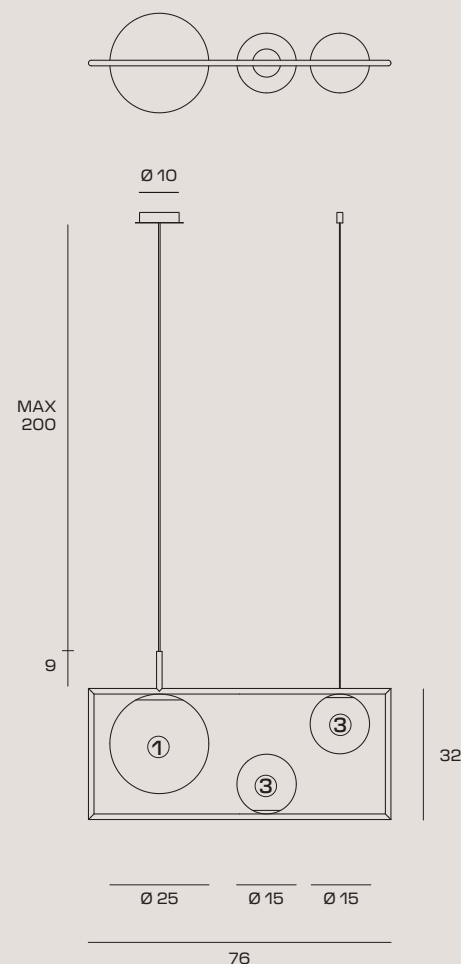

CODE	1744.318	1744.363
COLOR	● Brushed Gold	● Brushed Steel

### LIGHT SOURCE

Source E27 LED | Power 3 x max 20w  
Max bulb size: ①: Ø65xH190mm  
③: Ø50xH90mm



# BUBBLE

## SUSPENSION

Lampada a sospensione  
con 5 luci in oro spazzolato  
o acciaio spazzolato.  
Vetri sfera soffiati colore opalino.

Pendant lamp  
with 5 lights in brushed gold  
or brushed steel.  
Opaline blown sphere glass.

Pendelleuchte 5 Lichter in gebürstetem  
Gold oder gebürstetem Stahl.  
Opalfarbenes geblasenes Kugelglas.

Suspension à 5 points lumineux,  
or brossé ou acier.  
Sphère en verre soufflé  
couleur opaline.

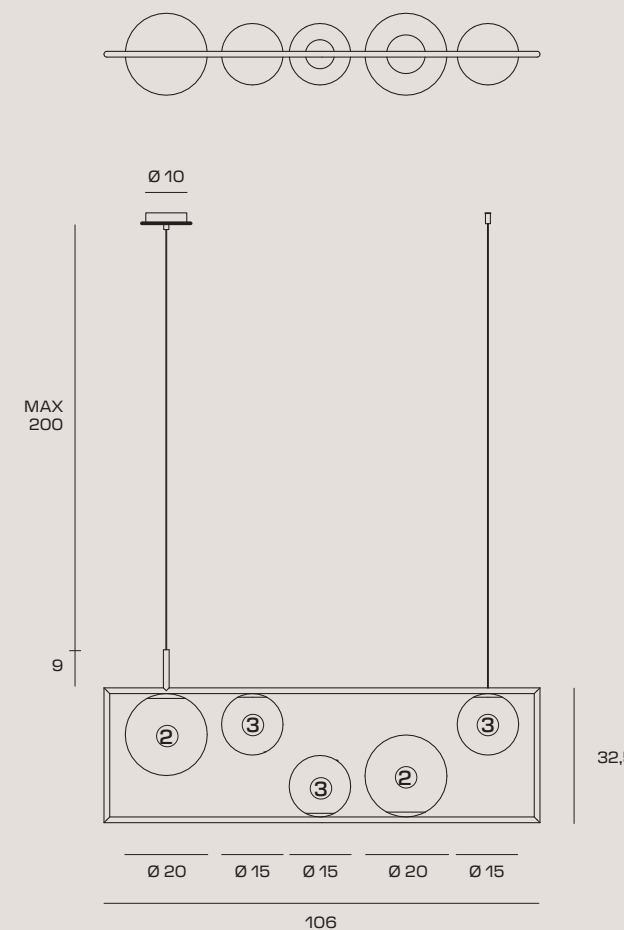

CODE	1744.343	1744.371
COLOR	● Brushed Gold	● Brushed Steel

### LIGHT SOURCE

Source E27 LED | Power 5 x max 20w  
Max bulb size: ②: Ø50xH140mm  
③: Ø50xH90mm



# BUBBLE

## TABLE

Lampada da tavolo 2 luci  
in oro spazzolato o acciaio spazzolato  
e particolare in bronzo.  
Vetri sfera soffiati colore opalino.  
Lampada dotata di Dimmer.

2-light table lamp,  
in brushed gold or brushed steel  
and bronze detail.  
Opaline blown sphere glass.  
Dimmerable.

Tischleuchte 2 Lichter  
aus gebürstetem Gold oder  
gebürstetem Stahl mit Bronzedetails.  
Opalfarbenes geblasenes Kugelglas.  
Die Lampe ist mit einem Dimmer  
ausgestattet.

Lampe de table 2 points lumineux  
or brossé ou acier brossé  
et détails en bronze.  
Sphère en verre soufflé couleur opaline.  
Lampe équipée d'un variateur.

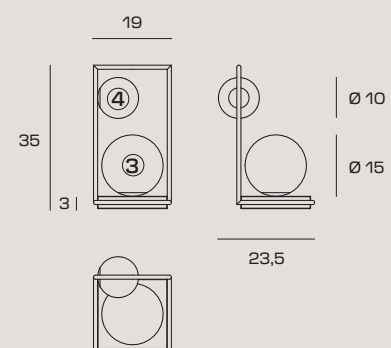
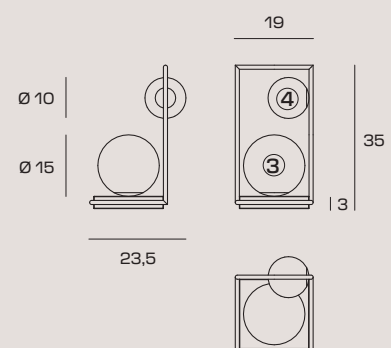

# BUBBLE

## TABLE

Lampada da tavolo 2 luci  
in oro spazzolato o acciaio spazzolato  
e particolare in bronzo.  
Vetri sfera soffiati colore opalino.  
Lampada dotata di Dimmer.

2-light table lamp,  
in brushed gold or brushed steel  
and bronze detail.  
Opaline blown sphere glass.  
Dimmerable.

Tischleuchte 2 Lichter  
aus gebürstetem Gold oder  
gebürstetem Stahl mit Bronzedetails.  
Opalfarbenes geblasenes Kugelglas.  
Die Lampe ist mit einem Dimmer  
ausgestattet.

Lampe de table 2 points lumineux  
or brossé ou acier brossé  
et détails en bronze.  
Sphère en verre soufflé couleur opaline.  
Lampe équipée d'un variateur.



CODE	1744.339	1744.367
COLOR	● Brushed Gold	● Brushed Steel

### LIGHT SOURCE

Source G9 LED DIMMABLE | Power 2 x max 10w  
Max bulb size: ③ : Ø50xH90mm  
④ : Ø20xH60mm



CODE	1744.340	1744.368
COLOR	● Brushed Gold	● Brushed Steel

### LIGHT SOURCE

Source G9 LED DIMMABLE | Power 2 x max 10w  
Max bulb size: ③ : Ø50xH90mm  
④ : Ø20xH60mm



# BUBBLE

## TABLE

Lampada da tavolo 4 luci  
in oro spazzolato o acciaio spazzolato  
e particolare in bronzo.  
Vetri sfera soffiati colore opalino.  
Lampada dotata di Dimmer.

4-light table lamp,  
in brushed gold or brushed steel  
and bronze detail.  
Opaline blown sphere glass.  
Dimmerable.

Tischleuchte 4 Lichter  
aus gebürstetem Gold oder  
gebürstetem Stahl mit Bronzedetails.  
Opalfarbenes geblasenes Kugelglas.  
Die Lampe ist mit einem Dimmer  
ausgestattet.

Lampe de table 4 points lumineux  
or brossé ou acier brossé  
et détails en bronze.  
Sphère en verre soufflé couleur opaline.  
Lampe équipée d'un variateur.

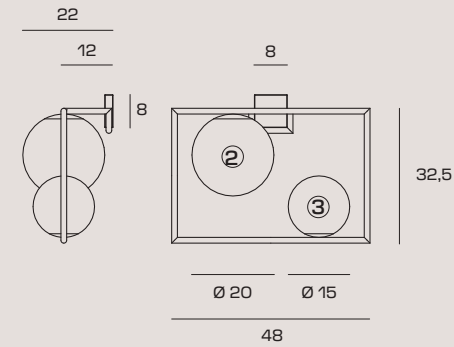
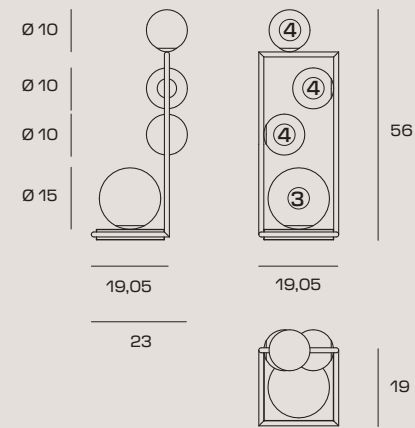

# BUBBLE

## WALL LAMP

Lampada da parete 2 luci  
in oro spazzolato o acciaio spazzolato  
e particolare in bronzo.  
Vetri sfera soffiati colore opalino.

2-light wall lamp,  
in brushed gold or brushed steel  
and bronze detail.  
Opaline blown sphere glass.

Wandleuchte 2 Lichter  
aus gebürstetem Gold oder  
gebürstetem Stahl mit Bronzedetails.  
Opalfarbenes geblasenes Kugelglas.

Applique 2 points lumineux  
or brossé ou acier brossé  
et détails en bronze.  
Sphère en verre soufflé  
couleur opaline.



CODE	1744.311	1744.362
COLOR	● Brushed Gold	● Brushed Steel
€ EXCL VAT	226,23	226,23

### LIGHT SOURCE

Source Source G9 LED DIMMABLE | Power 4 x max 20w  
Max bulb size: ③ : Ø50xH90mm  
④ : Ø20xH60mm



CODE	1744.336	1744.364
COLOR	● Brushed Gold	● Brushed Steel

### LIGHT SOURCE

Source E27 LED | Power 2 x max 20w  
Max bulb size: ② : Ø50xH140mm  
③ : Ø50xH90mm



# BUBBLE

## WALL LAMP

Lampada da parete 3 luci  
in oro spazzolato o acciaio spazzolato  
e particolare in bronzo.  
Vetri sfera soffiati colore opalino.

3-light wall lamp,  
in brushed gold or brushed steel  
and bronze detail.  
Opaline blown sphere glass.

Wandleuchte 3 Lichter  
aus gebürstetem Gold oder  
gebürstetem Stahl mit Bronzedetails.  
Opalfarbenes geblasenes Kugelglas.

Applique 3 points lumineux  
or brossé ou acier brossé  
et détails en bronze.  
Sphère en verre soufflé  
couleur opaline.

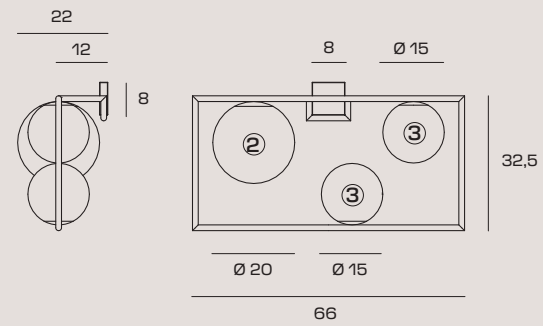

CODE	1744.337	1744.365
COLOR	● Brushed Gold	● Brushed Steel

### LIGHT SOURCE

Source E27 LED | Power 3 x max 20w  
Max bulb size: ② : Ø50xH140mm  
③ : Ø50xH90mm



# BUBBLE

## WALL LAMP

Lampada da parete 5 luci  
in oro spazzolato o acciaio spazzolato  
e particolare in bronzo.  
Vetri sfera soffiati colore opalino.

5-light wall lamp,  
in brushed gold or brushed steel  
and bronze detail.  
Opaline blown sphere glass.

Wandleuchte 5 Lichter  
aus gebürstetem Gold oder  
gebürstetem Stahl mit Bronzedetails.  
Opalfarbenes geblasenes Kugelglas.

Applique 5 points lumineux  
or brossé ou acier brossé  
et détails en bronze.  
Sphère en verre soufflé  
couleur opaline.

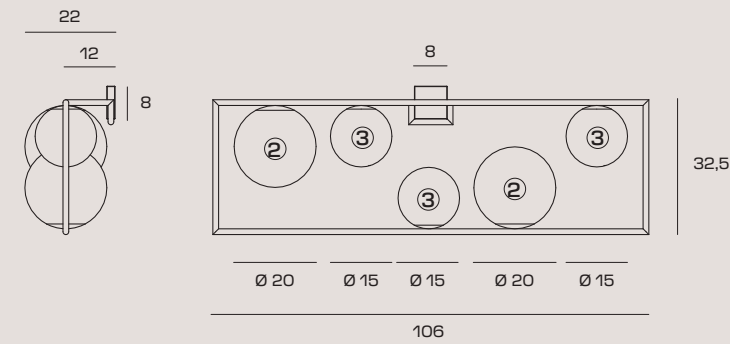

CODE	1744.338	1744.366
COLOR	● Brushed Gold	● Brushed Steel

### LIGHT SOURCE

Source E27 LED | Power 5 x max 20w  
Max bulb size: ② : Ø50xH140mm  
③ : Ø50xH90mm



# BUBBLE

## CEILING LAMP

Lampada da soffitto 3 luci  
in oro spazzolato o acciaio spazzolato  
e particolare in bronzo.  
Vetri sfera soffiati colore opalino.

3-light ceiling lamp,  
in brushed gold or brushed steel  
and bronze detail.  
Opaline blown sphere glass.

Deckenleuchte 3 Lichter  
aus gebürstetem Gold oder  
gebürstetem Stahl mit Bronzedetails.  
Opalfarbenes geblasenes Kugelglas.

Plafonnier 3 points lumineux  
or brossé ou acier brossé  
et détails en bronze.  
Sphère en verre soufflé  
couleur opaline.

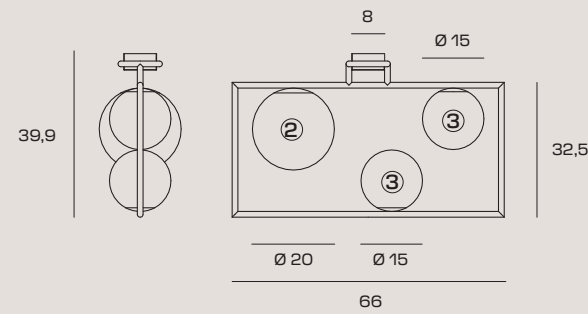

CODE	1744.342	1744.370
COLOR	● Brushed Gold	● Brushed Steel

### LIGHT SOURCE

Source E27 LED | Power 3 x max 20w  
Max bulb size: ②: Ø50xH140mm  
③: Ø50xH90mm



# BUBBLE

## FLOOR LAMP

Lampada da terra 6 luci  
in oro spazzolato o acciaio spazzolato  
e particolare in bronzo.  
Vetri sfera soffiati colore opalino.  
Lampada dotata di Dimmer.

6-light floor lamp,  
in brushed gold or brushed steel  
and bronze detail.  
Opaline blown sphere glass.  
Dimmerable.

Stehleuchte 6 Lichter  
in gebürstetem Gold oder  
gebürstetem Stahl mit Bronzedetails.  
Opalfarbenes geblasenes Kugelglas.  
Die Lampe ist mit einem  
Dimmer ausgestattet.

Lampadaire 6 points lumineux  
or brossé ou acier brossé  
et détails en bronze.  
Sphère en verre soufflé  
couleur opaline.  
Lampe équipée d'un variateur.

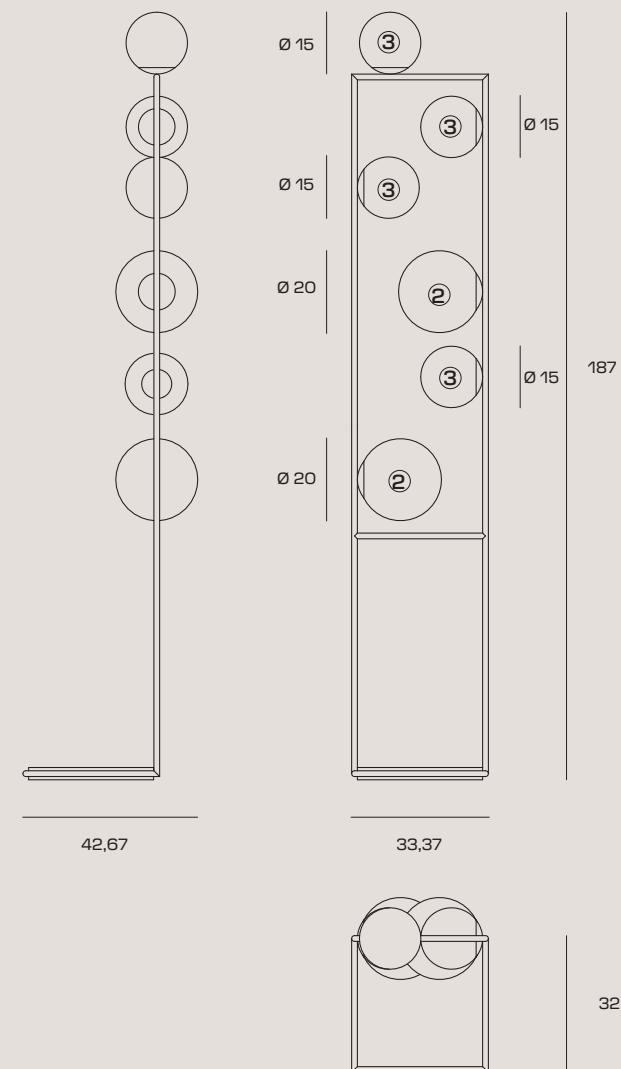

CODE	1744.341	1744.369
COLOR	● Brushed Gold	● Brushed Steel

### LIGHT SOURCE

Source E27 LED DIMMABLE | Power 6 x max 20w  
Max bulb size: ②: Ø50xH140mm  
③: Ø50xH90mm



# MOSE



## MOSE

La sinergia della molteplicità. A connotare Mose è la componente strutturale in cui cilindri di materiali raffinati come bronzo, ottone e rame dialogano fra loro offrendo composizioni con linguaggi differenti. Questa varietà trova raccordo nell'anello centrale, capace di collegare le parti e conferire preziosità e coerenza all'intera struttura. Mose raggiunge la sua massima espressione nelle composizioni multiple, in cui la varietà dei materiali e la capacità di connotare lo spazio trovano il proprio culmine.

The synergy of multiplicity. What characterises Mose is the structural component, with cylinders of refined materials such as bronze, brass and copper dialoguing with each other, offering compositions with different languages. This variety is jointed through the central ring, capable of connecting the parts and making the entire layout cohesive and precious. Mose reaches its highest expression in multiple compositions, in which the variety of materials and the ability to connote space find their culmination.

Die Synergie der Vielfaltigkeit. Charakteristisch für Mose ist die strukturelle Komponente, in der Zylinder aus veredelten Materialien wie Bronze, Messing und Kupfer miteinander in Dialog treten und Kompositionen mit unterschiedlichen Sprachen bieten. Diese Vielfalt findet ihre Verbindung im zentralen Ring, der die Teile miteinander verbindet und der gesamten Struktur Wertigkeit und Kohärenz verleiht. Mose erreicht ihren höchsten Ausdruck in multiplen Kompositionen, in denen die Vielfalt der Materialien und die Fähigkeit, Raum zu konnotieren, ihren Höhepunkt finden.

La synergie de la multiplicité. Mose se caractérise par sa structure où dialoguent des cylindres de matériaux raffinés comme le bronze, le laiton et le cuivre, offrant des compositions aux langages différents. Cette diversité trouve une unification dans l'anneau central, qui relie les différents éléments et confère raffinement et cohérence à l'ensemble de la structure. Mose atteint sa plus haute expression dans les compositions multiples, où la diversité des matériaux et la faculté de connoter l'espace atteignent leur sommet.







# MOSE

SUSPENSION



# MOSE

SUSPENSION



# MOSE

SUSPENSION





# MOSE

TABLE



# MOSE

WALL | CEILING LAMP



# MOSE

## SUSPENSION

Lampada a sospensione  
in vetro soffiato bianco latte.  
Montatura in metallo  
verniciato nero soft-touch,  
con particolari in ottone spazzolato,  
rame spazzolato e bronzo spazzolato.

Pendant lamp in milk white blown glass.  
Black soft-touch painted metal frame,  
with details in brushed brass,  
brushed copper and brushed bronze.

Pendelleuchte aus  
geblasenem Glas in Milchweiß.  
Fassungsstruktur aus Metall lackiert  
mit schwarzem Soft-Touch-Lack,  
Details aus gebürstetem Messing,  
Kupfer und Bronze.

Suspension  
en verre soufflé blanc laiteux.  
Monture en métal  
peinte en noir soft touch,  
détails en laiton brossé,  
cuivre brossé et bronze brossé.

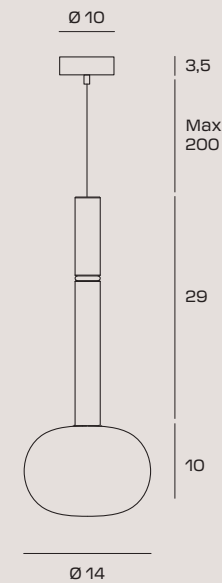
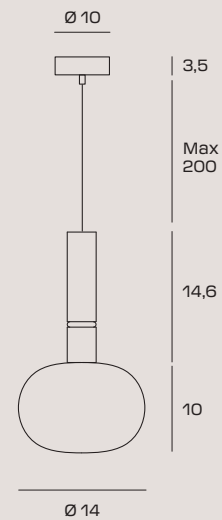

# MOSE

## SUSPENSION

Lampada a sospensione  
in vetro soffiato bianco latte.  
Montatura in metallo  
verniciato nero soft-touch,  
con particolari in ottone spazzolato,  
rame spazzolato e bronzo spazzolato.

Pendant lamp in milk white blown glass.  
Black soft-touch painted metal frame,  
with details in brushed brass,  
brushed copper and brushed bronze.

Pendelleuchte aus  
geblasenem Glas in Milchweiß.  
Fassungsstruktur aus Metall lackiert  
mit schwarzem Soft-Touch-Lack,  
Details aus gebürstetem Messing,  
Kupfer und Bronze.

Suspension  
en verre soufflé blanc laiteux.  
Monture en métal  
peinte en noir soft touch,  
détails en laiton brossé,  
cuivre brossé et bronze brossé.



CODE	1744.223.KIT	1744.224.KIT	1744.225.KIT
DETAILS	● Brushed Gold	● Brushed Bronze	● Brushed Copper
COLOR	● Black	● Black	● Black

### LIGHT SOURCE

G9 LED | 1 x max 28w  
Max bulb size: Ø20xH60mm



CODE	1744.226.KIT	1744.227.KIT	1744.228.KIT
DETAILS	● Brushed Gold	● Brushed Bronze	● Brushed Copper
COLOR	● Black	● Black	● Black

### LIGHT SOURCE

G9 LED | 1 x max 28w  
Max bulb size: Ø20xH60mm



# MOSE

## SUSPENSION

Lampada a sospensione in vetro soffiato bianco latte. Montatura in metallo verniciato nero soft-touch, con particolari in ottone spazzolato, rame spazzolato e bronzo spazzolato.

Pendant lamp in milk white blown glass. Black soft-touch painted metal frame, with details in brushed brass, brushed copper and brushed bronze.

Pendelleuchte aus geblasenem Glas in Milchweiß. Fassungsstruktur aus Metall lackiert mit schwarzem Soft-Touch-Lack, Details aus gebürstetem Messing, Kupfer und Bronze.

Suspension en verre soufflé blanc laiteux. Monture en métal peint noir soft touch avec détails en laiton brossé, cuivre brossé et bronze brossé.



CODE	1744.229.KIT	1744. 230.KIT	1744.231.KIT
DETAILS	Brushed Gold	Brushed Bronze	Brushed Copper
COLOR	Black	Black	Black

### LIGHT SOURCE

G9 LED | 1 x max 28w  
Max bulb size: Ø20xH60mm



# MOSE

## SUSPENSION

Lampada a sospensione in vetro soffiato bianco latte. Montatura in metallo verniciato nero soft-touch, con particolari in ottone spazzolato, rame spazzolato e bronzo spazzolato.

Pendant lamp in milk white blown glass. Black soft-touch painted metal frame, with details in brushed brass, copper brushed and brushed bronze.

Pendelleuchte aus geblasenem Glas in Milchweiß. Fassungsstruktur aus Metall lackiert mit schwarzem Soft-Touch-Lack, Details aus gebürstetem Messing, Kupfer und Bronze.

Suspension en verre soufflé blanc laiteux. Monture en métal peint noir soft touch avec détails en laiton brossé, cuivre brossé et bronze brossé.

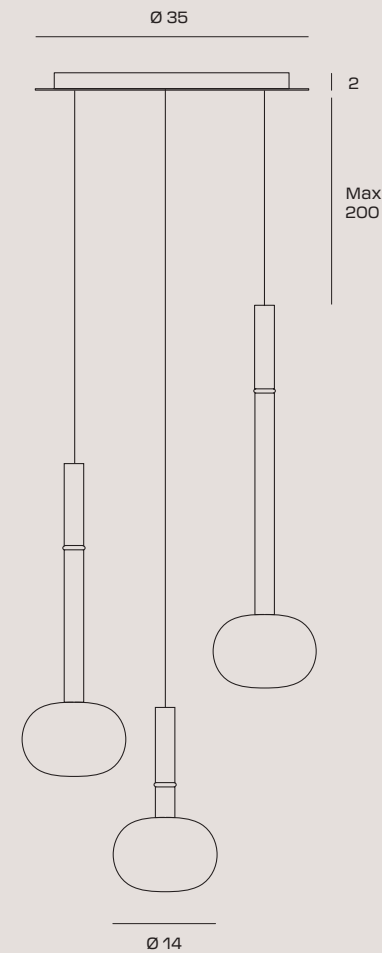

CODE	1744.232.KIT		
DETAILS	Brushed Gold	Brushed Bronze	Brushed Copper
COLOR	Black		

### LIGHT SOURCE

G9 LED | 3 x max 28w  
Max bulb size: Ø20xH60mm



# MOSE

## SUSPENSION





Lampada a sospensione  
in vetro soffiato bianco latte.  
Montatura in metallo verniciato  
nero soft-touch, con particolari in  
ottone spazzolato rame spazzolato  
e bronzo spazzolato.

Pendant lamp in milk white blown glass.  
Black soft-touch painted metal frame,  
with details in brushed brass,  
brushed copper and brushed bronze.

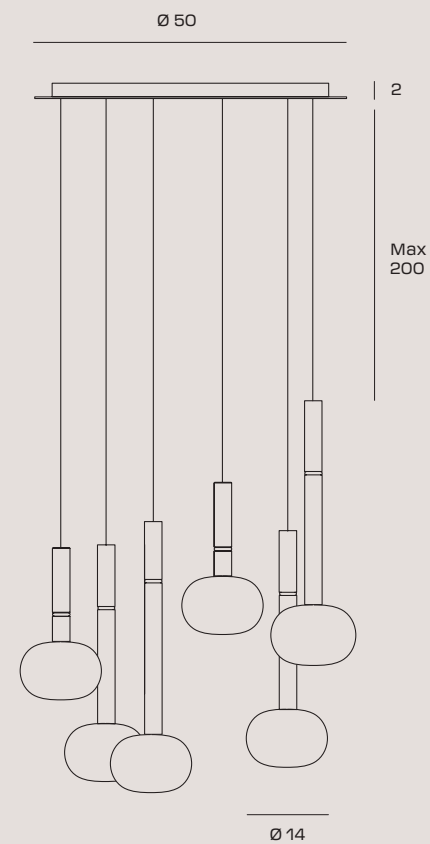
Pendelleuchte aus geblasenem Glas  
in Milchweiß. Fassungsstruktur aus Metall  
lackiert mit schwarzem Soft-Touch-Lack,  
Details aus gebürstetem  
Messing Kupfer und Bronze.

Suspension  
en verre soufflé blanc laiteux.  
Monture en métal peint  
noir soft touch avec détails en  
laiton brossé, cuivre brossé  
et bronze brossé.



CODE	1744.233.KIT
DETAILS	 Brushed Gold  Brushed Bronze  Brushed Copper
COLOR	 Black

### LIGHT SOURCE

 G9 LED | 6 x max 28w  
Max bulb size: Ø20xH60mm



# MOSE

## SUSPENSION





Lampada a sospensione  
in vetro soffiato bianco latte.  
Montatura in metallo verniciato  
nero soft-touch, con particolari in  
ottone spazzolato rame spazzolato  
e bronzo spazzolato.

Pendant lamp in milk white blown glass.  
Black soft-touch painted metal frame,  
with details in brushed brass,  
brushed copper and brushed bronze.

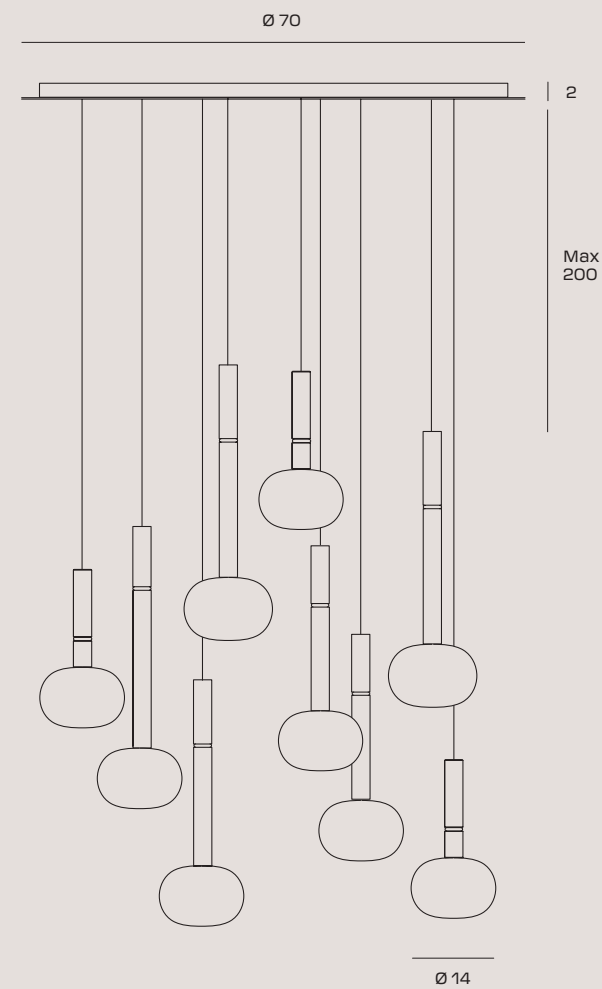
Pendelleuchte aus geblasenem Glas  
in Milchweiß. Fassungsstruktur aus Metall  
lackiert mit schwarzem Soft-Touch-Lack,  
Details aus gebürstetem  
Messing Kupfer und Bronze.

Suspension  
en verre soufflé blanc laiteux.  
Monture en métal peint  
noir soft touch avec détails en  
laiton brossé, cuivre brossé  
et bronze brossé.



CODE	1744.234.KIT
DETAILS	 Brushed Gold  Brushed Bronze  Brushed Copper
COLOR	 Black

### LIGHT SOURCE

 G9 LED | 9 x max 28w  
Max bulb size: Ø20xH60mm



# MOSE

## TABLE

Lampada da tavolo  
in vetro soffiato bianco latte.  
Montatura in metallo verniciato  
nero soft-touch, con particolari  
in ottone spazzolato, rame spazzolato,  
bronzo spazzolato.  
Lampada dotata di dimmer.

Table lamp In milk white blown glass.  
Black soft-touch painted metal frame,  
with details in brushed brass,  
brushed copper, brushed bronze.  
Dimmable lamp.

Tischleuchte mit Kugelglas aus  
geblasenem Glas in Milchweiß.  
Standfuß aus Metall lackiert  
mit schwarzem Soft-Touch-Lack.  
Details aus gebürstetem Messing,  
Kupfer und Bronze.  
Ausgestattet mit Dimmer.

Lampe de table  
en verre soufflé blanc laiteux.  
Monture en métal peint  
noir soft touch avec détails en  
laiton brossé, cuivre brossé  
et bronze brossé.  
Lampe équipée d'un variateur.

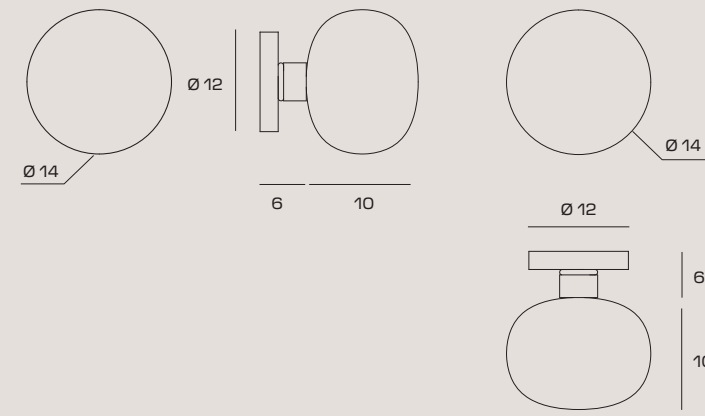
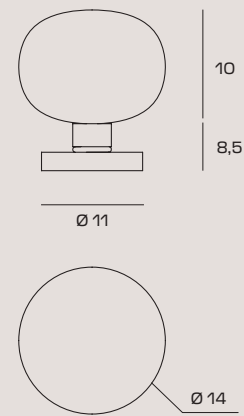

# MOSE

## WALL / CEILING LAMP

Lampada da parete o soffitto  
in vetro soffiato bianco latte.  
Montatura in metallo  
verniciato nero soft-touch,  
con particolari in ottone spazzolato,  
rame spazzolato, bronzo spazzolato.

Wall and ceiling lamp  
in milk white blown glass.  
Black soft-touch painted metal frame,  
with details in brushed brass,  
brushed copper, brushed bronze.

Wand- und Deckenleuchte  
mit Kugelglas aus geblasenem Glas  
in Milchweiß. Halterung aus Metall lackiert  
mit schwarzem Soft-Touch-Lack.  
Details aus gebürstetem Messing,  
Kupfer und Bronze.

Applique ou plafonnier  
en verre soufflé blanc laiteux.  
Monture en métal  
peinte en noir soft touch,  
détails en laiton brossé,  
cuivre brossé et bronze brossé.

CODE	1744.196		
DETAILS	<span style="color: red;">●</span> Brushed Bronze	<span style="color: gold;">●</span> Brushed Gold	<span style="color: brown;">●</span> Brushed Copper
COLOR	<span style="color: black;">●</span> Black		

### LIGHT SOURCE

 G9 LED DIMMABLE | 1 x max 10w  
Max bulb size: Ø20xH60mm



CODE	1744.197		
DETAILS	<span style="color: red;">●</span> Brushed Bronze	<span style="color: gold;">●</span> Brushed Gold	<span style="color: brown;">●</span> Brushed Copper
COLOR	<span style="color: black;">●</span> Black		

### LIGHT SOURCE

 G9 LED | 1 x max 10w  
Max bulb size: Ø20xH60mm



# MOSE

**PERSONALIZZAZIONE MOSE SOSPENSIONE**  
**CUSTOMIZATION FOR MOSE SUSPENSION LIGHT**  
**PERSONALISIERUNG MOSE PENDELLEUCHTE**  
**PERSONNALISATION MOSE SUSPENSION**

Possibilità creare una configurazione personalizzata a **1, 3, 6, 9 luci** con le sospensioni Mose in varie dimensioni e colori diversi: oro spazzolato, bronzo spazzolato e rame spazzolato. Cavo nero. Lunghezza max 200 cm.

Possibility to create a customised configuration with **1, 3, 6, 9 lights** with Mose pendant lamps in various sizes and different colours: brushed gold, brushed bronze and brushed copper. Black cable. Max. length: 200 cm.

Es besteht die Möglichkeit, eine individuelle Konfiguration von **1, 3, 6 oder 9 Lichter** mit Mose-Aufhängungen in verschiedenen Größen und Farben zu erstellen: gebürstetes Gold, gebürstete Bronze und gebürstetes Kupfer. Schwarzes Kabel. Max. Länge 200 cm.

Possibilité de créer une configuration personnalisée à **1, 3, 6, 9 points lumineux** avec des suspensions Mose de dimensions variées et différentes couleurs : or brossé, bronze brossé et cuivre brossé. Câble noir. Longueur max. 200 cm.

## GLASS

**FORMA/SHAPE/BILDEN/FORME**      **COLORI/COLORS/FARBEN/COULEURS**

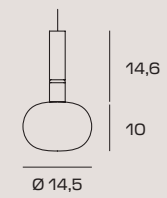

CODE	1744.187	1744.188	1744.189
DETAILS	Brushed Gold	Brushed Bronze	Brushed Copper
COLOR	Black	Black	Black

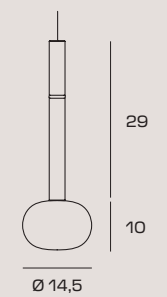

CODE	1744.190	1744.191	1744.192
DETAILS	Brushed Gold	Brushed Bronze	Brushed Copper
COLOR	Black	Black	Black

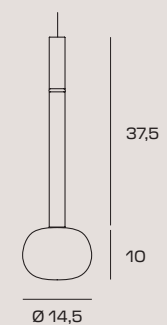

CODE	1744.193	1744.194	1744.195
DETAILS	Brushed Gold	Brushed Bronze	Brushed Copper
COLOR	Black	Black	Black

## ROSONI A SOFFITTO

**CEILING CANOPY**  
**DECKENLAMPEN**  
**ROSACES DE PLAFOND**

Rosone tondo diametro 10 cm per sospensioni a **1 luce** in colore Nero. Cavi non inclusi.  
 Black, round ceiling canopy 10 cm diameter for **1-light** suspensions. Cables not included.  
 Schwarze runde Rosette mit 10 cm Durchmesser für **1-flammige** Pendelleuchten. Kabel nicht enthalten.  
 Rosace ronde diamètre 10 cm pour suspension à **1 lumière**, finition noir. Câbles non inclus.

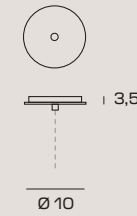

CODE 1744.M.183

Rosone circolare diametro 35 cm per sospensioni a **3 luci** in colore Nero. Cavi non inclusi.  
 Black, round ceiling canopy 35 cm diameter for **3-light** suspensions. Cables not included.  
 Schwarze runde Rosette mit 35 cm Durchmesser für **3-flammige** Pendelleuchten. Kabel nicht enthalten.  
 Rosace ronde diamètre 35 cm pour suspensions à **3 lumières**, finition noir. Câbles non inclus.

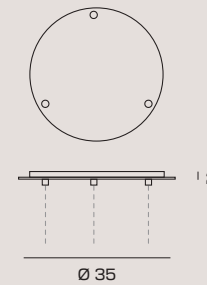

CODE 1744.M.184

Rosone circolare diametro 50 cm per sospensioni a **6 luci** in colore Nero. Cavi non inclusi.  
 Black, round ceiling canopy 50 cm diameter for **6-light** suspensions. Cables not included.  
 Schwarze runde Rosette mit 50 cm Durchmesser für **6-flammige** Pendelleuchten. Kabel nicht enthalten.  
 Rosace ronde diamètre 50 cm pour suspensions **6 lumières**, finition noir. Câbles non inclus.

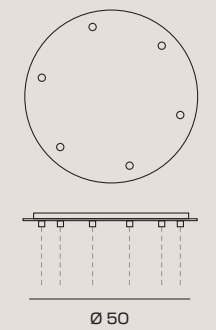

CODE 1744.M.185

Rosone circolare diametro 70 cm per sospensioni a **9 luci** in colore Nero. Cavi non inclusi.  
 Black, round ceiling canopy 70 cm diameter for **9-light** suspensions. Cables not included.  
 Schwarze runde Rosette mit 70 cm Durchmesser für **9-flammige** Pendelleuchten. Kabel nicht enthalten.  
 Rosace ronde diamètre 70 cm pour suspensions **9-lumières**, finition noir. Câbles non inclus.

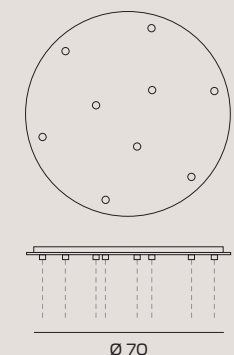

CODE 1744.M.186



# DOMU

## DOMU

Raffinato omaggio alla classicità. Le forme geometriche essenziali di Domu trovano l'apice nel segno a mo' di cupola in vetro soffiato, caratterizzato da geometrie che appartengono alla nostra cultura e - al contempo - elevano la percezione della lampada. Il tocco di personalità di Domu risiede nell'anello metallico che le cinge il corpo e nella possibilità, offerta nella versione da tavolo, di dimmerare la fonte luminosa rendendo l'ambiente caldo ed accogliente.

A refined homage to classicism. Domu's essential geometric shapes find their peak in the domed sign made of blown glass, characterised by geometries that belong to our culture and - at the same time - elevate the perception of the lamp. Domu's touch of personality lies in the metal ring that encircles its body and in the possibility of dimming the light source in the table version, making the environment warm and welcoming.

Raffinierte Hommage an den Klassizismus. Die essentiellen geometrischen Formen von Domu finden ihren Höhepunkt in dem gewölbten Schild aus mundgeblasenem Glas, das von Geometrien geprägt ist, die zu unserer Kultur gehören und gleichzeitig die Wahrnehmung der Lampe erhöhen. Der persönliche Touch von Domu liegt in dem Metallring, der den Körper umgibt, und in der Möglichkeit, die Lichtquelle zu dimmen, die in der Tischversion angeboten wird und die Umgebung warm und einladend macht.

Un hommage raffiné au classicisme. Les formes géométriques essentielles de Domu trouvent leur apogée dans le signe en forme de dôme en verre soufflé, caractérisé par des géométries qui appartiennent à notre culture et - en même temps - élèvent la perception de la lampe. La touche de personnalité de Domu réside dans l'anneau métallique qui entoure son corps et dans la possibilité, offerte dans la version de table, d'atténuer la source lumineuse en rendant l'environnement chaleureux et accueillant.

# DOMU

SUSPENSION





# DOMU

WALL | CEILING LAMP





# DOMU

WALL | CEILING LAMP





# DOMU

TABLE



# DOMU

## SUSPENSION

Lampada da sospensione in bronzo.  
Vetro bianco latte.  
Attacco lampadina GX53.

Bronze pendant lamp.  
Milk-white glass.  
GX53 bulb socket.

Hängeleuchte aus Bronze.  
Milchweißes Glas.  
Lampenfassung GX53.

Suspension en bronze.  
Verre blanc laiteux.  
Douille ampoule GX53.

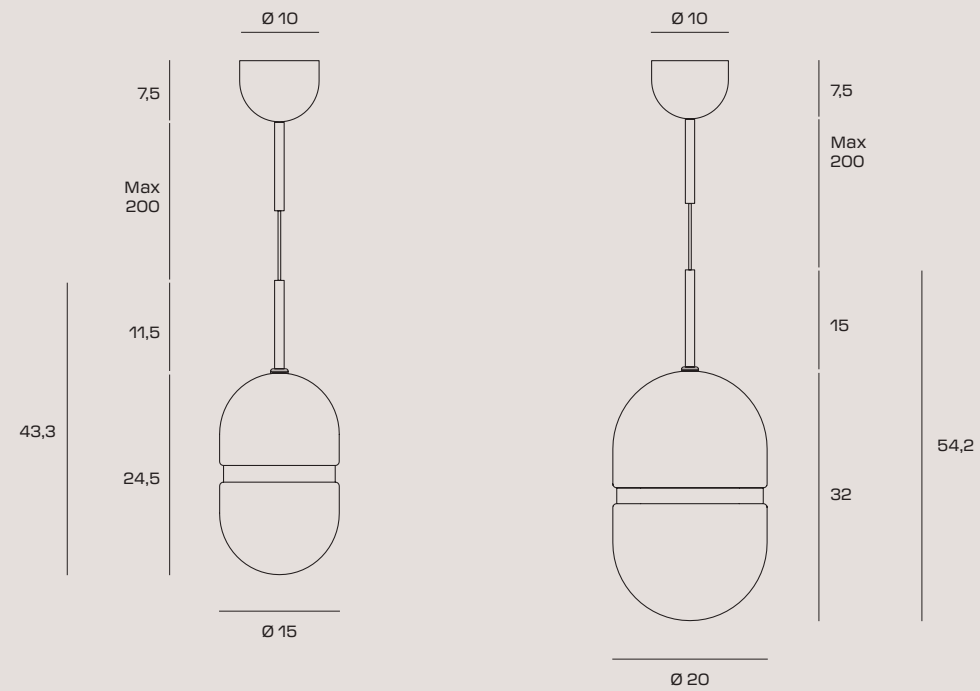

# DOMU

## SUSPENSION

Lampada da sospensione in bronzo.  
Vetro bianco latte.  
Attacco lampadina GX53.

Bronze pendant lamp.  
Milk-white glass.  
GX53 bulb socket.

Hängeleuchte aus Bronze.  
Milchweißes Glas.  
Lampenfassung GX53.

Suspension en bronze.  
Verre blanc laiteux.  
Douille ampoule GX53.

CODE	1744.384
COLOR	● Bronze

### LIGHT SOURCE

 Source | GX53 LED | Power | 2 x max 10w



CODE	1744.385
COLOR	● Bronze

### LIGHT SOURCE

 Source | GX53 LED | Power | 2 x max 10w



# DOMU

## TABLE

Lampada da tavolo in bronzo.  
Vetro bianco latte.  
Attacco lampadina GX53.

Bronze table lamp.  
Milk-white glass.  
GX53 bulb socket.

Tischlampe aus Bronze.  
Milchweißes Glas.  
Lampenfassung GX53.

Lampe de table en bronze.  
Verre blanc laiteux.  
Douille ampoule GX53.

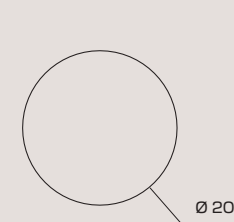
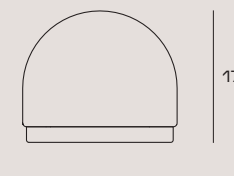
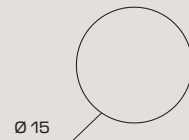
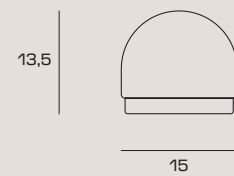

# DOMU

## TABLE

Lampada da tavolo in bronzo.  
Vetro bianco latte.  
Attacco lampadina GX53.

Bronze table lamp.  
Milk-white glass.  
GX53 bulb socket.

Tischlampe aus Bronze.  
Milchweißes Glas.  
Lampenfassung GX53.

Lampe de table en bronze.  
Verre blanc laiteux.  
Douille ampoule GX53.

CODE	1744.382
COLOR	● Bronze
€ EXCL VAT	90,98

### LIGHT SOURCE

 Source | GX53 LED DIMMABLE | Power | 1 x max 10w



CODE	1744.383
COLOR	● Bronze

### LIGHT SOURCE

 Source | GX53 LED DIMMABLE | Power | 1 x max 10w



# DOMU

WALL / CEILING LAMP

Lampada da parete o soffitto in bronzo.  
Vetro bianco latte.  
Attacco lampadina GX53.

Bronze wall or ceiling lamp.  
Milk-white glass.  
GX53 bulb socket.

Wand- oder Deckenleuchte aus Bronze.  
Milchweißes Glas.  
Lampenfassung GX53.

Applique ou plafonnier en bronze.  
Verre blanc laiteux.  
Douille ampoule GX53.

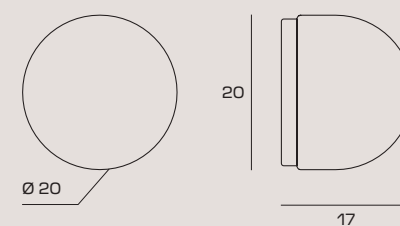
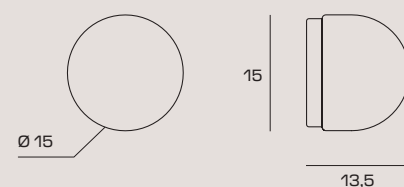

# DOMU

WALL / CEILING LAMP

Lampada da parete o soffitto in bronzo.  
Vetro bianco latte.  
Attacco lampadina GX53.

Bronze wall or ceiling lamp.  
Milk-white glass.  
GX53 bulb socket.

Wand- oder Deckenleuchte aus Bronze.  
Milchweißes Glas.  
Lampenfassung GX53.

Applique ou plafonnier en bronze.  
Verre blanc laiteux.  
Douille ampoule GX53.

CODE	1744.380
COLOR	● Bronze

## LIGHT SOURCE

 Source | GX53 LED | Power | 1 x max 10w



CODE	1744.381
COLOR	● Bronze

## LIGHT SOURCE

 Source | GX53 LED | Power | 1 x max 10w





# COSMO

## COSMO

La magia di un cielo notturno punteggiato dal bagliore delle stelle. Cosmo rende il fascino delle costellazioni accessibile a tutti, facendo dello spettacolo della luminosità l'assoluto protagonista. La trasparenza della sfera esterna, custode del punto luce interno in vetro satinato, alleggerisce la composizione e permette alla luce di diffondersi in tutto il suo splendore. I dettagli dorati di Cosmo impreziosiscono ogni ambiente in cui è posta.

The magic of a night sky dotted with glowing stars. Cosmo makes the fascination of constellations accessible to all, making this glowing show the absolute protagonist. The transparency of the outer sphere, guardian of the internal satin-finish glass light point, lightens up the composition and allows the light to spread in all its splendour. Cosmo's golden details embellish any environment in which it is placed.

Die Magie eines nächtlichen Sternenhimmels, der mit dem Glühen der Sterne übersät ist. Cosmo macht die Faszination der Sternbilder für alle zugänglich und macht das Spektakel der Helligkeit zum absoluten Star. Die Transparenz der äußeren Kugel, die über den inneren Lichtpunkt aus Milchglas wacht, hellt die Komposition auf und lässt das Licht in seiner ganzen Pracht verbreiten. Die goldenen Details von Cosmo verschönern jeden Raum, in dem sie aufgestellt wird.

La magie d'un ciel nocturne ponctué de la lueur des étoiles. Cosmo rend la fascination des constellations accessible à tous avec, au premier plan, le spectacle de la luminosité. La transparence de la sphère extérieure, gardienne du point lumineux interne en verre satiné, allège la composition et permet à la lumière de se diffuser dans toute sa splendeur. Les détails dorés de Cosmo raffinent tous les types d'espaces.



# COSMO

SUSPENSION



# COSMO

TABLE



# COSMO

TABLE





# COSMO

WALL / CEILING LAMP



# COSMO

CEILING LAMP

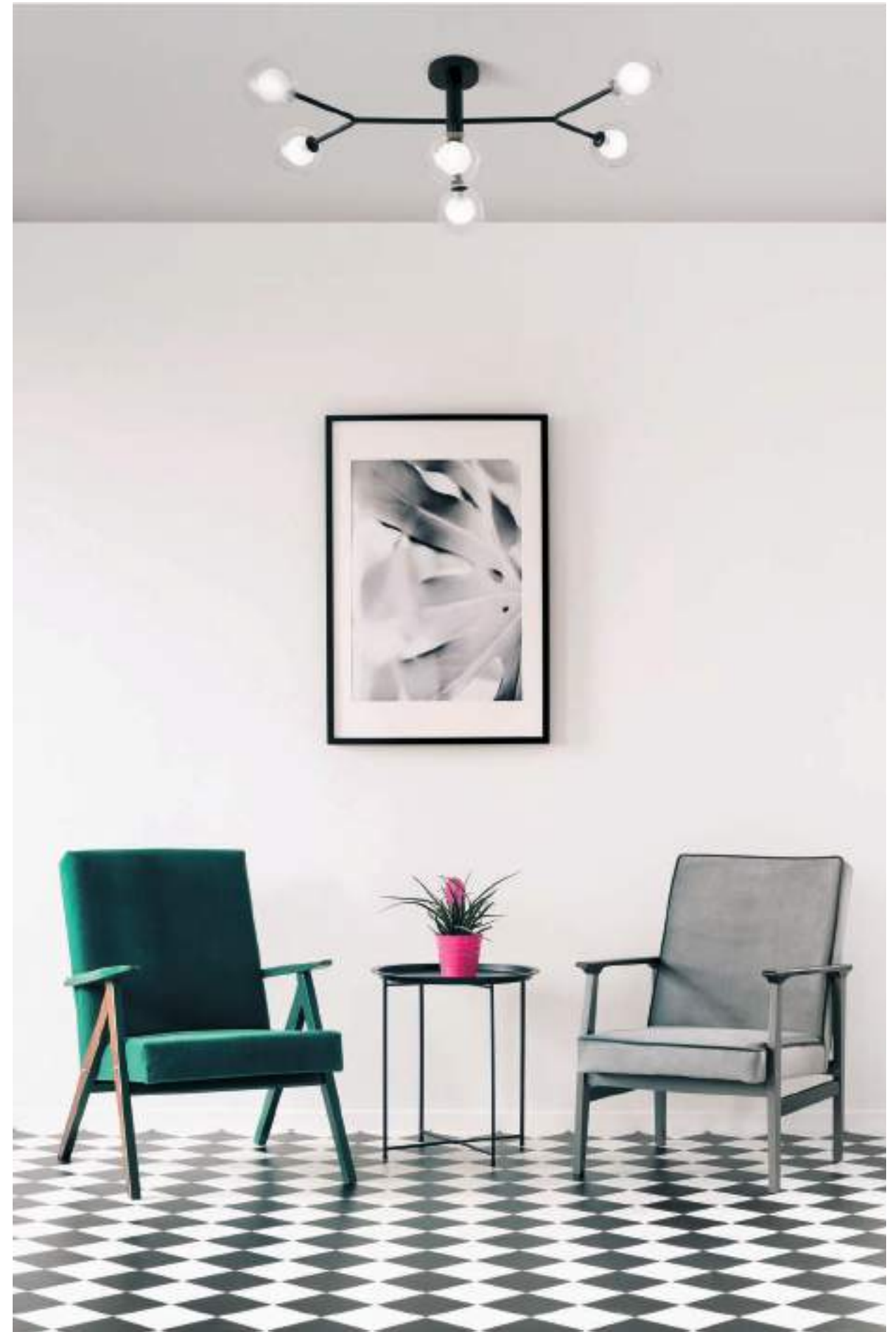



# COSMO

FLOOR LAMP



# COSMO

## FLOOR LAMP

Lampada da terra a 5 luci  
in vetro borosilicato trasparente  
con sfera interna satinata.  
Montatura in metallo verniciato nero  
con particolare in oro spazzolato.  
Cavo dotato di dimmer.

5-light ground lamp made of  
transparent borosilicate glass  
with satin-finish sphere on the inside.  
Black painted metal support  
with brushed gold detail.  
Cable with dimmer.

Bodenleuchte mit 5 Lichtern  
aus transparentem Borosilikatglas  
mit satinierter Innenkugel.  
Schwarz lackiertes Metallgestell mit  
goldfarbenen gebürsteten Details.  
Kabel mit Dimmer.

Lampadaire 5 points lumineux  
en verre borosilicate transparent  
avec sphère intérieure satinée.  
Monture en métal peinte en noir  
avec détails or brossé.  
Câble avec variateur.

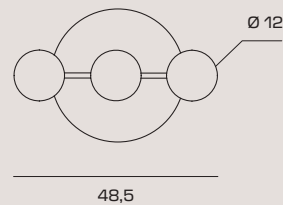
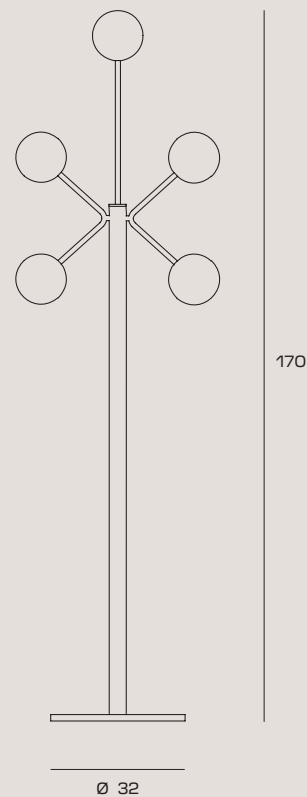

CODE 1744.168

COLOR ● Black

### LIGHT SOURCE

Source G9 LED DIMMABLE | Power 5 x max 10w  
Max bulb size: Ø20xH70mm



# COSMO

## SUSPENSION

Sospensione a 8 luci  
in vetro borosilicato trasparente  
con sfera interna satinata.  
Montatura in metallo verniciato nero  
con particolare in oro spazzolato.  
La lampada è dotata di due tubi  
utilizzabili per alzare e abbassare  
la lampada stessa.

8-light suspension lamp  
made of transparent borosilicate glass  
with satin-finish sphere on the inside.  
Black painted metal finish with  
brush gold detail.  
The lamp is equipped with two pipes  
that can be used to lower or lift it.

Hängeleuchte mit 8 Lichtern  
aus transparentem Borosilikatglas  
mit satinierter Innenkugel. Schwarz  
lackiertes Metallgestell mit goldfarbenen  
gebürsteten Details.  
Die Leuchte ist mit zwei Rohren  
ausgestattet, die zum Heben und Senken  
der Leuchte verwendet werden können.

Suspension à 8 points lumineux  
en verre borosilicate transparent  
avec sphère intérieure satinée.  
Monture en métal peinte en noir  
avec détails or brossé.  
La lampe est équipée de deux tubes  
permettant de la remonter et de  
l'abaisser.

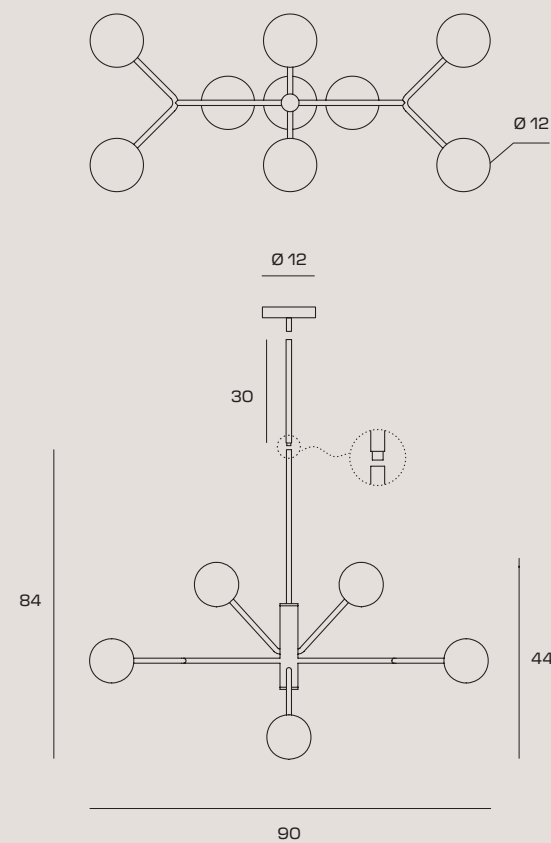

CODE 1744.164

COLOR ● Black

### LIGHT SOURCE

Source G9 LED | Power 8 x max 10w  
Max bulb size: Ø20xH70mm



# COSMO

## TABLE

Lampada da tavolo a 1 luce  
in vetro borosilicato trasparente  
con sfera interna satinata.  
Montatura in metallo verniciato nero  
con particolare in oro spazzolato.  
Cavo dotato di dimmer.

1-light table lamp  
made of transparent borosilicate glass  
with satin-finish sphere on the inside.  
Black painted metal finish  
with brush gold detail.  
Cable with dimmer.

Tischleuchte mit 1 Licht aus transparentem  
Borosilikatglas mit satinierter Innenkugel.  
Schwarz lackiertes Metallgestell mit  
goldfarbenen gebürsteten Details.  
Kabel mit Dimmer.

Lampe de table 1 point lumineux  
en verre borosilicate transparent  
avec sphère intérieure satinée.  
Monture en métal peinte en noir  
avec détails or brossé.  
Câble avec variateur.

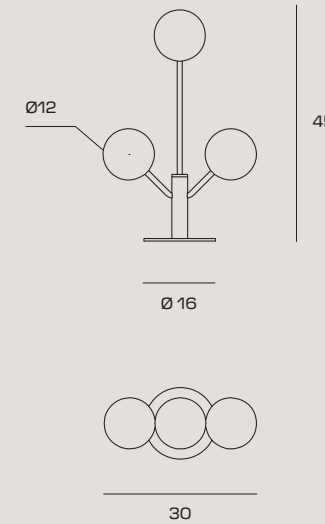
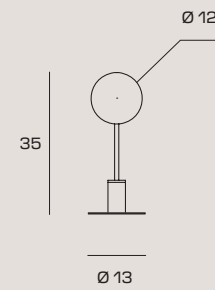

# COSMO

## TABLE

Lampada da tavolo a 3 luci in vetro  
in vetro borosilicato trasparente  
con sfera interna satinata.  
Montatura in metallo verniciato nero  
con particolare in oro spazzolato.  
Cavo dotato di dimmer.

3-light glass table lamp made of  
transparent borosilicate glass  
with satin-finish sphere on the inside.  
Black painted metal support  
with brushed gold detail.  
Cable with dimmer.

Tischleuchte mit 3 Lichtern  
aus transparentem Borosilikatglas  
mit satinierter Innenkugel.  
Schwarz lackiertes Metallgestell  
mit goldfarbenen gebürsteten Details.  
Kabel mit Dimmer.

Lampe de table 3 point lumineux  
en verre borosilicate transparent  
avec sphère intérieure satinée.  
Monture en métal peinte en noir  
avec détails or brossé.  
Câble avec variateur.

CODE 1744.171

COLOR ● Black

### LIGHT SOURCE

Source G9 LED DIMMABLE | Power 1 x max 10w  
Max bulb size: Ø20xH70mm

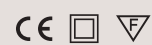

CODE 1744.169

COLOR ● Black

### LIGHT SOURCE

Source G9 LED DIMMABLE | Power 3 x max 10w  
Max bulb size: Ø20xH70mm



# COSMO

## WALL | CEILING LAMP

Lampada da parete o soffitto a 1 luce  
in vetro borosilicato trasparente  
con sfera interna satinata.  
Montatura in metallo verniciato nero  
con particolare in oro spazzolato.

1-light wall/ceiling lamp  
made of transparent borosilicate glass  
with satin-finish sphere on the inside.  
Black painted metal finish with  
brush gold detail.

Wand- oder Deckenleuchte mit 1 Licht  
aus transparentem Borosilikatglas  
mit satinierter Innenkugel.  
Schwarz lackiertes Metallgestell  
mit goldfarbenen gebürsteten Details.

Applique ou plafonnier 1 point lumineux  
en verre borosilicate transparent  
avec sphère intérieure satinée.  
Monture en métal peinte en noir  
avec détails or brossé.

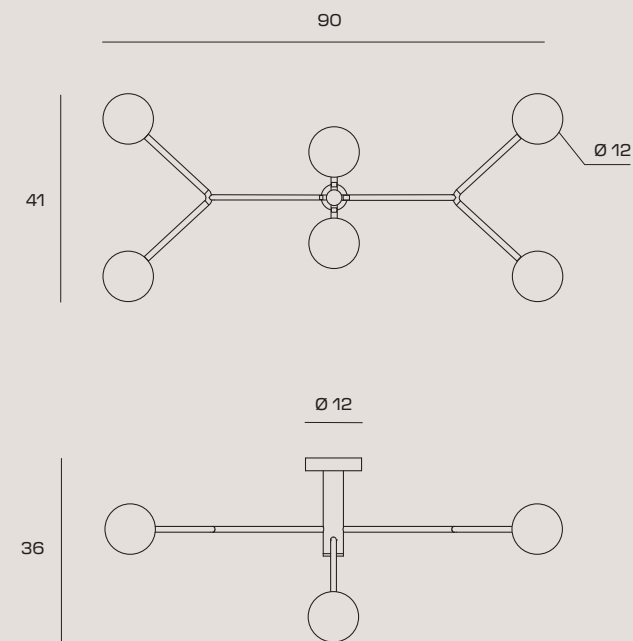
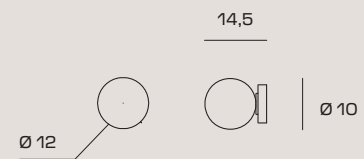

# COSMO

## CEILING LAMP

Lampada da soffitto 6 luci  
in vetro borosilicato trasparente  
con sfera interna satinata.  
Montatura in metallo verniciato nero  
con particolare in oro spazzolato.

6-light ceiling lamp  
made of transparent borosilicate glass  
with satin-finish sphere on the inside.  
Black painted metal finish with  
brush gold detail.

Deckenleuchte 6 Lichtern  
aus transparentem Borosilikatglas  
mit satinierter Innenkugel.  
Schwarz lackiertes Metallgestell  
mit goldfarbenen gebürsteten Details.

Plafonnier 6 points lumineux  
en verre borosilicate transparent  
avec sphère intérieure satinée.  
Monture en métal peinte en noir  
avec détails or brossé.

CODE 1744.167

COLOR ● Black

### LIGHT SOURCE

Source G9 LED | Power 3 x max 10w  
Max bulb size: Ø20xH70mm



CODE 1744.165

COLOR ● Black

### LIGHT SOURCE

Source G9 LED | Power 6 x max 10w  
Max bulb size: Ø20xH70mm





# WIRE

## WIRE

Il volume c'è, ma non si percepisce. Wire si distingue per una presenza importante a livello dimensionale, senza per questo risultare eccessiva. Il gioco di pieni e vuoti creato dal tondino di filo crea una leggera gabbia che custodisce un classico punto luce a sfera in vetro opalino e rende Wire moderna, delicata e, al contempo, di forte impatto visivo.

Its volume is unperceived. Wire stands out for its huge yet not at all excessive size. The interplay of solids and voids created by the Wire rod is shaped into a light cage, guarding a classic opal glass ball light, and making Wire modern, delicate, and with a strong visual impact.

Das Volumen ist da, aber nicht spürbar. Wire zeichnet sich durch eine wuchtige Präsenz in Bezug auf die Größe aus, ohne jedoch exzessiv zu wirken. Das Spiel aus Leer- und Füllräumen, das vom Drahtgestell erzeugt wird, schafft einen leichten Käfig, der eine klassische kugelförmige Lichtquelle aus Opalglas birgt und macht Wire modern und zart mit gleichzeitig starker optischer Wirkung.

Le volume existe, mais il n'est pas perçu. Wire se distingue par une présence importante au niveau dimensionnel, sans pour autant être excessive. Le jeu de pleins et de vides créé par le tube rond de fil crée une cage légère qui conserve un point lumineux à sphère classique en verre opalin et rend Wire moderne, délicat avec un fort impact visuel.



# WIRE

SUSPENSION







# WIRE

TABLE



# WIRE

## SUSPENSION

Lampada a sospensione con struttura in tondino metallico finitura oro spazzolato o verniciata nero opaco. Diffusore interno in vetro opalino. Rosone in oro spazzolato o verniciato nero opaco. Cavo di alimentazione nero 200 cm. Lampadina installabile G9 a LED.

Suspension lamp with metal rod frame in brushed gold or painted matte black finish. Internal opal glass diffuser. Brushed gold or painted black matte ceiling canopy. Black 200 cm power supply cord. Compatible with G9 LED light bulbs.

Pendelleuchte mit Struktur aus Metalldraht mit goldfarbener gebürsteter Ausführung oder mattschwarzer Lackierung. Innerer Diffusor aus Opalglas. Baldachin goldfarben, gebürstet oder mit mattschwarzer Lackierung. Stromkabel schwarz, 200 cm. Einbaubares Leuchtmittel G9 mit LED.

Suspension avec structure en tube rond métallique finition en or brossé ou peint en noir mat. Diffuseur interne en verre opalin. Rosace en or brossé ou peinte en noir mat. Câble d'alimentation noir 200 cm. Possibilité d'installer 1 ampoule LED G9.



CODE	1744.319.Black	1744.319.Gold
COLOR	● Black	● Gold

### LIGHT SOURCE

Source G9 LED | Power 1 x max 10w  
Max bulb size: Ø15xH80mm



# WIRE

## TABLE

Lampada da tavolo con struttura in tondino metallico finitura oro spazzolato o nero opaco. Diffusore interno in vetro opalino. Cavo di alimentazione nero 150 cm. Lampadina installabile G9 a LED dimmerabile.

Table lamp with metal rod frame, in brushed gold or matte black finish. Internal opal glass diffuser. Black 150 cm power supply cord. Compatible with dimmable G9 LED light bulbs.

Tischleuchte mit Struktur aus Metalldraht mit goldfarbener gebürsteter oder mattschwarzer Ausführung. Innerer Diffusor aus Opalglas. Stromkabel schwarz, 150 cm. Einbaubares Leuchtmittel G9 mit LED, dimmbar.

Lampe de table avec structure en tube rond métallique finition en or brossé ou noir mat. Diffuseur interne en verre opalin. Câble d'alimentation noir 150 cm. Possibilité d'installer 1 ampoule LED G9 dimmable.

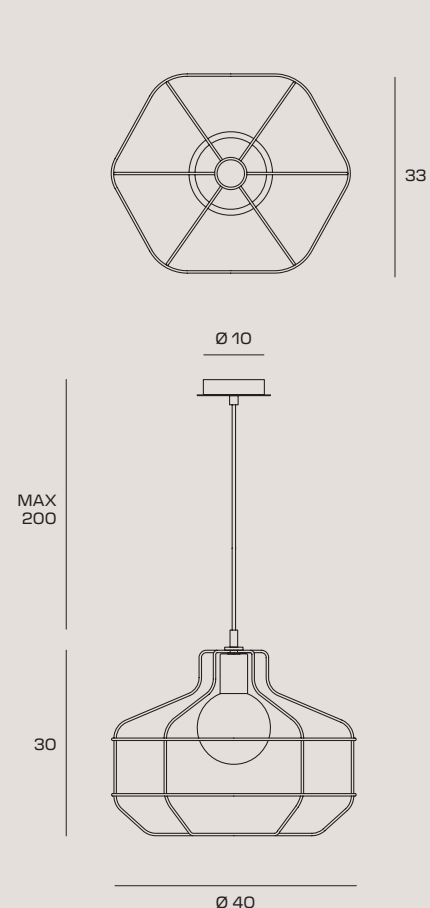
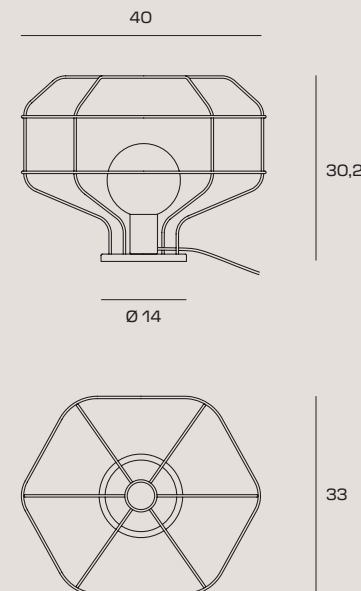

CODE	1744.315.Black	1744.315.Gold
COLOR	● Black	● Gold

### LIGHT SOURCE

Source G9 LED DIMMABLE | Power 1 x max 10w  
Max bulb size: Ø15xH80mm





## DOM

L'armonia dei contrasti, l'equilibrio dell'asimmetria. In Dom vive un dialogo ortogonale tra i diversi elementi, contraddistinto dal gioco tra il posizionamento randomico delle sfere trasparenti che proteggono il punto luce e il rigore della struttura in ottone spazzolato che le sostiene. La leggerezza visiva di Dom, capace di scandire lo spazio in modo discreto e connotante allo stesso tempo, caratterizza ogni sua declinazione.

The harmony of contrasts, the balance of asymmetry.

In Dom lives an orthogonal dialogue between the different elements, characterised by the interplay between the random positioning of the transparent spheres protecting the spotlight, and the rigour of the brushed brass structure supporting them. Dom's visual lightness, capable of scanning the space in a discreet yet connotative manner characterises every one of its declinations.

Die Harmonie der Kontraste, das Gleichgewicht der Asymmetrie. In Dom gibt es einen orthogonalen Dialog zwischen den verschiedenen Elementen, der durch das Wechselspiel zwischen der zufälligen Positionierung der transparenten Kugeln, die den Lichtpunkt schützen, und der Strenge der gebürsteten Messingstruktur, die sie trägt, gekennzeichnet ist. Die visuelle Leichtigkeit von Dom, die den Raum auf eine diskrete und zugleich aussagekräftige Weise abtastet, kennzeichnet jede ihrer Deklinationen.

L'harmonie des contrastes, l'équilibre de l'asymétrie. Dom établit entre les différents éléments un dialogue orthogonal, caractérisé par l'interaction entre la disposition aléatoire des sphères transparentes qui protègent les points lumineux et la rigueur de la structure en laiton brossé qui les soutient. La légèreté visuelle de Dom, qui balaie l'espace d'une manière à la fois discrète et chargée de signification, caractérise chacune de ses déclinaisons.



# DOM

SUSPENSION





# DOM

TABLE





# DOM

TABLE



# DOM

WALL LAMP





# DOM

WALL LAMP





# DOM

CEILING LAMP



# DOM

## CEILING LAMP

Lampada da parete/soffitto a 5 luci  
in vetro borosilicato trasparente  
e cilindro satinato.  
Montatura in ottone spazzolato.

5-light wall/ceiling lamp made of  
transparent borosilicate glass  
and satin-finish cylinder.  
Brushed brass support.

Wand-/Deckenleuchte mit  
5 Lichtern aus transparentem  
Borosilikatglas und satiniertem Zylinder.  
Gestell aus gebürstetem Messing.

Applique ou plafonnier à 5 point lumineux  
en verre borosilicate transparent  
et cylindre satiné.  
Monture en laiton brossé.

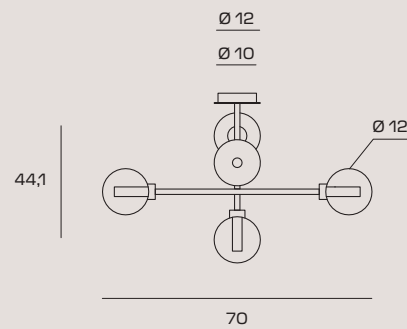
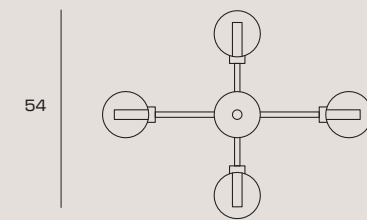

# DOM

## CEILING LAMP

Lampada da parete/soffitto a 6 luci  
in vetro borosilicato trasparente  
e cilindro satinato.  
Montatura in ottone spazzolato.

6-light wall/ceiling lamp made of  
transparent borosilicate glass  
and satin-finish cylinder.  
Brushed brass support.

Wand-/Deckenleuchte mit  
6 Lichtern aus transparentem  
Borosilikatglas und satiniertem Zylinder.  
Gestell aus gebürstetem Messing.

Applique ou plafonnier à 6 point lumineux  
en verre borosilicate transparent  
et cylindre satiné.  
Monture en laiton brossé.

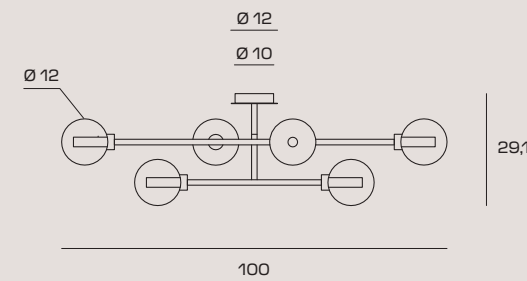
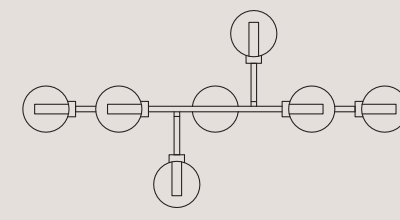

CODE	1744.287
COLOR	● Brushed Gold

### LIGHT SOURCE

Source G9 LED | Power 5 x max 28w  
Max bulb size: Ø20xH70mm



CODE	1744.286
COLOR	● Brushed Gold

### LIGHT SOURCE

Source G9 LED | Power 6 x max 28w  
Max bulb size: Ø20xH70mm



# DOM

## SUSPENSION

Lampada a sospensione a 7 luci in vetro borosilicato trasparente e cilindro satinato. Montatura in ottone spazzolato. Possibilità di utilizzare i tubi di cm 40 e cm 50.

7-light suspension lamp made of transparent borosilicate glass and satin-finish cylinder. Brushed brass support. Option to use 40 or 50 cm pipes.

Hängeleuchte mit 7 Lichtern aus transparentem Borosilikatglas und satiniertem Zylinder. Gestell aus gebürstetem Messing. Möglichkeit der Verwendung von 40 cm und 50 cm langen Röhren.

Suspension à 7 points lumineux en verre borosilicate transparent et cylindre satiné. Monture en laiton brossé. Possibilité d'utiliser les tubes de 40 et 50 cm.

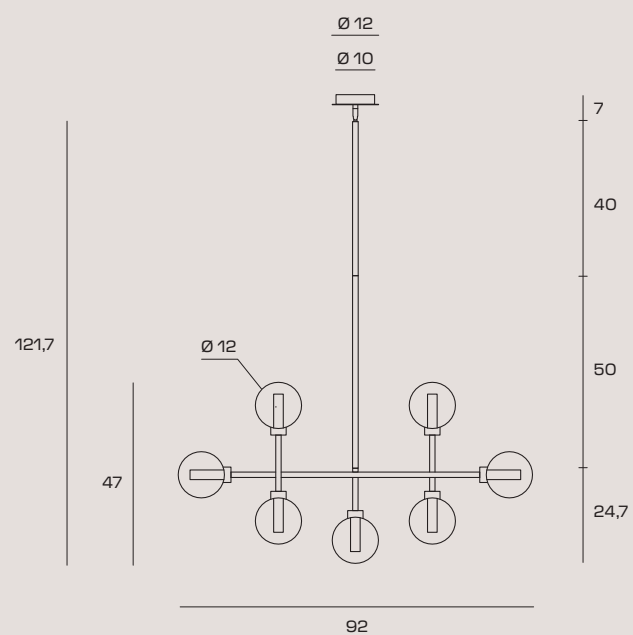
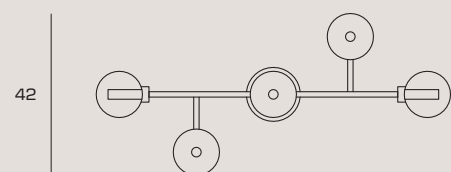

CODE	1744.285
COLOR	● Brushed Gold

### LIGHT SOURCE

Source G9 LED | Power 7 x max 28w  
Max bulb size: Ø20xH70mm



# DOM

## SUSPENSION

Lampada a sospensione a 9 luci in vetro borosilicato trasparente e cilindro satinato. Montatura in ottone spazzolato. Possibilità di utilizzare i tubi di cm 40 e cm 50.

9-light suspension lamp made of transparent borosilicate glass and satin-finish cylinder. Brushed brass support. Option to use 40 or 50 cm pipes.

Hängeleuchte mit 9 Lichtern aus transparentem Borosilikatglas und satiniertem Zylinder. Gestell aus gebürstetem Messing. Möglichkeit der Verwendung von 40 cm und 50 cm langen Röhren.

Suspension à 9 points lumineux en verre borosilicate transparent et cylindre satiné. Monture en laiton brossé. Possibilité d'utiliser les tubes de 40 et 50 cm.

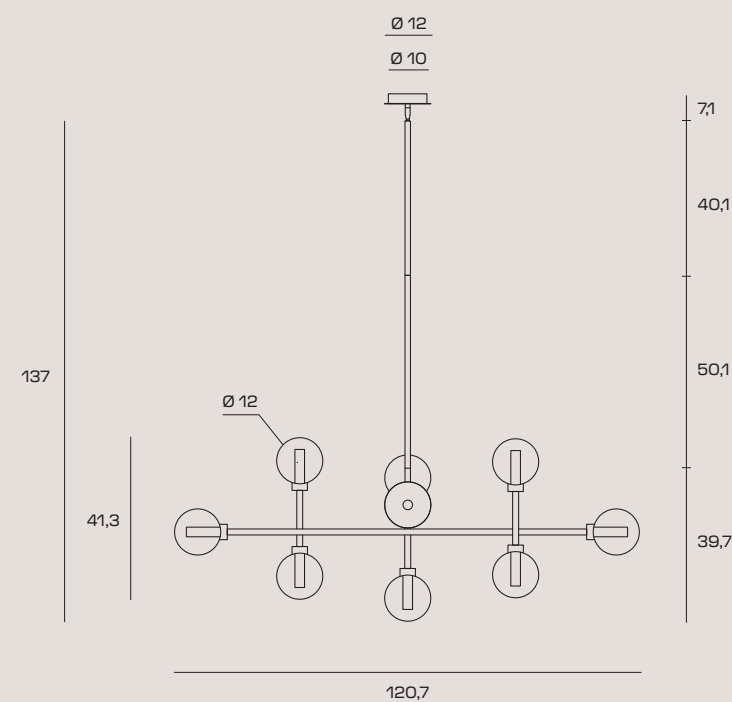
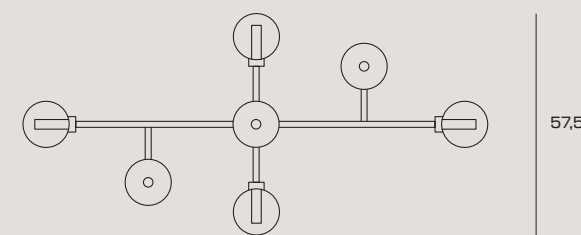

CODE	1744.284
COLOR	● Brushed Gold

### LIGHT SOURCE

Source G9 LED | Power 9 x max 28w  
Max bulb size: Ø20xH70mm



# DOM

## TABLE

Lampada da tavolo a 1 luce  
in vetro borosilicato trasparente  
e cilindro satinato.  
Montatura in ottone spazzolato  
Cavo di alimentazione  
dotato di dimmer.

1-light table lamp made of  
transparent borosilicate glass  
and satin-finish cylinder.  
Brushed brass support  
Power supply cord with dimmer.

Tischleuchte mit 1 Licht  
aus transparentem Borosilikatglas  
und satiniertem Zylinder.  
Gestell aus gebürstetem Messing  
Stromkabel mit Dimmer.

Lampe de table 1 point lumineux  
en verre borosilicate transparent  
et cylindre satiné.  
Monture en laiton brossé  
Câble d'alimentation  
avec variateur.

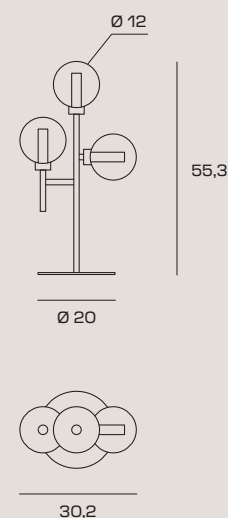
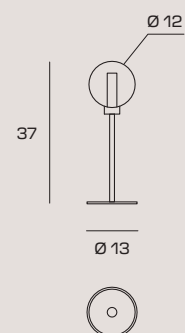

# DOM

## TABLE

Lampada da tavolo a 3 luci  
in vetro borosilicato trasparente  
e cilindro satinato.  
Montatura in ottone spazzolato  
Cavo di alimentazione  
dotato di dimmer.

3-light table lamp made of  
transparent borosilicate glass  
and satin-finish cylinder.  
Brushed brass support  
Power supply cord with dimmer.

Tischleuchte mit 3 Lichtern  
aus transparentem Borosilikatglas  
und satiniertem Zylinder.  
Gestell aus gebürstetem Messing  
Stromkabel mit Dimmer.

Lampe de table 3 point lumineux  
en verre borosilicate transparent  
et cylindre satiné.  
Monture en laiton brossé  
Câble d'alimentation  
avec variateur.

CODE	1744.291
COLOR	● Brushed Gold

### LIGHT SOURCE

Source G9 LED DIMMABLE | Power 1 x max 10w  
Max bulb size: Ø20xH70mm



CODE	1744.292
COLOR	● Brushed Gold

### LIGHT SOURCE

Source G9 LED DIMMABLE | Power 3 x max 10w  
Max bulb size: Ø20xH70mm



# DOM

## WALL LAMP

Lampada da parete a 1 luce  
in vetro borosilicato trasparente  
e cilindro satinato.  
Montatura in ottone spazzolato.

1-light wall lamp made of  
transparent borosilicate glass  
and satin-finish cylinder.  
Brushed brass support.

Wandleuchte mit 1 Licht  
aus transparentem Borosilikatglas  
und satiniertem Zylinder.  
Gestell aus gebürstetem Messing.

Applique 1 point lumineux  
en verre borosilicate transparent  
et cylindre satiné.  
Monture en laiton brossé.

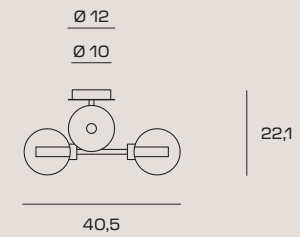
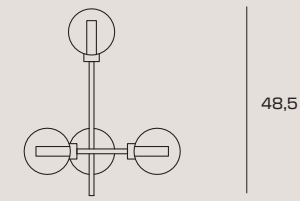
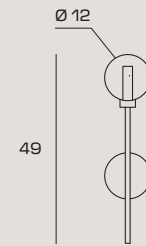

# DOM

## WALL LAMP

Lampada da parete a 3 luci  
in vetro borosilicato trasparente  
e cilindro satinato.  
Montatura in ottone spazzolato.

3-light wall lamp made of  
transparent borosilicate glass  
and satin-finish cylinder.  
Brushed brass support.

Wandleuchte mit 3 Lichtern  
aus transparentem Borosilikatglas  
und satiniertem Zylinder.  
Gestell aus gebürstetem Messing.

Applique 3 points lumineux  
en verre borosilicate transparent  
et cylindre satiné.  
Monture en laiton brossé.

CODE	1744.289
COLOR	 Brushed Gold

### LIGHT SOURCE

 Source G9 LED | Power 1 x max 28w  
Max bulb size: Ø20xH70mm



CODE	1744.290
COLOR	 Brushed Gold

### LIGHT SOURCE

 Source G9 LED | Power 3 x max 28w  
Max bulb size: Ø20xH70mm





# CAMELY

## CAMELY

La primavera che nasce e porta alla luce i suoi frutti più belli. Camely presenta diverse ramificazioni in oro spazzolato, sulle quali sbocciano in modo asimmetrico i fiori: bolle trasparenti che emanano una luce calda e diffusa. L'alternanza degli elementi cilindrici e le possibili configurazioni di ramificazione danno vita ad un vero elemento d'arredo.

Spring comes and brings along its nicer fruits. Camely features several brushed gold branches, with flowers blossoming on them asymmetrically, into transparent bubbles emanating a warm, diffused light. The alternating cylinder elements and the possible branch configurations create a true designer element.

Der frühling, der einzug hält und seine schönsten früchte ans licht bringt. Camely weist verschiedene goldfarbene gebürstete verästelungen auf, auf denen auf asymmetrische weise die blumen erblühen: transparente blasen, die ein warmes und diffuses licht abgeben. Der wechsel der zylindrischen elemente und die möglichen konfigurationen der verästelung lassen ein echtes dekoratives element entstehen.

Le printemps qui naît et met en lumière ses plus beaux fruits. Camely présente plusieurs ramifications dans la finition en or brossé, sur lesquelles les fleurs s'ouvrent de manière asymétrique : des bulles transparentes qui dégagent une lumière chaude et diffuse. L'alternance des éléments cylindriques et les configurations possibles de ramification donnent naissance à un véritable élément de décoration.

# CAMELY

SUSPENSION



# CAMELY

SUSPENSION



# CAMELY

TABLE



# CAMELY

TABLE







# CAMELY

WALL LAMP



# CAMELY

WALL LAMP





# CAMELY

CEILING LAMP



# CAMELY

FLOOR LAMP





# CAMELY

## FLOOR LAMP

Lampada da terra con diffusori in vetro borosilicato trasparente. Diffusori interni in vetro borosilicato sabbiato. Struttura in metallo con finitura oro spazzolato. Base in metallo finitura oro spazzolato. Lampadine installabili 3 x G9 LED. Cavo di alimentazione nero 150 cm dimmerabile.

Floor lamp with transparent borosilicate glass diffusers. Internal frosted borosilicate glass diffusers. Metal frame with a brushed gold finish. Brushed gold metal base. Compatible with 3 x G9 LED light bulbs. Black 150 cm dimmable power supply cord.

Stehleuchte mit Diffusoren aus transparentem Borosilikatglas. Innere Diffusoren aus sandgestrahltem Borosilikatglas. Metallstruktur mit goldfarbener gebürsteter Ausführung. Sockel aus Metall mit goldfarbener gebürsteter Ausführung. Einbaubare Leuchtmittel 3 x G9 mit LED. Stromkabel schwarz, 150 cm, dimmbar.

Lampadaire avec diffuseurs en verre borosilicate transparent. Diffuseurs internes en verre borosilicate sablé. Structure en métal avec finition en or brossé. Base en métal, finition en or brossé. Possibilité d'installer 3 ampoules LED G9. Câble d'alimentation noir 150 cm dimmable.

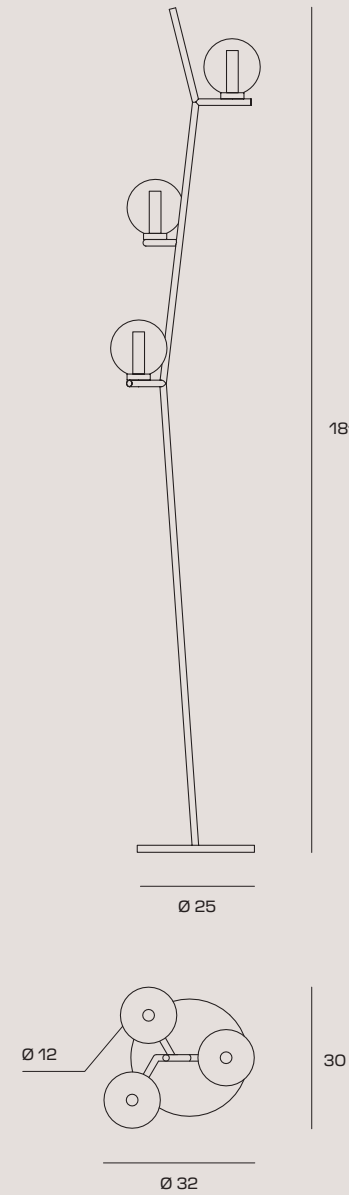

CODE 1744.304

COLOR ● Brushed Gold

### LIGHT SOURCE

 Source G9 LED DIMMABLE | Power 3 x max 10w  
Max bulb size: Ø18xH68mm



# CAMELY

## SUSPENSION

Lampada a sospensione con diffusori in vetro borosilicato trasparente. Diffusori interni in vetro borosilicato sabbato. Struttura in metallo con finitura oro spazzolato. Rosone in metallo finitura oro spazzolato. Lampadine installabili 3 x G9 LED.

Suspension lamp with transparent borosilicate glass diffusers. Internal frosted borosilicate glass diffusers. Metal frame with a brushed gold finish. Brushed gold metal ceiling canopy. Compatible with 3 x G9 LED light bulbs.

Pendelleuchte mit Diffusoren aus transparentem Borosilikatglas. Innere Diffusoren aus sandgestrahltem Borosilikatglas. Metallstruktur mit goldfarbener gebürsteter Ausführung. Baldachin aus Metall mit goldfarbener gebürsteter Ausführung. Einbaubare Leuchtmittel 3 x G9 mit LED.

Suspension avec diffuseurs en verre borosilicate transparent. Diffuseurs internes en verre borosilicate sablé. Structure en métal avec finition en or brossé. Rosace en métal finition en or brossé. Possibilité d'installer 3 ampoules LED G9.

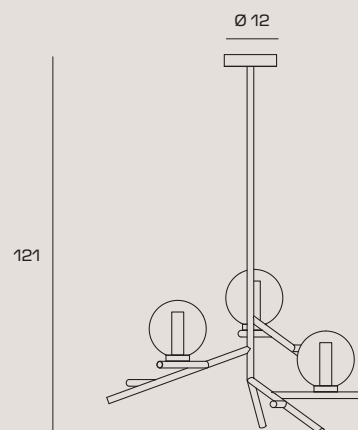
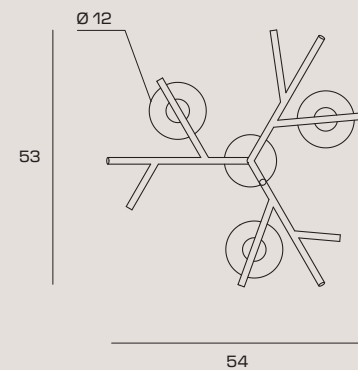

CODE 1744.307

COLOR  Brushed Gold

### LIGHT SOURCE

 Source G9 LED | Power 3 x max 10w  
Max bulb size: Ø18xH68mm



# CAMELY

## SUSPENSION

Lampada a sospensione con diffusori in vetro borosilicato trasparente. Diffusori interni in vetro borosilicato sabbato. Struttura in metallo con finitura oro spazzolato. Rosone in metallo finitura oro spazzolato. Lampadine installabili 6 x G9 LED.

Suspension lamp with transparent borosilicate glass diffusers. Internal frosted borosilicate glass diffusers. Metal frame with a brushed gold finish. Brushed gold metal ceiling canopy. Compatible with 6 x G9 LED light bulbs.

Pendelleuchte mit Diffusoren aus transparentem Borosilikatglas. Innere Diffusoren aus sandgestrahltem Borosilikatglas. Metallstruktur mit goldfarbener gebürsteter Ausführung. Baldachin aus Metall mit goldfarbener gebürsteter Ausführung. Einbaubare Leuchtmittel 6 x G9 mit LED.

Suspension avec diffuseurs en verre borosilicate transparent. Diffuseurs internes en verre borosilicate sablé. Structure en métal avec finition en or brossé. Rosace en métal finition en or brossé. Possibilité d'installer 6 ampoules LED G9.

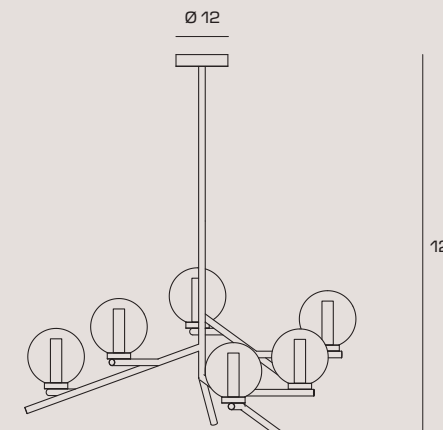
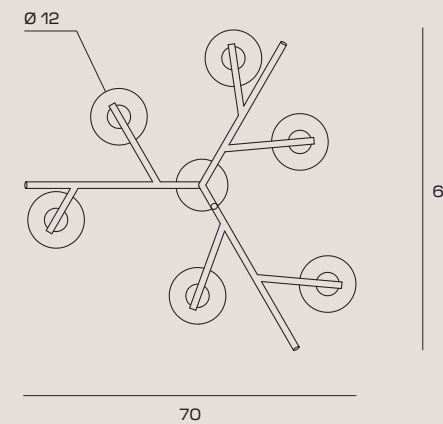

CODE 1744.308

COLOR  Brushed Gold

### LIGHT SOURCE

 Source G9 LED | Power 6 x max 10w  
Max bulb size: Ø18xH68mm

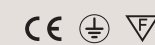

# CAMELY

## TABLE

Lampada da tavolo con diffusore in vetro borosilicato trasparente. Diffusore interno in vetro borosilicato sabbiato. Struttura in metallo con finitura oro spazzolato. Base in metallo finitura oro spazzolato. Lampadina installabile 1 x G9 LED dimmerabile. Cavo di alimentazione nero 150 cm. dotato di dimmer.

Table lamp with transparent borosilicate glass diffuser. Internal frosted borosilicate glass diffuser. Brushed gold metal ceiling canopy. Brushed gold metal base. Compatible with 1 x dimmable G9 LED light bulb. Black 150 cm power supply cord with dimmer.

Tischleuchte mit Diffusor aus transparentem Borosilikatglas. Innerer Diffusor aus sandgestrahltem Borosilikatglas. Metallstruktur mit goldfarbener gebürsteter Ausführung. Sockel aus Metall mit goldfarbener gebürsteter Ausführung. Einbaubares Leuchtmittel 1 x G9 mit LED, dimmbar. Stromkabel schwarz, 150 cm. mit Dimmer.

Lampe de table avec diffuseur en verre borosilicate transparent. Diffuseur interne en verre borosilicate sablé. Structure en métal avec finition en or brossé. Base en métal, finition en or brossé. Possibilité d'installer 1 ampoule LED G9 dimmable. Câble d'alimentation noir 150 cm. avec variateur.

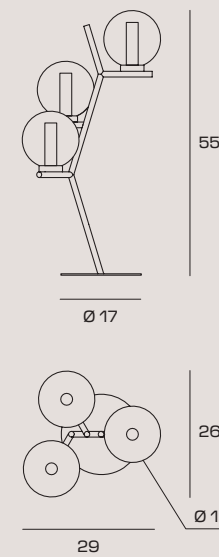

# CAMELY

## TABLE

Lampada da tavolo con diffusori in vetro borosilicato trasparente. Diffusori interni in vetro borosilicato sabbiato. Struttura in metallo con finitura oro spazzolato. Base in metallo finitura oro spazzolato. Lampadine installabili 3 x G9 LED dimmerabile. Cavo di alimentazione nero 150 cm. dotato di dimmer.

Table lamp with transparent borosilicate glass diffusers. Internal frosted borosilicate glass diffusers. Metal frame with a brushed gold finish. Brushed gold metal base. Compatible with 3 x dimmable G9 LED light bulbs. Black 150 cm power supply cord with dimmer.

Tischleuchte mit Diffusoren aus transparentem Borosilikatglas. Innere Diffusoren aus sandgestrahltem Borosilikatglas. Metallstruktur mit goldfarbener gebürsteter Ausführung. Sockel aus Metall mit goldfarbener gebürsteter Ausführung. Einbaubare Leuchtmittel 3 x G9 mit LED, dimmbar. Stromkabel schwarz, 150 cm. mit Dimmer.

Lampe de table avec diffuseurs en verre borosilicate transparent. Diffuseurs internes en verre borosilicate sablé. Structure en métal avec finition en or brossé. Base en métal, finition en or brossé. Possibilité d'installer 3 ampoules LED G9 dimmable. Câble d'alimentation noir 150 cm. avec variateur.

CODE	1744.305
COLOR	 Brushed Gold

### LIGHT SOURCE

 Source G9 LED DIMMABLE | Power 1 x max 10w  
Max bulb size: Ø18xH68mm



CODE	1744.306
COLOR	 Brushed Gold

### LIGHT SOURCE

 Source G9 LED DIMMABLE | Power 3 x max 10w  
Max bulb size: Ø18xH68mm



# CAMELY

## WALL LAMP

Lampada a parete con diffusore in vetro borosilicato trasparente. Diffusore interno in vetro borosilicato sabbato. Struttura in metallo con finitura oro spazzolato. Rosone in finitura oro spazzolato. Lampadina installabile 1 x G9 LED.

Wall lamp with transparent borosilicate glass diffuser. Internal frosted borosilicate glass diffuser. Brushed gold metal metal base. Brushed gold ceiling canopy. Compatible with 1 x G9 LED light bulb.

Wandleuchte mit Diffusor aus transparentem Borosilikatglas. Innerer Diffusor aus sandgestrahltem Borosilikatglas. Metallstruktur mit goldfarbener gebürsteter Ausführung. Baldachin mit goldfarbener gebürsteter Ausführung. Einbaubares Leuchtmittel 1 x G9 mit LED.

Applique avec diffuseur en verre borosilicate transparent. Diffuseur interne en verre borosilicate sablé. Structure en métal avec finition en or brossé. Rosace finition en or brossé. Possibilité d'installer 1 ampoule LED G9.

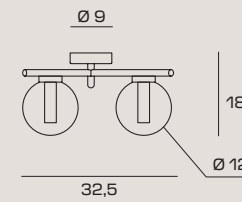
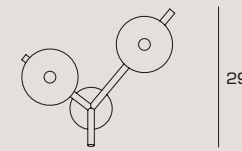
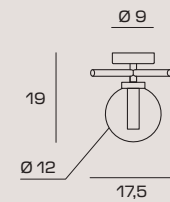

# CAMELY

## WALL LAMP

Lampada a parete con diffusori in vetro borosilicato trasparente. Diffusori interni in vetro borosilicato sabbato. Struttura in metallo con finitura oro spazzolato. Rosone in finitura oro spazzolato. Lampadine installabili 2 x G9 LED.

Wall lamp with transparent borosilicate glass diffusers. Internal frosted borosilicate glass diffusers. Brushed gold metal base. Brushed gold ceiling canopy. Compatible with 2 x G9 LED light bulbs.

Wandleuchte mit Diffusoren aus transparentem Borosilikatglas. Innere Diffusoren aus sandgestrahltem Borosilikatglas. Metallstruktur mit goldfarbener gebürsteter Ausführung. Baldachin mit goldfarbener gebürsteter Ausführung. Einbaubare Leuchtmittel 2 x G9 mit LED.

Applique avec diffuseurs en verre borosilicate transparent. Diffuseurs internes en verre borosilicate sablé. Structure en métal avec finition en or brossé. Rosace finition en or brossé. Possibilité d'installer 2 ampoules LED G9.

CODE	1744.302
COLOR	 Brushed Gold

### LIGHT SOURCE

 Source G9 LED | Power 1 x max 10w  
Max bulb size: Ø18xH68mm



CODE	1744.303
COLOR	 Brushed Gold

### LIGHT SOURCE

 Source G9 LED | Power 2 x max 10w  
Max bulb size: Ø18xH68mm

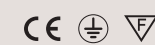

# CAMELY

## CEILING LAMP

Lampada a soffitto con diffusori in vetro borosilicato trasparente. Diffusori interni in vetro borosilicato sabbiato. Struttura in metallo con finitura oro spazzolato. Rosone in metallo finitura oro spazzolato. Lampadine installabili 3 x G9 LED.

Ceiling lamp with transparent borosilicate glass diffusers. Internal frosted borosilicate glass diffusers. Brushed gold metal base. Brushed gold metal ceiling canopy. Compatible with 3 x G9 LED light bulbs.

Deckenleuchte mit Diffusoren aus transparentem Borosilikatglas. Innere Diffusoren aus sandgestrahltem Borosilikatglas. Metallstruktur mit goldfarbener gebürsteter Ausführung. Baldachin aus Metall mit goldfarbener gebürsteter Ausführung. Einbaubare Leuchtmittel 3 x G9 mit LED.

Plafonnier avec diffuseurs en verre borosilicate transparent. Diffuseurs internes en verre borosilicate sablé. Structure en métal avec finition en or brossé. Rosace en métal finition en or brossé. Possibilité d'installer 3 ampoules LED G9.

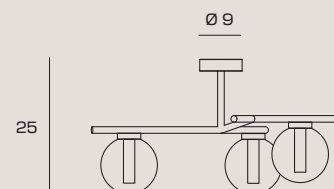
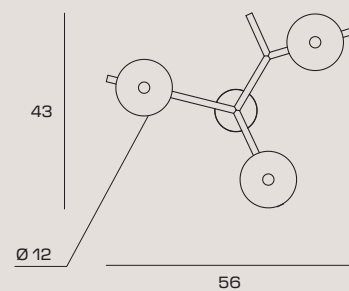

# CAMELY

## CEILING LAMP

Lampada a soffitto con diffusori in vetro borosilicato trasparente. Diffusori interni in vetro borosilicato sabbiato. Struttura in metallo con finitura oro spazzolato. Rosone in metallo finitura oro spazzolato. Lampadine installabili 5 x G9 LED.

Ceiling lamp with transparent borosilicate glass diffusers. Internal frosted borosilicate glass diffusers. Metal frame with a brushed gold finish. Brushed gold metal ceiling canopy. Compatible with 5 x G9 LED light bulbs.

Deckenleuchte mit Diffusoren aus transparentem Borosilikatglas. Innere Diffusoren aus sandgestrahltem Borosilikatglas. Metallstruktur mit goldfarbener gebürsteter Ausführung. Baldachin aus Metall mit goldfarbener gebürsteter Ausführung. Einbaubare Leuchtmittel 5 x G9 mit LED.

Plafonnier avec diffuseurs en verre borosilicate transparent. Diffuseurs internes en verre borosilicate sablé. Structure en métal avec finition en or brossé. Rosace en métal finition en or brossé. Possibilité d'installer 5 ampoules LED G9.

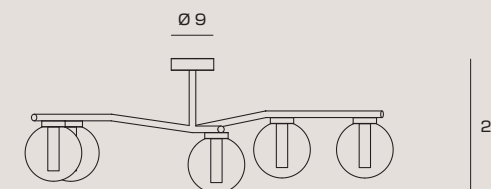
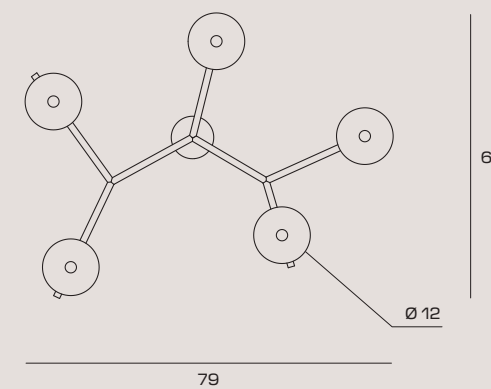

CODE	1744.309
COLOR	 Brushed Gold

### LIGHT SOURCE

 Source G9 LED | Power 3 x max 10w  
Max bulb size: Ø18xH68mm



CODE	1744.310
COLOR	 Brushed Gold

### LIGHT SOURCE

 Source G9 LED | Power 5 x max 10w  
Max bulb size: Ø18xH68mm





# MIKADO

WINNER



## MIKADO

Flessibilità compositiva.  
Mikado incarna l'essenza stessa della libertà espressiva e creativa: la possibilità di orientare a piacimento le bacchette permette di dare origine a geometrie ortogonali o dinamiche, esplorando soluzioni più rigide o più fluide. L'equilibrio tra la struttura in metallo verniciato e i diffusori è completamente sganciato da ogni vincolo formale. Questa estrema autonomia è la ragione per cui Mikado è stata premiata con il Good Design Award.

Compositional flexibility.  
Mikado embodies the very essence of expressive and creative freedom: the ability to direct the rods freely gives rise to orthogonal or dynamic geometries, exploring more rigid or more fluid solutions. The balance between the painted metal structure and the diffusers is completely free from any formal constraints. This extreme autonomy is the reason why Mikado was awarded the Good Design Award.

Kompositorische Flexibilität.  
Mikado verkörpert die Essenz expressiver und kreativer Freiheit: Die Möglichkeit, die Stäbe nach Belieben auszurichten, erlaubt die Schaffung orthogonaler oder dynamischer Geometrien und die Erforschung starrer oder fließender Lösungen. Das Gleichgewicht zwischen der lackierten Metallstruktur und den Diffusoren ist völlig frei von jeglichen formalen Zwängen. Diese extreme Autonomie ist der Grund, warum Mikado mit dem Good Design Award ausgezeichnet wurde.

Flexibilité de la composition.  
Mikado incarne l'essence même de la liberté d'expression et de création : la capacité d'orienter à volonté les baguettes permet de créer des géométries orthogonales ou dynamiques et d'explorer des solutions rigides ou fluides. L'équilibre entre la structure en métal peint et les diffuseurs élimine toute contrainte formelle. Cette autonomie extrême a valu à Mikado le prix Good design.

# MIKADO

WALL | CEILING LAMP

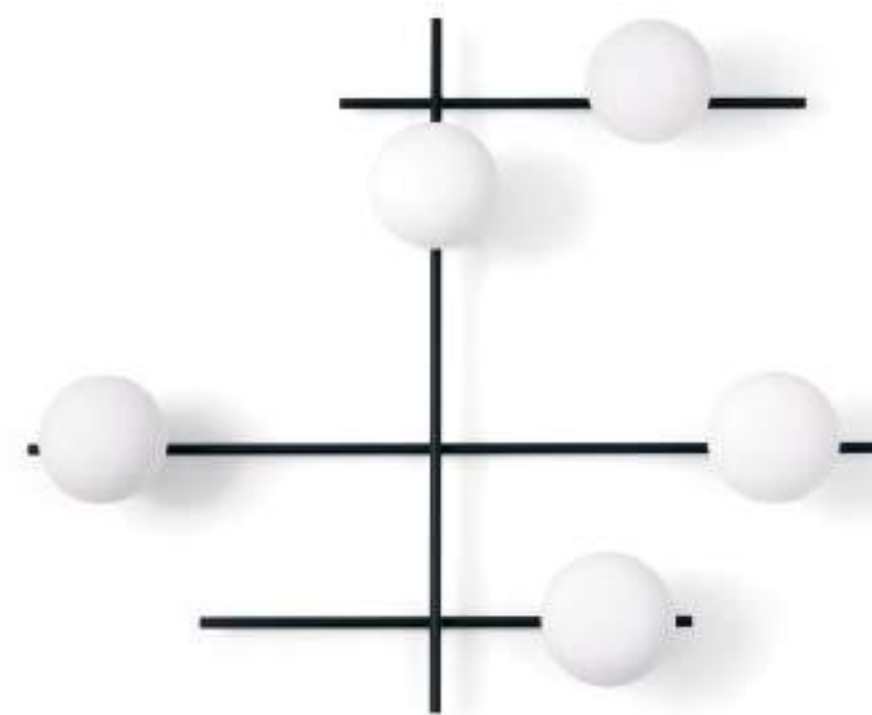
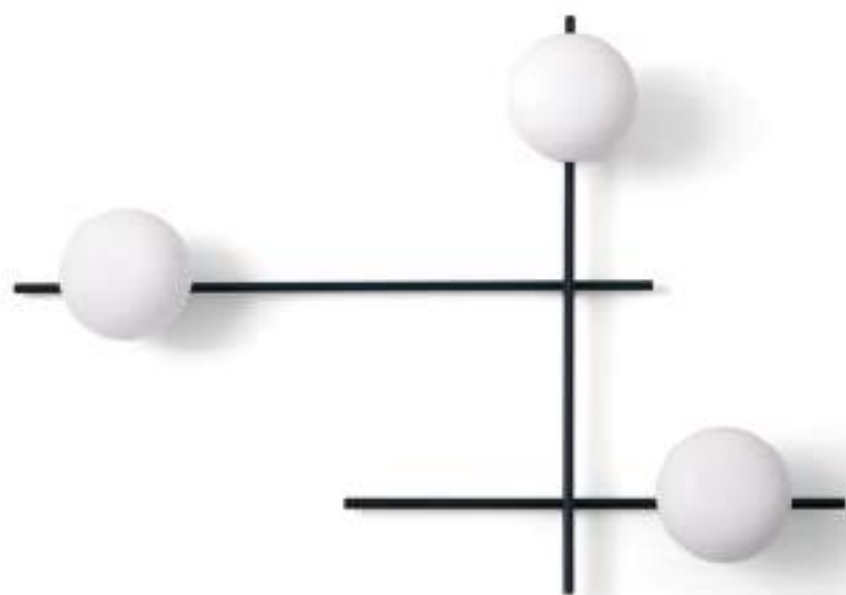
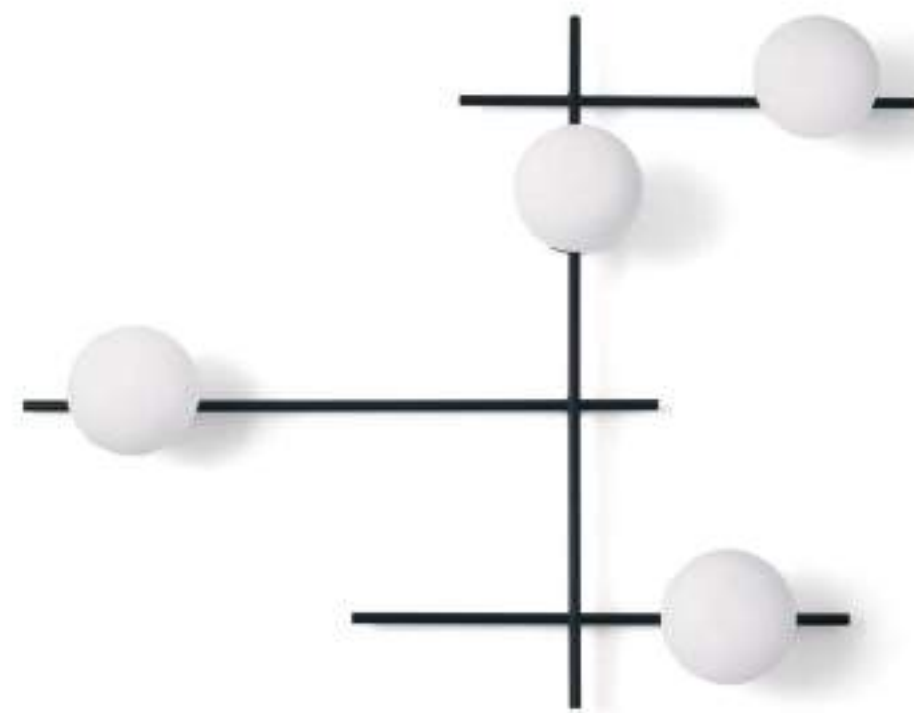
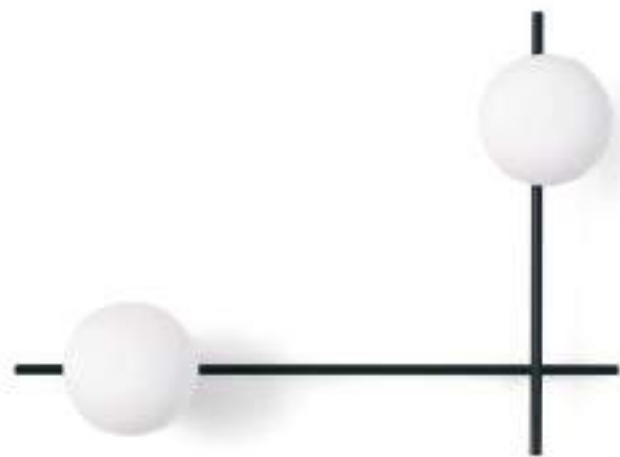



# MIKADO

WALL | CEILING LAMP

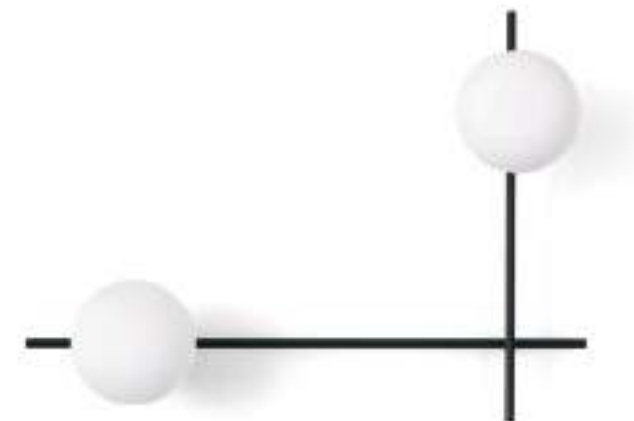



# MIKADO

WALL | CEILING LAMP

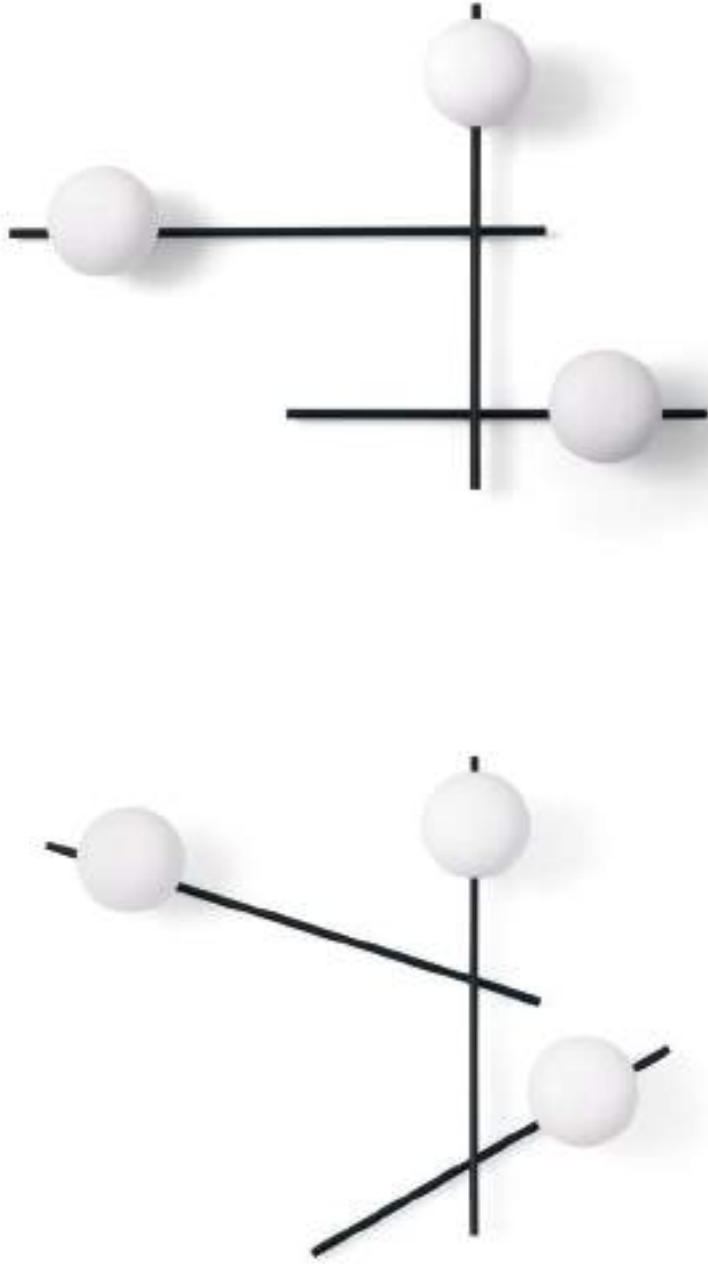



# MIKADO

WALL | CEILING LAMP

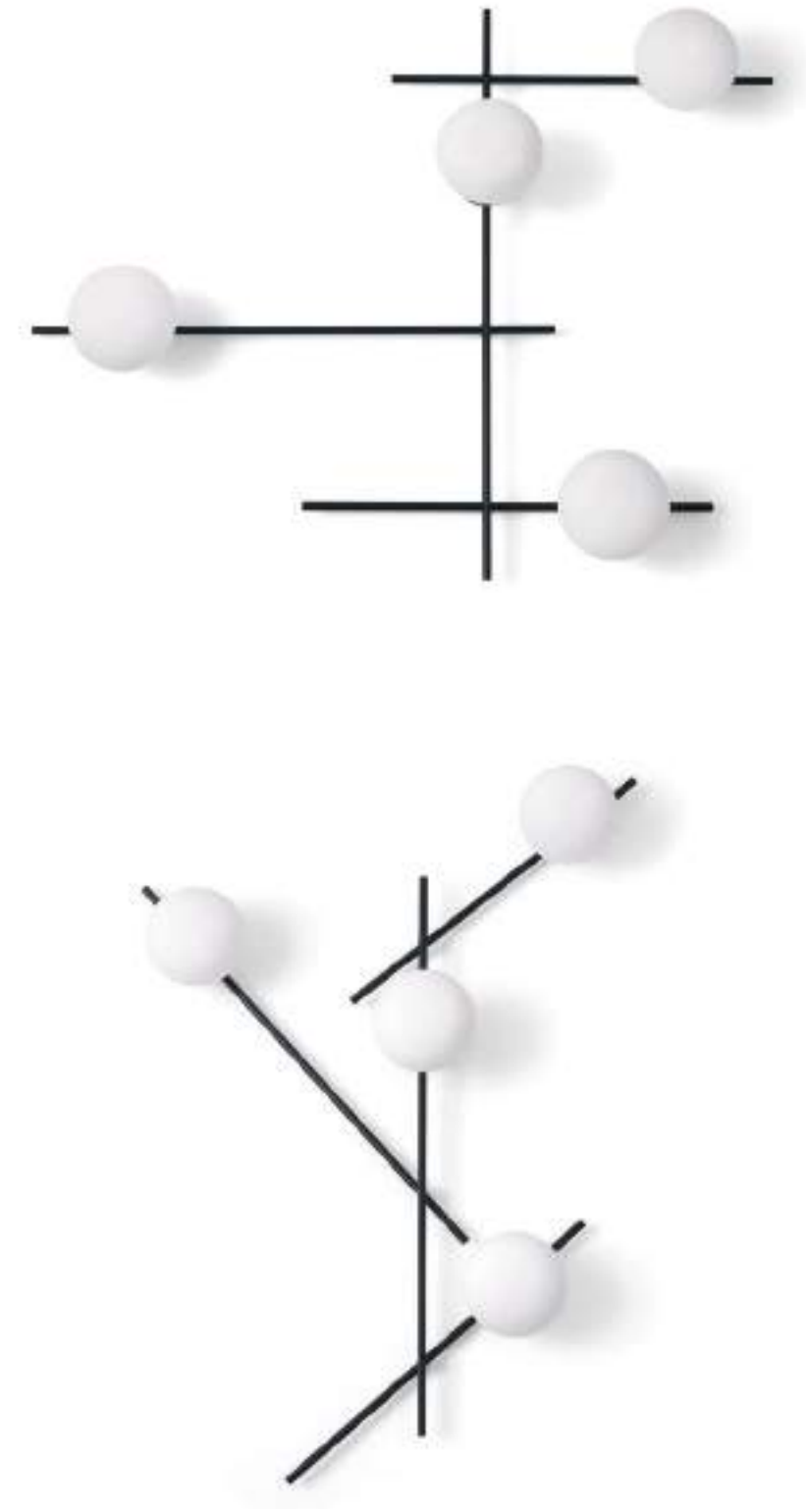

# MIKADO

WALL | CEILING LAMP

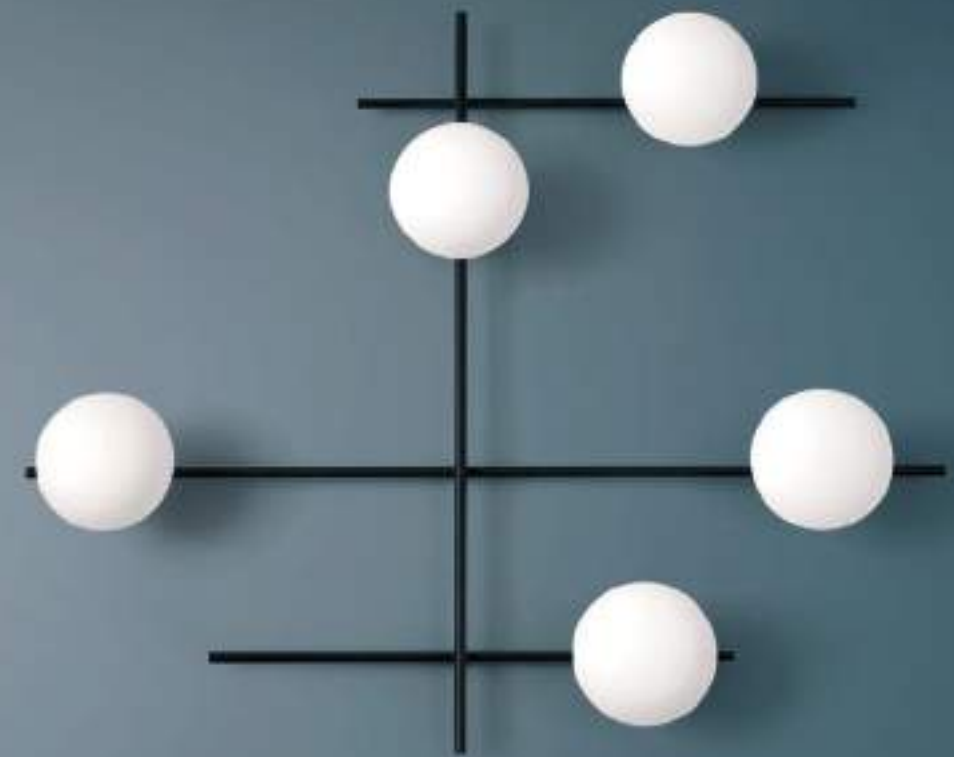
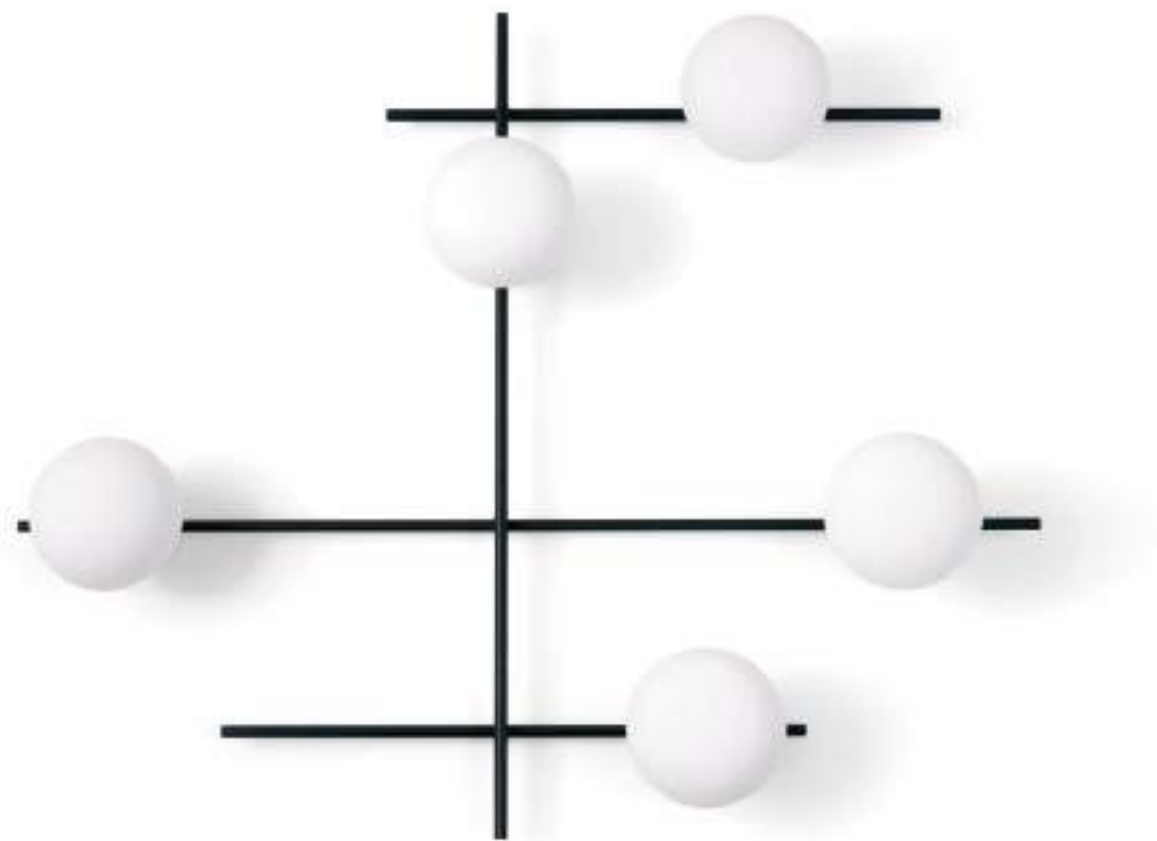

# MIKADO

WALL | CEILING LAMP

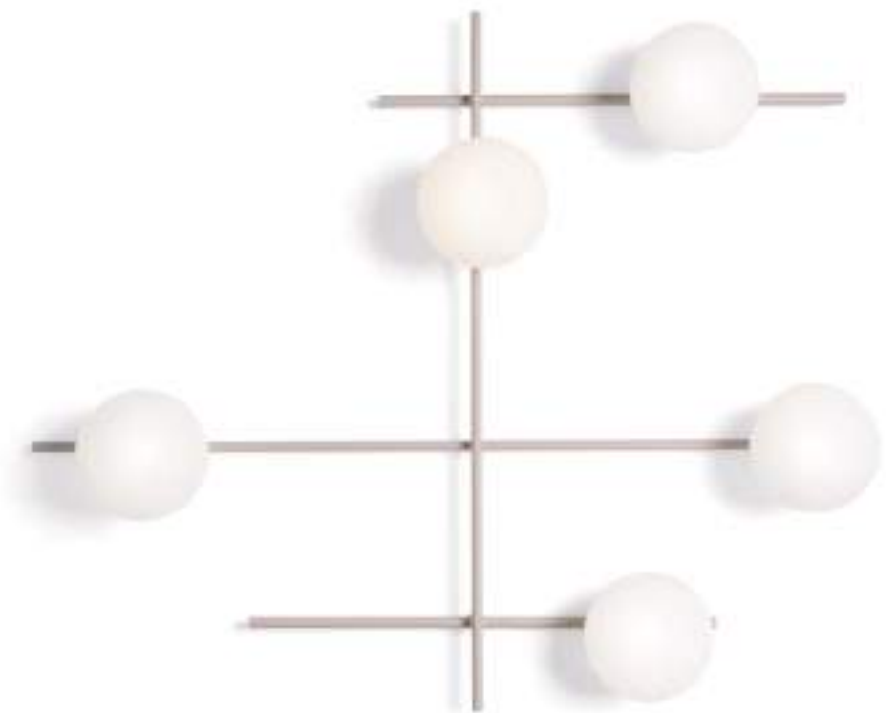
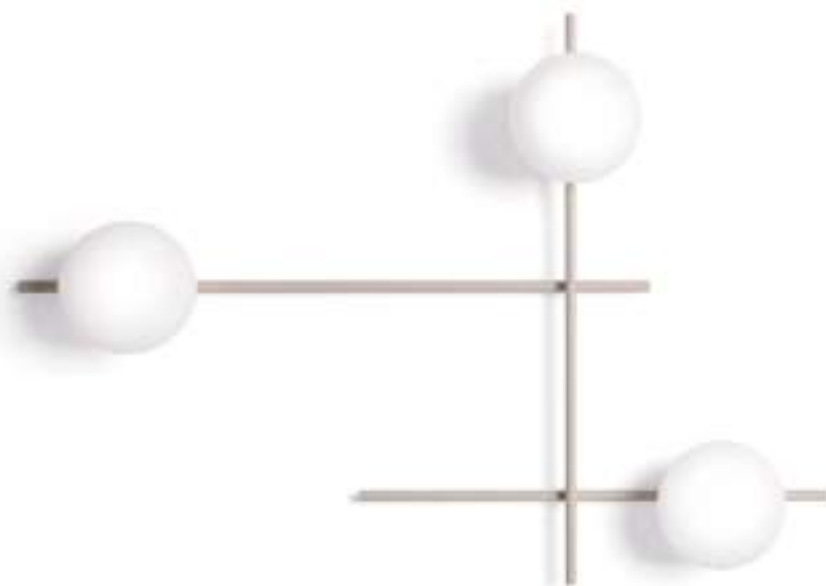
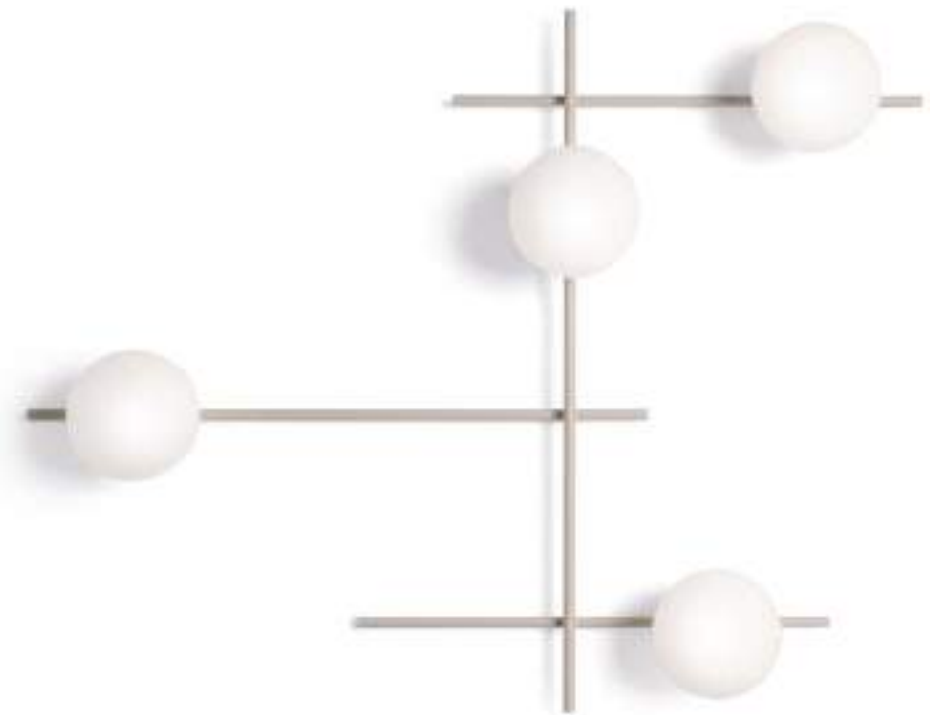

# MIKADO

WALL | CEILING LAMP



# MIKADO

WALL | CEILING LAMP





# MIKADO

WALL | CEILING LAMP

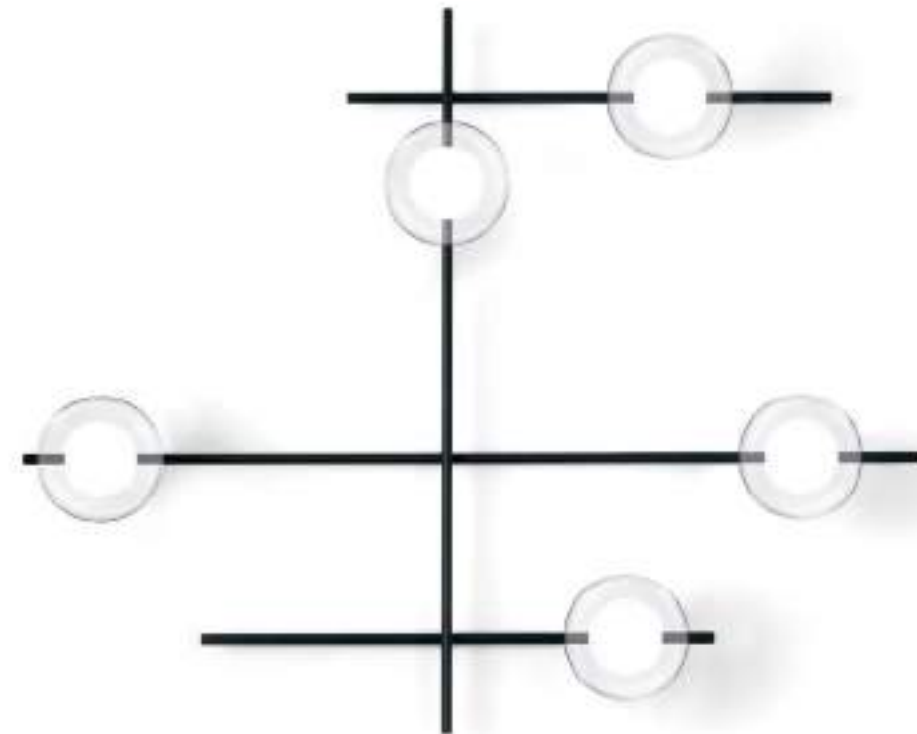
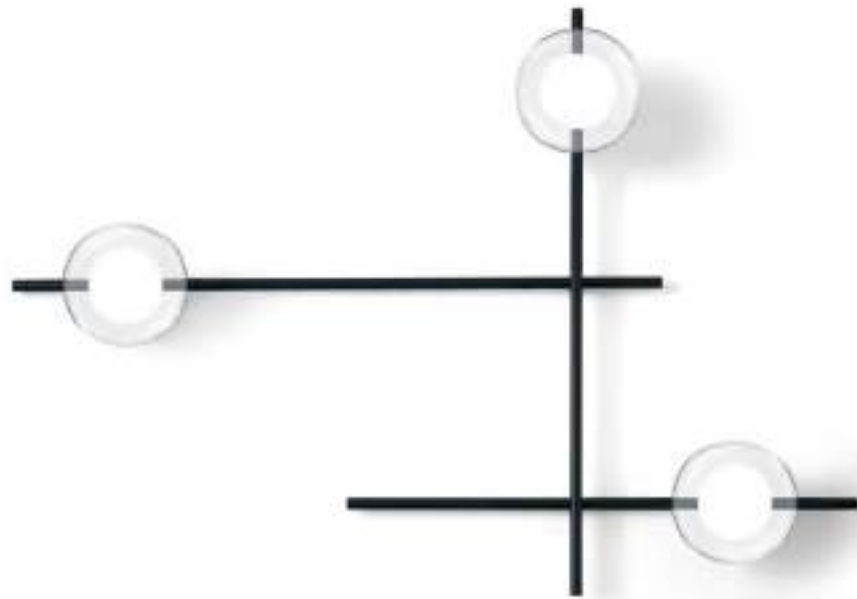
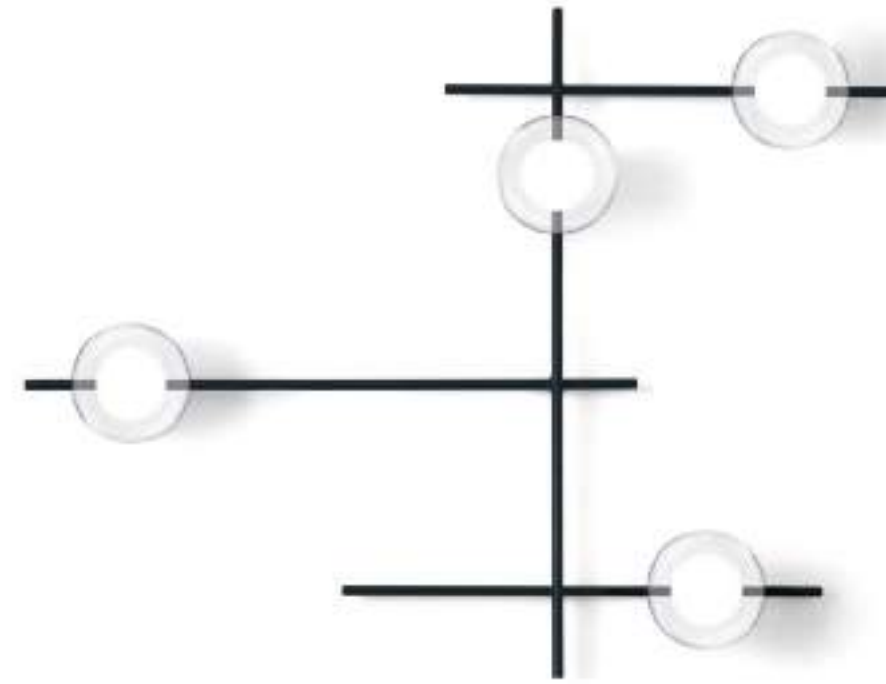
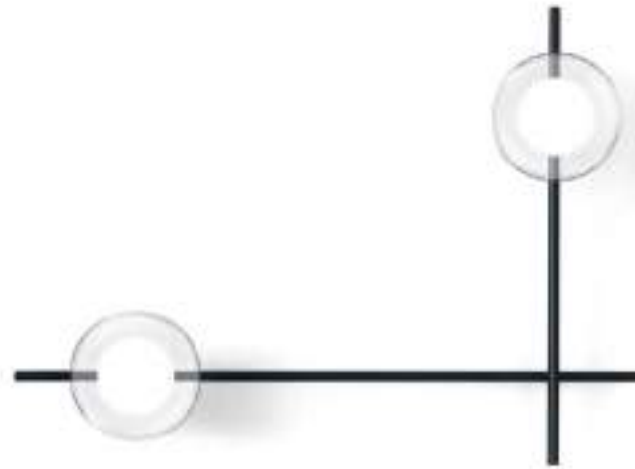



# MIKADO

WALL | CEILING LAMP





# MIKADO

WALL | CEILING LAMP

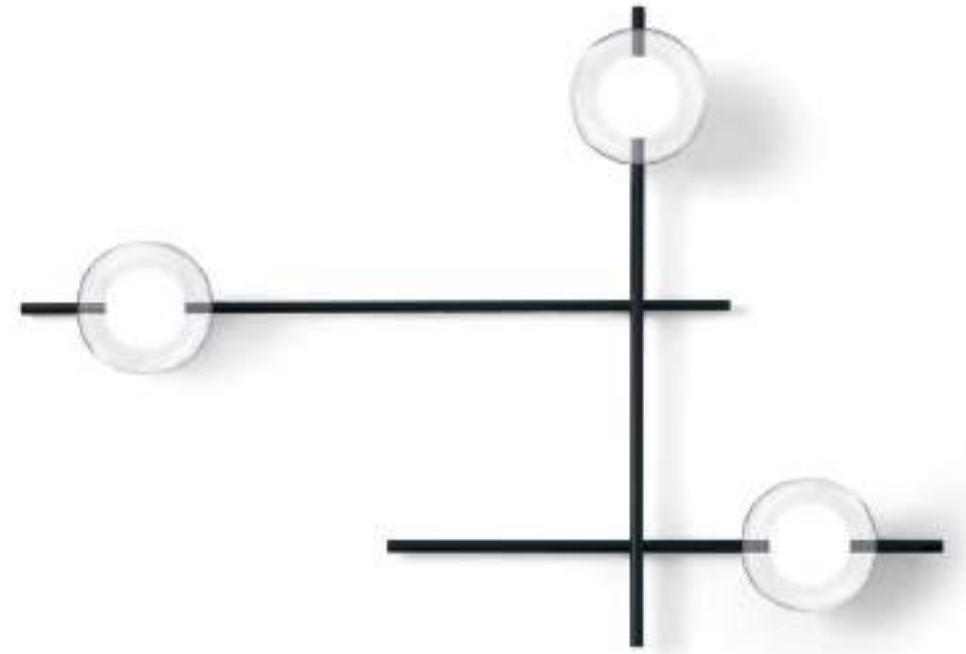

# MIKADO

WALL | CEILING LAMP





# MIKADO

WALL | CEILING LAMP

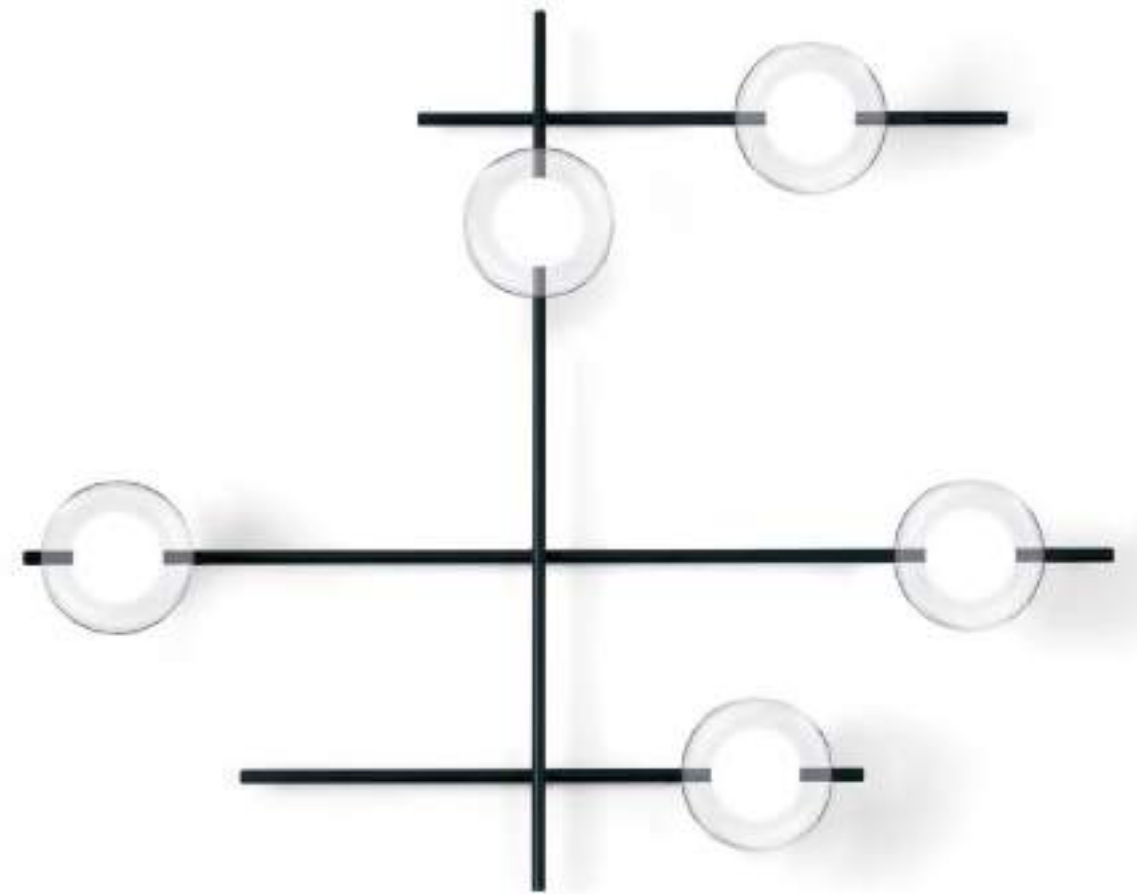

# MIKADO

WALL | CEILING LAMP



# MIKADO

WALL | CEILING LAMP

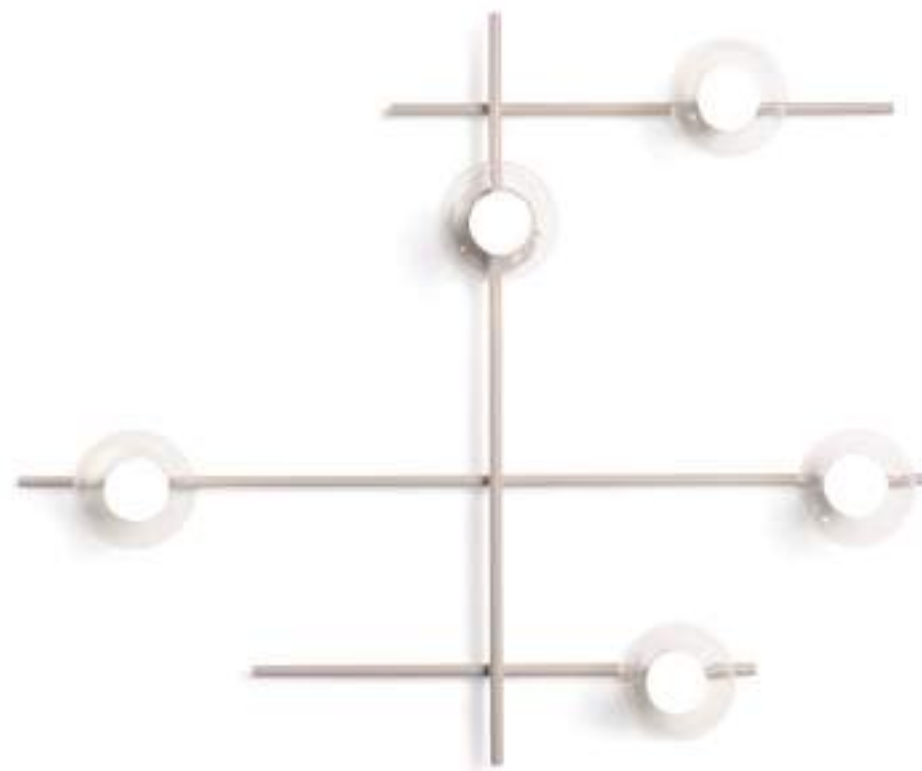
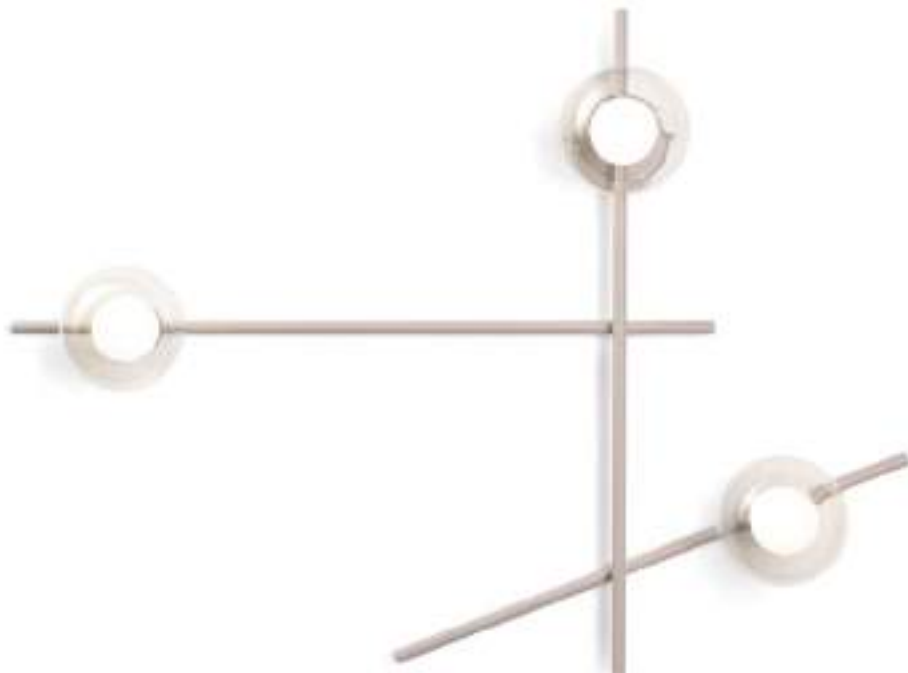

# MIKADO

WALL | CEILING LAMP



# MIKADO

WALL | CEILING LAMP

Lampada da parete o soffitto con montatura in metallo verniciato a polvere nero o cipria opaco. Diffusore in vetro soffiato bianco latte diametro 12cm o diffusore in vetro borosilicato trasparente esterno e satinato interno, diametro 12 cm. La rotazione dei bracci secondari consente di scegliere la posizione preferita.

Wall or ceiling lamp with matt black or powder-coated metal mount. Milk-white blown glass diffuser (12 cm diameter) or diffuser with transparent borosilicate glass on the outside and satin-finished on the inside (12 cm diameter). The rotation of the secondary arms allows choosing the preferred position.

Wand- oder Deckenleuchte mit mattschwarzem oder cipriafarbenem pulverbeschichtetem Metallgestell. Diffusor aus mundgeblasenem milchweißem Glas, Durchmesser 12 cm, oder Diffusor aus Borosilikatglas, außen transparent und innen satiniert, Durchmesser 12 cm. Die Drehung der Sekundärarme ermöglicht es, die bevorzugte Position zu wählen.

Applique ou plafonnier avec monture en métal revêtu de peinture poudre noire ou rose poudré mat. Diffuseur en verre soufflé blanc laiteux diamètre 12 cm ou diffuseur en verre borosilicate, extérieur transparent et intérieur satiné, diamètre 12 cm. La rotation des bras secondaires permet de modifier la position.

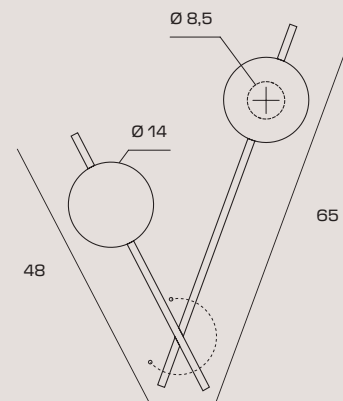

- + Uscita cavo elettrico
- + Power Supply
- + Brennstelle
- + Sortie de câble électrique

# MIKADO

WALL | CEILING LAMP

Lampada da parete o soffitto con montatura in metallo verniciato a polvere nero o cipria opaco. Diffusore in vetro soffiato bianco latte diametro 12cm o diffusore in vetro borosilicato trasparente esterno e satinato interno, diametro 12 cm. La rotazione dei bracci secondari consente di scegliere la posizione preferita.

Wall or ceiling lamp with matt black or powder-coated metal mount. Milk-white blown glass diffuser (12 cm diameter) or diffuser with transparent borosilicate glass on the outside and satin-finished on the inside (12 cm diameter). The rotation of the secondary arms allows choosing the preferred position.

Wand- oder Deckenleuchte mit mattschwarzem oder cipriafarbenem pulverbeschichtetem Metallgestell. Diffusor aus mundgeblasenem milchweißem Glas, Durchmesser 12 cm, oder Diffusor aus Borosilikatglas, außen transparent und innen satiniert, Durchmesser 12 cm. Die Drehung der Sekundärarme ermöglicht es, die bevorzugte Position zu wählen.

Applique ou plafonnier avec monture en métal revêtu de peinture poudre noire ou rose poudré mat. Diffuseur en verre soufflé blanc laiteux diamètre 12 cm ou diffuseur en verre borosilicate, extérieur transparent et intérieur satiné, diamètre 12 cm. La rotation des bras secondaires permet de modifier la position.

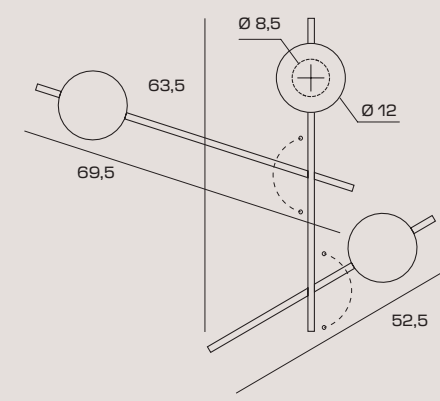

- + Uscita cavo elettrico
- + Power Supply
- + Brennstelle
- + Sortie de câble électrique

WINNER



WINNER



CODE	1744.175	1744.218	1744.372	1744.376
GLASS	● White	○ Transparent	● White	○ Transparent
COLOR	● Black	● Black	● Pink Powder	● Pink Powder

LIGHT SOURCE

Source G9 LED | Power 2 x max 10w  
Max bulb size: Ø20xH60mm



CODE	1744.176	1744.219	1744.373	1744.377
GLASS	● White	○ Transparent	● White	○ Transparent
COLOR	● Black	● Black	● Pink Powder	● Pink Powder

LIGHT SOURCE

Source G9 LED | Power 3 x max 10w  
Max bulb size: Ø20xH60mm



# MIKADO

WALL | CEILING LAMP

Lampada da parete o soffitto con montatura in metallo verniciato a polvere nero o cipria opaco. Diffusore in vetro soffiato bianco latte diametro 12cm o diffusore in vetro borosilicato trasparente esterno e satinato interno, diametro 12 cm. La rotazione dei bracci secondari consente di scegliere la posizione preferita.

Wall or ceiling lamp with matt black or powder-coated metal mount. Milk-white blown glass diffuser (12 cm diameter) or diffuser with transparent borosilicate glass on the outside and satin-finished on the inside (12 cm diameter). The rotation of the secondary arms allows choosing the preferred position.

Wand- oder Deckenleuchte mit mattschwarzem oder cipriafarbenem pulverbeschichtetem Metallgestell. Diffusor aus mundgeblasenem milchweißem Glas, Durchmesser 12 cm, oder Diffusor aus Borosilikatglas, außen transparent und innen satiniert, Durchmesser 12 cm. Die Drehung der Sekundärarme ermöglicht es, die bevorzugte Position zu wählen.

Applique ou plafonnier avec monture en métal revêtu de peinture poudre noire ou rose poudré mat. Diffuseur en verre soufflé blanc laiteux diamètre 12 cm ou diffuseur en verre borosilicate, extérieur transparent et intérieur satiné, diamètre 12 cm. La rotation des bras secondaires permet de modifier la position.

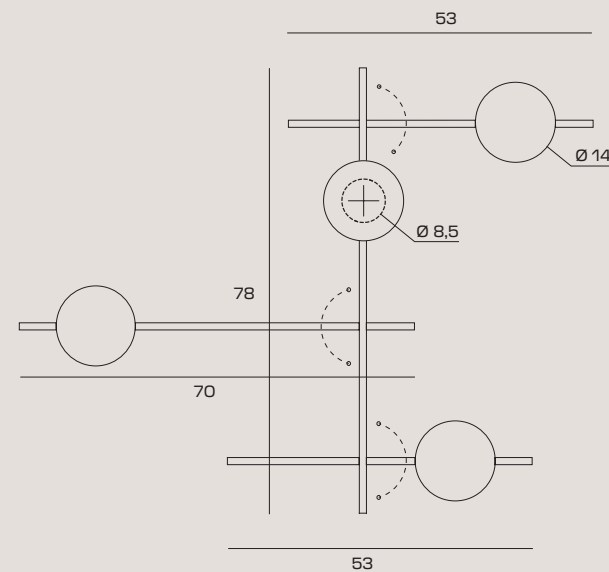

- + Uscita cavo elettrico
- + Power Supply
- + Brennstelle
- + Sortie de câble électrique

# MIKADO

WALL | CEILING LAMP

Lampada da parete o soffitto con montatura in metallo verniciato a polvere nero o cipria opaco. Diffusore in vetro soffiato bianco latte diametro 12cm o diffusore in vetro borosilicato trasparente esterno e satinato interno, diametro 12 cm. La rotazione dei bracci secondari consente di scegliere la posizione preferita.

Wall or ceiling lamp with matt black or powder-coated metal mount. Milk-white blown glass diffuser (12 cm diameter) or diffuser with transparent borosilicate glass on the outside and satin-finished on the inside (12 cm diameter). The rotation of the secondary arms allows choosing the preferred position.

Wand- oder Deckenleuchte mit mattschwarzem oder cipriafarbenem pulverbeschichtetem Metallgestell. Diffusor aus mundgeblasenem milchweißem Glas, Durchmesser 12 cm, oder Diffusor aus Borosilikatglas, außen transparent und innen satiniert, Durchmesser 12 cm. Die Drehung der Sekundärarme ermöglicht es, die bevorzugte Position zu wählen.

Applique ou plafonnier avec monture en métal revêtu de peinture poudre noire ou rose poudré mat. Diffuseur en verre soufflé blanc laiteux diamètre 12 cm ou diffuseur en verre borosilicate, extérieur transparent et intérieur satiné, diamètre 12 cm. La rotation des bras secondaires permet de modifier la position.

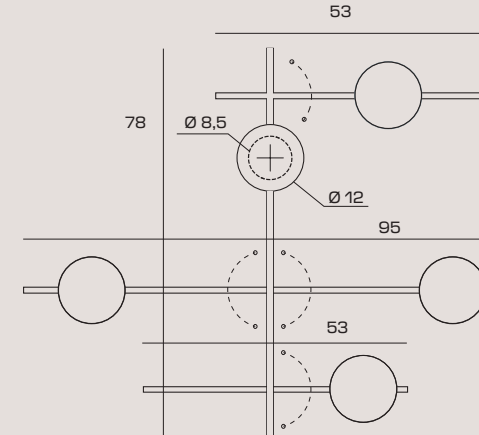

- + Uscita cavo elettrico
- + Power Supply
- + Brennstelle
- + Sortie de câble électrique

WINNER



CODE	1744.177	1744.220	1744.374	1744.378
GLASS	● White	○ Transparent	● White	○ Transparent
COLOR	● Black	● Black	● Pink Powder	● Pink Powder

LIGHT SOURCE

Source G9 LED | Power 4 x max 10w  
Max bulb size: Ø20xH60mm



WINNER



CODE	1744.178	1744.221	1744.375	1744.379
GLASS	● White	○ Transparent	● White	○ Transparent
COLOR	● Black	● Black	● Pink Powder	● Pink Powder

LIGHT SOURCE

Source G9 LED | Power 5 x max 10w  
Max bulb size: Ø20xH60mm





FUJI

## FUJI

L'attimo fugace dell'eruzione cristallizzato in una nuvola ovale in vetro opalino. Fuji onora l'imponenza e la maestosità del noto monte giapponese in una configurazione essenziale: uno o più bottoni puntiformi sorretti da una base conica grigio tortora. Nelle diverse versioni - singola e multipla - Fuji mantiene inalterato il proprio linguaggio minimale, un punto di forza che le consente di essere inserita con estrema facilità in qualsivoglia ambiente.

The fleeting moment of an eruption, crystallised in an oval cloud of opaline glass. Fuji honours the grandeur and majesty of the well-known Japanese mountain in an essential configuration: one or more pin-point buttons supported by a Dove grey conical base. In different versions - single and multiple - Fuji retains its minimalist language, a strength that enables it to be included in any environment with extreme ease.

Der flüchtige Moment des Ausbruchs kristallisiert in einer ovalen Wolke aus opalem Glas. Fuji ehrt die Erhabenheit und Majestät des bekannten japanischen Berges in einer wesentlichen Konfiguration: ein oder mehrere Punktknöpfe getragen von einem taupefarbenen konischen Sockel. In ihren verschiedenen Versionen - einzeln und mehrfach - behält Fuji seine minimalistische Sprache bei, eine Stärke, die es erlaubt, sich leicht in jede Umgebung einzufügen.

L'instant fugace de l'éruption, cristallisé dans un nuage ovale de verre opalin. Fuji rend hommage à la grandeur et à la majesté du célèbre volcan japonais avec une configuration essentielle : un ou plusieurs boutons ponctuels, soutenus par une base conique gris tourterelle. En différentes versions - simple et multiple - Fuji maintient son langage épuré, un point fort qui lui permet de s'intégrer très facilement à tous les espaces.



# FUJI

TABLE



# FUJI

WALL / CEILING LAMP



# FUJI

WALL / CEILING LAMP





# FUJI

WALL / CEILING LAMP



# FUJI

WALL / CEILING LAMP





# FUJI

## TABLE

Lampada da tavolo con diffusore in vetro soffiato bianco latte diametro cm 16. Montatura realizzata in metallo verniciato grigio tortora. Cavo di alimentazione con dimmer. Lampadina GX53.

Table lamp with milk white blown glass lampshade, diameter: 16 cm. Dove grey painted metal support. Power supply cord with dimmer. Light bulb: GX53.

Tischleuchte mit Diffusor aus geblasenem milchweißem Glas, Durchmesser 16 cm. Taubengrau lackiertes Metallgestell. Netzkabel mit Dimmer. Leuchtmittel GX53.

Lampe de table avec diffuseur en verre soufflé blanc laiteux diamètre 16 cm. Monture en métal peinte gris tourterelle. Câble d'alimentation avec variateur. Ampoule GX53.

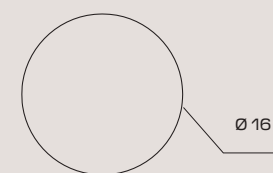
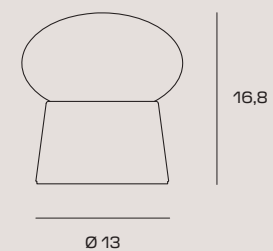

CODE	1744.256
COLOR	● Dove Grey

### LIGHT SOURCE

 Source | GX53 LED DIMMABLE | Power | 1 x max 10w  
Max bulb size: Ø75xH28mm

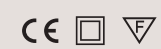

# FUJI

WALL | CEILING LAMP

Lampada da parete o soffitto con diffusore in vetro soffiato bianco latte diametro cm 16. Montatura realizzata in metallo verniciato grigio tortora. Lampadina GX53.

Wall or ceiling lamp with milk white blown glass lampshade, diameter: 16 cm. Dove grey painted metal support. Light bulb: GX53.

Wand- oder Deckenleuchte mit Diffusor aus geblasenem milchweißem Glas, Durchmesser 16 cm. Taubengrau lackiertes Metallgestell. Leuchtmittel GX53.

Applique ou plafonnier avec diffuseur en verre soufflé blanc laiteux diamètre 16 cm. Monture en métal peinte gris tourterelle. Ampoule GX53.

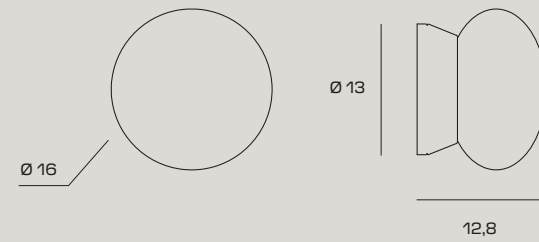

NOT AVAILABLE

CODE 1744.257

COLOR ● Dove Grey

## LIGHT SOURCE



Source | GX53 LED | Power | 1 x max 10w  
Max bulb size: Ø75xH28mm



# FUJI

WALL | CEILING LAMP

Lampada da parete o soffitto con diffusore in vetro soffiato bianco latte diametro cm 16. Montatura realizzata in metallo verniciato grigio tortora. Lampadina GX53.

Wall or ceiling lamp with milk white blown glass lampshade, diameter: 16 cm. Dove grey painted metal support. Light bulb: GX53.

Wand- oder Deckenleuchte mit Diffusor aus geblasenem milchweißem Glas, Durchmesser 16 cm. Taubengrau lackiertes Metallgestell. Leuchtmittel GX53.

Applique ou plafonnier avec diffuseur en verre soufflé blanc laiteux diamètre 16 cm. Monture en métal peinte gris tourterelle. Ampoule GX53.

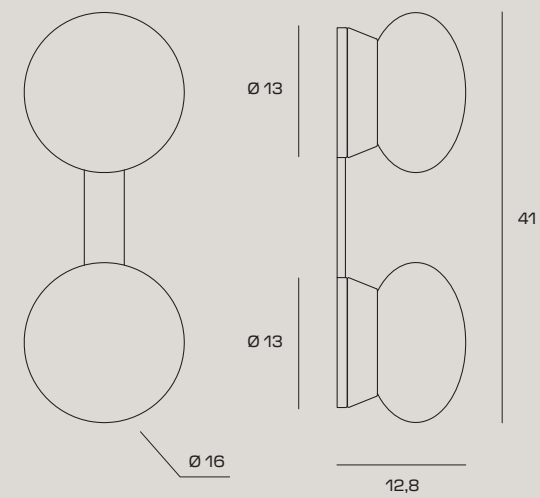

NOT AVAILABLE

CODE 1744.253

COLOR ● Dove Grey

## LIGHT SOURCE



Source | GX53 LED | Power | 2 x max 10w  
Max bulb size: Ø75xH28mm



# FUJI

## WALL | CEILING LAMP

Lampada da parete o soffitto con diffusore in vetro soffiato bianco latte diametro cm 16. Montatura realizzata in metallo verniciato grigio tortora. Lampadina GX53.

Wall or ceiling lamp with milk white blown glass lampshade, diameter: 16 cm. Dove grey painted metal support. Light bulb: GX53.

Wand- oder Deckenleuchte mit Diffusor aus geblasenem milchweißem Glas, Durchmesser 16 cm. Taubengrau lackiertes Metallgestell. Leuchtmittel GX53.

Applique ou plafonnier avec diffuseur en verre soufflé blanc laiteux diamètre 16 cm. Monture en métal peinte gris tourterelle. Ampoule GX53.

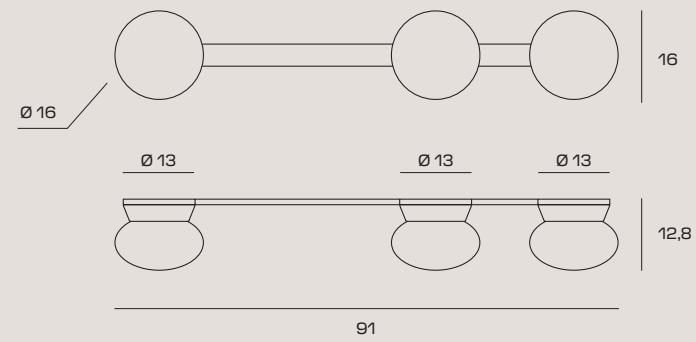

CODE 1744.254

COLOR  Dove Grey

### LIGHT SOURCE



Source | GX53 LED | Power | 3 x max 10w  
Max bulb size: Ø75xH28mm



# FUJI

## WALL | CEILING LAMP

Lampada da parete o soffitto con diffusore in vetro soffiato bianco latte diametro cm 16. Montatura realizzata in metallo verniciato grigio tortora. Lampadina GX53.

Wall or ceiling lamp with milk white blown glass lampshade, diameter: 16 cm. Dove grey painted metal support. Light bulb: GX53.

Wand- oder Deckenleuchte mit Diffusor aus geblasenem milchweißem Glas, Durchmesser 16 cm. Taubengrau lackiertes Metallgestell. Leuchtmittel GX53.

Applique ou plafonnier avec diffuseur en verre soufflé blanc laiteux diamètre 16 cm. Monture en métal peinte gris tourterelle. Ampoule GX53.

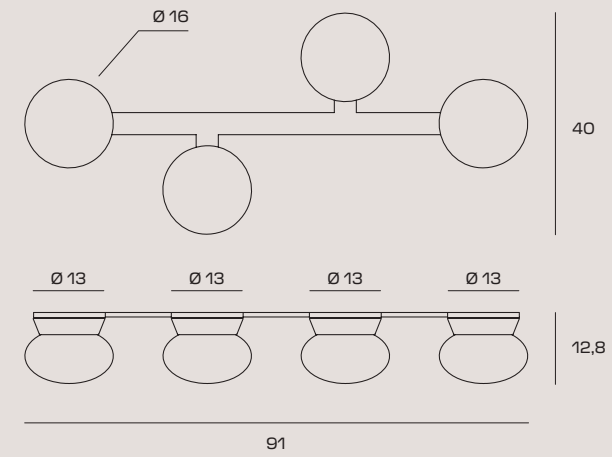

CODE 1744.255

COLOR  Dove Grey

### LIGHT SOURCE



Source | GX53 LED | Power | 4 x max 10w  
Max bulb size: Ø75xH28mm

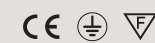



# DROP

## DROP

Una goccia d'acqua pronta a cadere o una lanterna cinese pronta a volare. A seconda dell'applicazione, sospensione o tavolo, Drop cristallizza nella sua forma tondeggiante l'istante che precede il salto nel vuoto, catturandone la sensazione di leggerezza e libertà. La finitura in oro spazzolato eleva la preziosità della lampada, la variante nero opaco ne valorizza il design.

A water Droplet ready to fall, or a chinese lantern about to fly away. Depending on the application, suspension or table lamp, Drop crystallizes in its rounded shape the instant preceding a leap into the unknown, capturing its sensation of lightness and freedom. The brushed gold finish makes this lamp even more precious, while the matte black version emphasizes its design.

Ein wassertropfen, bereit zum hinunterfallen oder eine himmelslaterne bereit zum davonfliegen. je nach anwendung, als pendel- oder tischleuchte, kristallisiert Drop in ihrer gewölbten form den augenblick kurz vor dem sprung ins leere, und fängt dessen gefühl von leichtigkeit und freiheit ein. Die goldfarbene, gebürstete ausführung macht die leuchte noch kostbarer, die variante in mattschwarz unterstreicht ihr design.

Une goutte d'eau prête à tomber ou une lanterne chinoise prête à s'envoler. Qu'il s'agisse de la suspension ou de la lampe de table, Drop cristallise dans sa forme arrondie l'instant qui précède le saut dans le vide, capturant la sensation de légèreté et de liberté. La finition en or brossé élève la valeur de la lampe, la variante noire mate en valorise le design.

# DROP

SUSPENSION



# DROP

TABLE



# DROP

TABLE



# DROP

## SUSPENSION

Lampada a sospensione con struttura e rosone con finitura oro spazzolato oppure verniciata nero opaco. Diffusore in vetro opalino. Cavo di alimentazione nero 200 cm. Lampadina installabile E27 a LED.

Suspension lamp with brushed gold or painted matte black frame and ceiling canopy. Opal glass diffuser. Black 200 cm power supply cord. Compatible with E27 LED light bulbs.

Pendelleuchte mit Struktur und Baldachin mit goldfarbener gebürsteter Ausführung oder mit mattschwarzer Lackierung. Diffusor aus Opalglas. Stromkabel schwarz, 200 cm. Einbaubares Leuchtmittel E27 mit LED.

Suspension avec structure et rosace avec finition en or brossé ou peint en noir mat. Diffuseur en verre opalin. Câble d'alimentation noir 200 cm. Possibilité d'installer 1 ampoule LED E27.



CODE	1744.316.Black	1744.316.Gold
COLOR	● Black	● Gold

### LIGHT SOURCE

Source E27 LED | Power 1 x max 20w  
Max bulb size: Ø75xH240mm



# DROP

## TABLE

Lampada da tavolo con struttura in tubolare metallico finitura oro spazzolato o verniciata nero opaco. Diffusore in vetro opalino. Cavo di alimentazione nero 150 cm. Lampadina installabile E27 a LED dimmerabile.

Table lamp with metal tube frame in brushed gold or painted matte black finish. Opal glass diffuser. Black 150 cm power supply cord. Compatible with dimmable E27 LED light bulbs.

Tischleuchte mit Struktur aus Metallrohr mit goldfarbener gebürsteter Ausführung oder mattschwarzer Lackierung. Diffusor aus Opalglas. Stromkabel schwarz, 150 cm. Einbaubares Leuchtmittel E27 mit LED, dimmbar.

Lampe de table avec structure en tube métallique, finition en or brossé ou peint en noir mat. Diffuseur en verre opalin. Câble d'alimentation noir 150 cm. Possibilité d'installer 1 ampoule LED E27 dimmable.

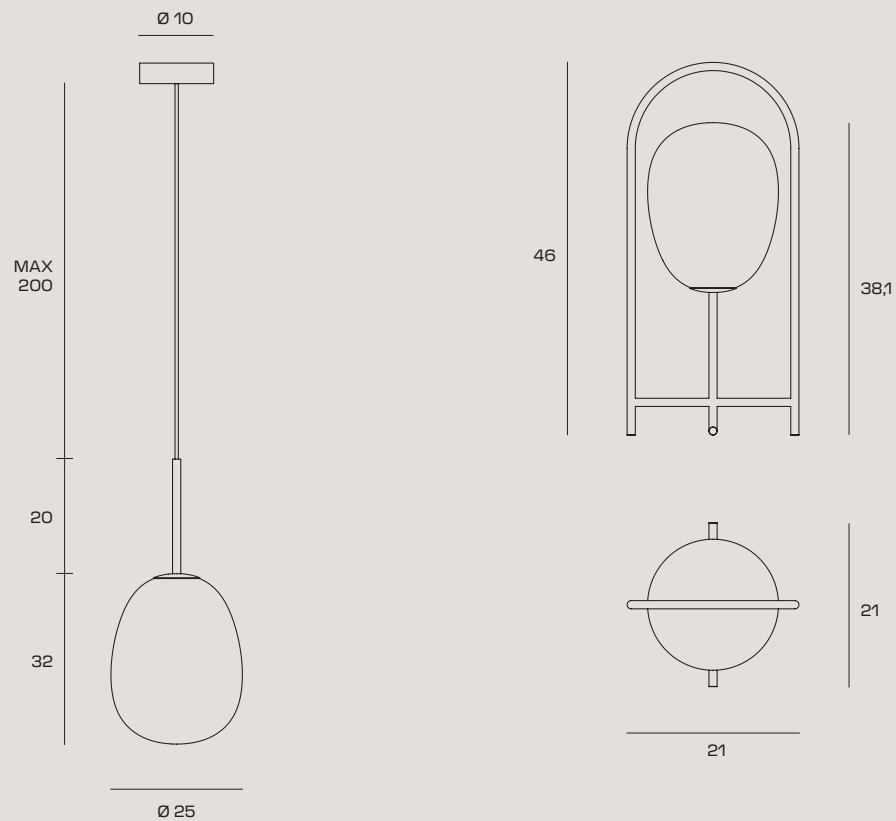

CODE	1744.312.Black	1744.312.Gold
COLOR	● Black	● Gold

### LIGHT SOURCE

Source E27 LED DIMMABLE | Power 1 x max 20w  
Max bulb size: Ø50xH90mm





# BOMBO

## BOMBO

Ispirazione orientale ed illuminazione si incontrano. La lanterna giapponese a cui si ispira il diffusore in vetro opalino di Bombo è sorretta da una base nera definita da un'estetica sobria e minimale. Una composizione che, nella sua essenzialità, differenzia Bombo dalle altre lampade rendendola chiaramente identificabile e consentendole un facile collocamento in ogni scenario.

Oriental inspiration meets lighting. The Japanese lantern to which it is inspired, Bombo's opal glass diffuser, is supported by a black base defined by an understated, minimalist aesthetic. A composition that, in its essentiality, differentiates Bombo from any other lamp, making it clearly identifiable and allowing an easy placement in every scenario.

Orientalische Inspiration und Erleuchtung treffen aufeinander. Die japanische Laterne, die als Inspiration für den Opalglasdiffusor von Bombo diente, wird von einem schwarzen Sockel getragen, der sich durch eine nüchterne, minimalistische Ästhetik auszeichnet. Eine Komposition, die Bombo in ihrer Wesentlichkeit von anderen Leuchten unterscheidet, sie eindeutig identifizierbar macht und es ihr ermöglicht, sich problemlos in jede Umgebung einzufügen.

L'inspiration orientale et l'illumination se rencontrent. La lanterne japonaise dont s'inspire le diffuseur Bombo en verre opalin repose sur une base noire à l'esthétique dépouillée. Une composition à l'aspect essentiel, qui distingue Bombo des autres lampes et lui confère toute sa personnalité et lui permet de s'intégrer à tous les types d'environnements.



# BOMBO

SUSPENSION



# BOMBO

SUSPENSION



# BOMBO

TABLE





# BOMBO

WALL LAMP



# BOMBO

CEILING LAMP



# BOMBO

CEILING LAMP



# BOMBO

FLOOR LAMP



# BOMBO

## SUSPENSION

Lampada sospensione  
con particolari verniciati nero.  
Diffusore in vetro soffiato bianco opale.  
Cavo di alimentazione trasparente 200 cm.

Pendant light with black painted details.  
Opal white blown glass diffuser.  
Clear cable 200 cm.

Pendelleuchte mit Kugelglas  
und schwarz lackierten Details.  
Leuchtschirm aus geblasenem  
Glas in Opalweiß.  
Stromkabel transparent, 200 cm.

Suspension  
avec détails peints noir.  
Diffuseur en verre soufflé blanc opaline  
Câble d'alimentation transparent 200 cm.

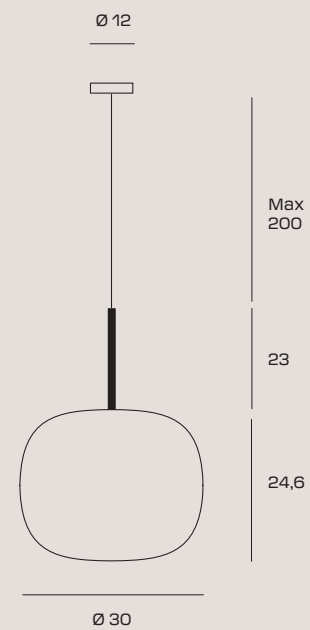

CODE	1744.34
COLOR	● Black

### LIGHT SOURCE

Source E27 LED | Power 1 x max 20w  
Max bulb size: Ø65xH150mm



# BOMBO

## SUSPENSION

Sospensione a 2 luci  
con particolari verniciati nero.  
Diffusore in vetro soffiato bianco opale.  
Dotata di Kit di decentramento  
e cavi di alimentazione  
trasparenti 200 cm.

2-light pendant in opal white  
with black painted details.  
Opal white blown glass diffuser.  
Equipped with decentralisation kit  
and 200 cm. clear cables.

Pendelleuchte mit 2 Kugelgläsern  
aus geblasenem Glas in Opalweiß  
und schwarz lackierten Details.  
Set für dezentrale Montage.  
Stromkabel transparent, 200 cm.

Suspension à 2 points lumineux  
avec détails peints en noir.  
Diffuseur en verre soufflé blanc opaline  
Équipé d'un kit de décentralisation  
et câbles d'alimentation.  
transparent 200 cm.

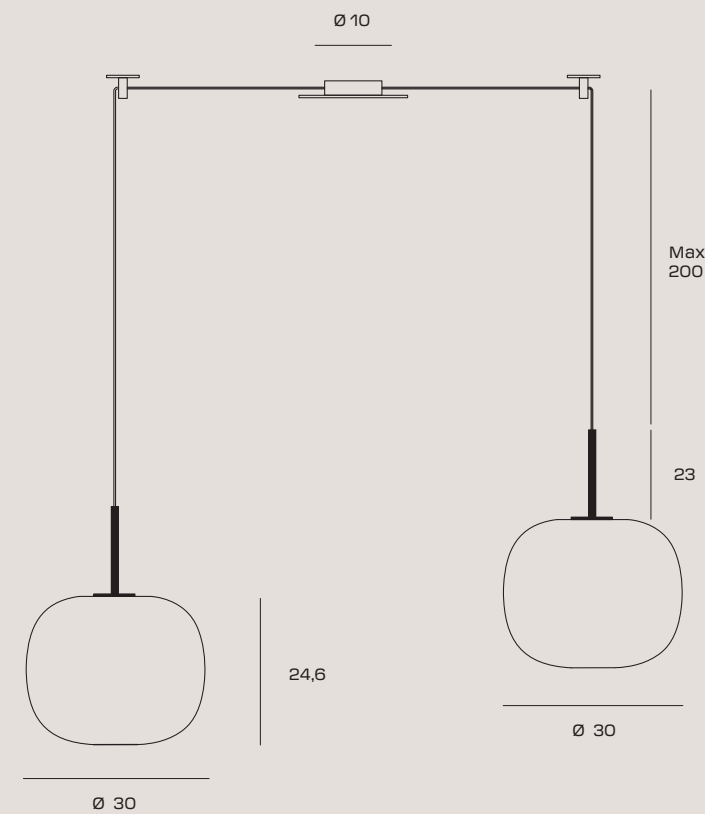

CODE	1744.123.KIT
COLOR	● Black

### LIGHT SOURCE

Source E27 LED | Power 2 x max 20w  
Max bulb size: Ø65xH150mm

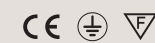

# BOMBO

## TABLE

Lampada da tavolo  
in vetro soffiato bianco  
latte diametro cm 15.  
Montatura verniciata nero.  
Cavo di alimentazione  
trasparente con dimmer.

Table lamp in milky white  
blown glass, measuring  
15 cm in diameter.  
Black painted body.  
Clear cable with  
dimmer switch.

Tischleuchte mit Leuchtschirm  
aus geblasenem Glas in  
Milchweiß, Durchmesser 15 cm.  
Standfuß schwarz lackiert.  
Stromkabel transparent  
mit Dimmer.

Lampe de table  
en verre soufflé blanc  
laiteux diamètre 15 cm.  
Monture peinte en noir.  
Câble d'alimentation  
transparent avec variateur.

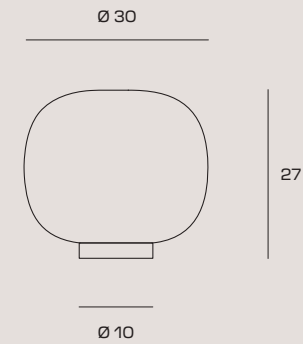
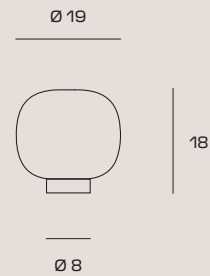

# BOMBO

## TABLE

Lampada da tavolo  
in vetro soffiato bianco  
latte diametro cm 30.  
Montatura verniciata nero.  
Cavo di alimentazione  
trasparente con dimmer.

Table lamp in milky white  
blown glass, measuring  
30 cm in diameter.  
Black painted body.  
Clear cable with  
dimmer switch.

Tischleuchte mit Leuchtschirm  
aus geblasenem Glas in  
Milchweiß, Durchmesser 30 cm.  
Standfuß schwarz lackiert.  
Stromkabel transparent  
mit Dimmer.

Lampe de table  
en verre soufflé blanc  
laiteux diamètre 30 cm.  
Monture peinte en noir.  
Câble d'alimentation  
transparent avec variateur.

CODE 1744.126

COLOR ● Black

### LIGHT SOURCE



Source E27 LED DIMMABLE | Power 1 x max 20w  
Max bulb size: Ø65xH150mm



CODE 1744.127

COLOR ● Black

### LIGHT SOURCE



Source E27 LED DIMMABLE | Power 1 x max 20w  
Max bulb size: Ø65xH150mm



# BOMBO

## WALL LAMP

Lampada da parete  
in metallo verniciato nero.  
Diffusore in vetro  
soffiato bianco opale.

Wall light with  
black painted body.  
Opal white blown  
glass diffuser.

Wandleuchte mit  
Halterung aus schwarzem,  
pulverbeschichtetem Metall.  
Kugelglas aus geblasenem  
Glas in Opalweiß.

Applique  
en métal peint noir  
Diffuseur en verre  
en verre soufflé blanc opaline

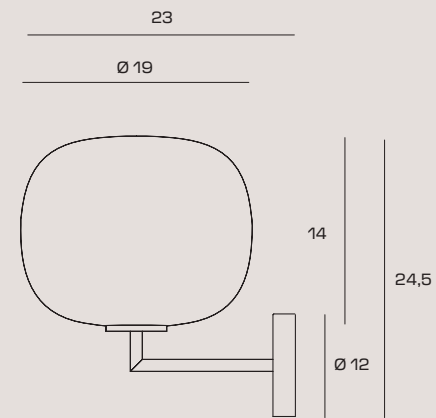

CODE 1744.35

COLOR ● Black

### LIGHT SOURCE

Source E27 LED | Power 1 x max 20w  
Max bulb size: Ø50xH100mm



# BOMBO

## CEILING LAMP

Lampada da soffitto  
in vetro soffiato bianco  
latte diametro cm 19.  
Montatura in metallo  
verniciato nero.

Ceiling light in milky white  
blown glass, measuring  
19 cm in diameter.  
Black painted body.

Deckenleuchte aus  
geblasenem Glas in  
Milchweiß, Durchmesser  
19 cm. Halterung aus  
Metall, schwarz lackiert.

Plafonnier  
en verre soufflé blanc  
laiteux diamètre 19 cm.  
Monture en métal  
peint noir.

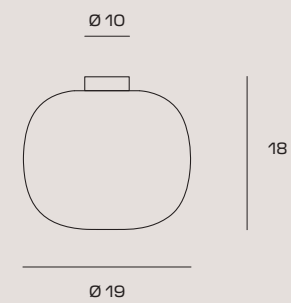

CODE 1744.124

COLOR ● Black

### LIGHT SOURCE

Source E27 LED | Power 1 x max 20w  
Max bulb size: Ø50xH100mm



# BOMBO

## WALL LAMP

Lampada da soffitto  
in vetro soffiato bianco  
latte diametro cm 30.  
Montatura in metallo  
verniciato nero.

Ceiling light in milky  
white blown glass,  
measuring 30 cm  
in diameter.  
Black painted body.

Deckenleuchte aus  
geblasenem Glas  
in Milchweiß,  
Durchmesser 30 cm.  
Halterung aus Metall,  
schwarz lackiert.

Plafonnier  
en verre soufflé blanc  
laiteux diamètre 30 cm.  
Monture en métal  
peint noir.

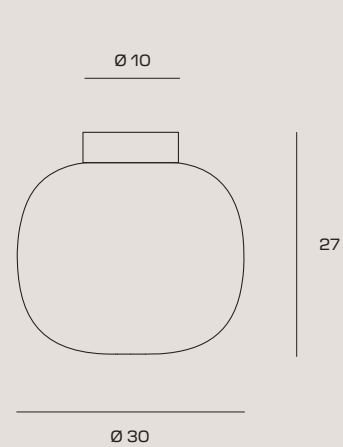

CODE	1744.125
COLOR	● Black

### LIGHT SOURCE

Source E27 LED | Power 1 x max 20w  
Max bulb size: Ø65xH150mm



# BOMBO

## FLOOR LAMP

Lampada da terra in  
metallo verniciato nero.  
Diffusore in vetro  
soffiato bianco opale.  
Cavo di alimentazione trasparente.  
Dotata di dimmer a piede.

Floor lamp with black finish body.  
Opal white blown glass diffuser.  
Clear cable.  
Equipped with foot-operated  
dimmer switch.

Stehleuchte mit Standfuß  
aus schwarzem,  
pulverbeschichtetem Metall.  
Leuchtschirm aus  
geblasenem Glas in Opalweiß.  
Stromkabel transparent.  
Inkl. Dimmer mit Fußschalter.

Lampadaire en  
métal peint noir  
Diffuseur en verre  
en verre soufflé blanc opaline  
Câble d'alimentation transparent.  
Avec variateur à pied.

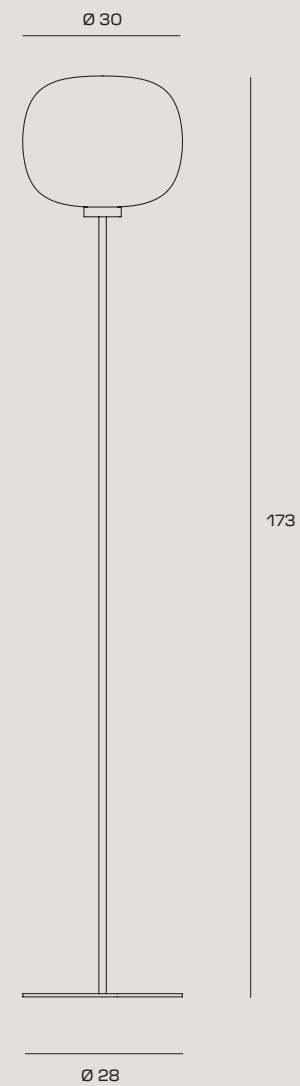

CODE	1744.37
COLOR	● Black

### LIGHT SOURCE

Source E27 LED DIMMABLE | Power 1 x max 30w  
Max bulb size: Ø65xH150mm





# FIFTY

## FIFTY

Atmosfere vintage, tendenze contemporanee. Nata per celebrare il passato, Fifty richiama le linee estetiche in voga negli anni '50 coniugandole ad un design contemporaneo: una commistione di stili e tendenze capace di rievocare con fascino le epoche trascorse, rimanendo saldamente ancorata alla modernità. La struttura sottolinea ulteriormente questo viaggio nel tempo, conferendo ricchezza e preziosità alla lampada.

Vintage atmospheres, contemporary trends. Created to celebrate the past, Fifty recalls the aesthetic lines in vogue in the 1950s combining them with contemporary design: a mixture of styles and trends that calls on bygone eras with fascination, while remaining firmly anchored in modernity. The structure further emphasises this journey through time, making the lamp rich and precious.

Vintage-Atmosphäre, zeitgenössische Trends. Um die Vergangenheit zu feiern, erinnert Fifty an die ästhetischen Linien, die in den 1950er Jahren in Mode waren, und kombiniert sie mit zeitgenössischem Design: eine Mischung aus Stilen und Trends, die mit Charme vergangene Epochen heraufbeschwört und gleichzeitig fest in der Moderne verankert ist. Die Struktur unterstreicht diese Reise durch die Zeit und verleiht der Lampe Reichtum und Kostbarkeit.

Ambiances vintage, tendances contemporaines. Créée en hommage au passé, Fifty reprend l'esthétique des années 50 en la mariant à un design contemporain : un mélange de styles et de tendances qui évoque brillamment des époques révolues, tout en restant fermement ancré dans la modernité. La structure souligne encore davantage ce voyage dans le temps et confère tout son raffinement à la lampe.

# FIFTY

WALL LAMP





# FIFTY

WALL LAMP



# FIFTY

## WALL LAMP

Lampada da parete con struttura in ottone spazzolato o nero o acciaio spazzolato e diffusore in vetro soffiato bianco opale. Punto luce orientabile.

Wall lamp with brushed brass, black or steel body and opal white blown glass diffuser. Adjustable light point.

Wandleuchte mit Halterung aus gebürstetem Messing oder schwarz oder gebürstetem Stahl und Leuchtschirm aus geblasenem Glas in Opalweiß. Orientierbarer Lichtpunkt.

Applique avec structure en laiton brossé ou noir, ou en acier brossé et diffuseur en verre soufflé blanc opaline. Point lumineux orientable.

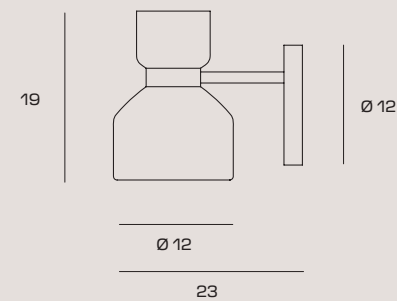

CODE	1744.17	1744.17.Black	1744.17.AC
COLOR	● Brushed Brass	● Black	● Brushed Steel

### LIGHT SOURCE

Source E14 LED | Power 1 x max 20w  
Max bulb size: Ø110xH80mm



# FIFTY

## FLOOR LAMP

Lampada da terra con struttura in ottone spazzolato o nero o acciaio spazzolato e diffusore in vetro soffiato bianco opale. Cavo elettrico rivestito con guaina in PVC colore trasparente con pulsante on/off. Punto luce orientabile.

Floor lamp with brushed brass, black or steel body and opal white blown glass diffuser. Clear cables in PVC with on/off switch. Adjustable light source.

Stehleuchte mit Standfuß aus gebürstetem Messing oder schwarz oder gebürstetem Stahl und Leuchtschirm aus geblasenem Glas in Opalweiß. Stromkabel, transparent, PVC-ummantelt, mit Ein-/Aus-Taste. Orientierbarer Lichtpunkt.

Lampadaire à structure en laiton brossé ou noir, ou en acier brossé et diffuseur en verre soufflé blanc opaline. Câble électrique gainé PVC couleur transparente avec bouton marche/arrêt. Point lumineux orientable.

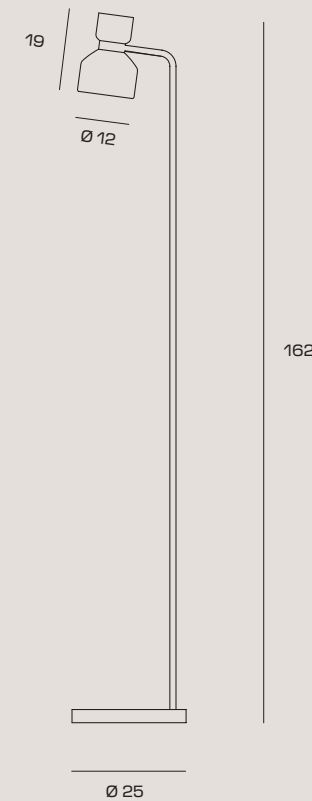

CODE	1744.18	1744.18.Black	1744.18.AC
COLOR	● Brushed Brass	● Black	● Brushed Steel

### LIGHT SOURCE

Source E14 LED DIMMABLE | Power 1 x max 20w  
Max bulb size: Ø110xH80mm





# LUNAR

## LUNAR

Una piramide che sorregge la Luna.  
In Linear una base conica sostiene l'elemento sferico in vetro soffiato, sede del punto luce. Il connubio di due forme elementari, facilmente riconoscibili, fa percepire Linear vicina ed intima, capace di dialogare con qualsiasi contesto e di renderlo caldo e ad accogliente. La finitura in oro spazzolato arricchisce la lampada, la variante nera opaca ne sottolinea la contemporaneità.

A pyramid supporting the Moon.  
In Linear, a conical base supports the spherical blown glass element, which houses the spotlight. The combination of two elementary, easily recognisable shapes makes Linear feel close and intimate, capable of dialoguing with any context and making it warm and cosy. The brushed gold finish enriches the lamp, the matt black variant emphasises its contemporary nature.

Eine Pyramide, die den Mond trägt.  
Bei Linear trägt ein konischer Sockel das kugelförmige mundgeblasene Glaselement, in dem der Lichtpunkt untergebracht ist. Die Kombination zweier elementarer, leicht erkennbarer Formen verleiht Linear ein Gefühl von Nähe und Vertrautheit, das mit jedem beliebigen Produkt in einen Dialog treten kann und es warm und gemütlich machen. Die Ausführung in gebürstetem Gold bereichert die Leuchte, die opak-schwarze Variante unterstreicht ihren modernen Charakter.

Une pyramide soutient la Lune.  
Dans Linear, une base conique supporte l'élément sphérique en verre soufflé, qui renferme le point lumineux. La combinaison de deux formes élémentaires aisément reconnaissables charge Linear d'un sentiment de proximité et d'intimité, et lui permet de dialoguer avec n'importe quel contexte dans une atmosphère chaleureuse et accueillante. La finition en or brossé raffine la lampe, et la variante noire mat souligne son caractère contemporain.

# LUNAR

TABLE



# LUNAR

TABLE





# LUNAR

TABLE

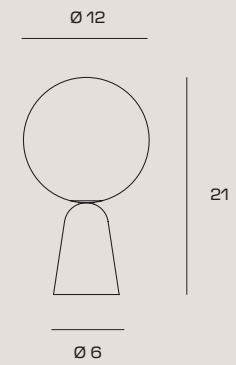

Lampada da tavolo in vetro soffiato bianco latte diametro cm 12. Montatura in ottone spazzolato. Cavo di alimentazione trasparente con dimmer.

Table lamp in milky white blown glass, 12 cm diameter. Brushed brass frame. Transparent power cable with dimmer.

Tischlampe aus mundgeblasenem milchweißem Glas, Durchmesser 12 cm. Fassung aus gebürstetem Messing. Transparentes Stromkabel mit Dimmer.

Lampe à poser en verre soufflé blanc lait, diamètre 12 cm. Structure en laiton brossé. Câble d'alimentation transparent avec variateur.

CODE 1744.150

COLOR ● Brushed Brass

#### LIGHT SOURCE

Source G9 LED DIMMABLE | Power 1 x max 10w  
Max bulb size: Ø20xH80mm



# LUNAR

## TABLE

Lampada da tavolo in vetro soffiato bianco latte diametro cm 20. Montatura in ottone spazzolato. Cavo di alimentazione trasparente con dimmer.

Table lamp in milky white blown glass, 20 cm diameter. Brushed brass frame. Transparent power cable with dimmer.

Tischlampe aus mundgeblasenem milchweißem Glas, Durchmesser 20 cm. Fassung aus gebürstetem Messing. Transparentes Stromkabel mit Dimmer.

Lampe à poser en verre soufflé blanc lait, diamètre 20 cm. Structure en laiton brossé. Câble d'alimentation transparent avec variateur.

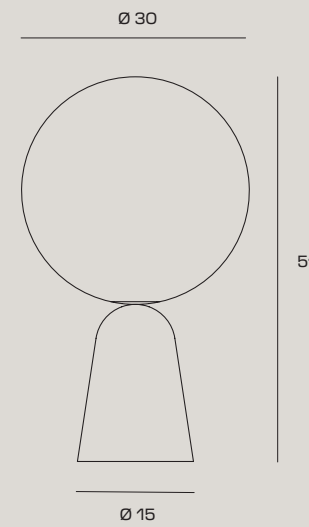
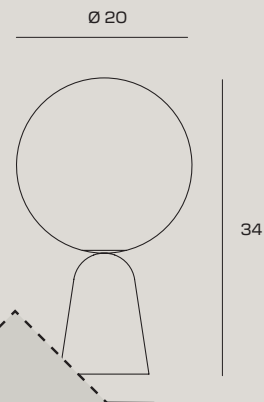

NOT AVAILABLE

CODE	1744.151
COLOR	● Brushed Brass

### LIGHT SOURCE

Source E14 LED DIMMABLE | Power 1 x max 20w  
Max bulb size: Ø50xH140mm



# LUNAR

## TABLE

Lampada da tavolo in vetro soffiato bianco latte diametro cm 30. Montatura in ottone spazzolato o nero opaco. Cavo di alimentazione trasparente con dimmer.

Table lamp with milk-white blown glass. Diameter: 30 cm. Brushed brass or matt black mount. Transparent power supply cable with dimmer.

Tischleuchte aus mundgeblasenem milchweißem Glas, Durchmesser 30 cm. Fassung aus gebürstetem Messing oder mattschwarz. Transparentes Stromkabel mit Dimmer.

Lampe à poser en verre soufflé blanc lait, diamètre 30 cm. Structure en laiton brossé ou noir mat. Câble d'alimentation transparent avec variateur.

CODE	1744.152	1744.296
COLOR	● Brushed Gold	● Black

### LIGHT SOURCE

Source E27 LED DIMMABLE | Power 1 x max 20w  
Max bulb size: Ø65xH240mm





# NEO RETRO

## NEORETRO

La raffinatezza del passato per un innovativo presente. Neoretro coniuga un'estetica dal sapore vintage con elementi moderni, creando un vincente connubio in cui il classico diffusore in vetro opalino bianco è sorretto da una struttura in metallo nero con snodi in ottone. Questo elegante particolare, che dona un appeal ricercato e prezioso a Neoretro, cela una grande funzionalità: la possibilità di orientare il punto luce posizionandolo esattamente dove serve.

The refinement of the past for an innovative present. Neoretro combines a vintage-inspired aesthetic with modern elements, creating a winning combination, in which the classic white opaline glass diffuser is supported by a black metal frame with brass joints. This elegant detail - which gives Neoretro a refined and precious appeal - conceals a great feature: the possibility to steer the spotlight and place it exactly where it is needed.

Die Veredelung der Vergangenheit für eine innovative Gegenwart. Neoretro verbindet die Ästhetik des Vintage-Stils mit modernen Elementen und schafft so eine gelungene Kombination, bei der der klassische Diffusor aus weißem Opalglas von einem schwarzen Metallrahmen mit Messinggelenken getragen wird. Hinter diesem eleganten Detail, das Neoretro einen raffinierten und wertvollen Eindruck verleiht, verbirgt sich eine große Funktionalität: die Möglichkeit, den Lichtpunkt genau dort zu platzieren, wo er gebraucht wird.

Le raffinement du passé pour un présent innovant. Le Neoretro allie esthétique, saveur vintage et éléments modernes, dans une combinaison gagnante où le diffuseur classique en verre opalin blanc est soutenu par une structure en métal noir avec articulations en laiton. Ce détail élégant, qui confère à Neoretro un aspect très raffiné, cache une fonction unique en son genre, la possibilité d'orienter le point lumineux avec précision.



# NEORETRO

SUSPENSION LAMP





# NEORETRO

WALL / CEILING LAMP



# NEORETRO

WALL LAMP







# NEORETRO

## CEILING LAMP

Lampada a sospensione con montatura in metallo verniciato a polvere nero soft touch. Diffusore in vetro soffiato bianco latte di diametro 17,5 cm. Gli snodi in ottone consentono di ruotare il punto luce. Le aste consentono l' utilizzo a sospensione o a plafoniera.

Ceiling lamp with black soft touch powder coated metal frame. Milky white blown glass diffuser measuring 17,5 in diameter. Brass joints can be used to turn the light point.

Deckenlampe mit schwarzem, Soft-Touch-pulverbeschichtetem Metallrahmen und milchig-weißen, aus Glas geblasenen Leuchtschirmen mit einem Durchmesser von 17,5 cm. Die Messingelenke können zusammen mit dem Lichtpunkt gedreht werden und die beweglichen Gestellarme ermöglichen den Einsatz als Pendel- oder Deckenleuchte.

Suspension avec monture en métal peint noir soft touch, Diffuseur en verre soufflé blanc laiteux diamètre 17,5 cm. Les articulations en laiton permettent de faire pivoter le point lumineux. Les baguettes peuvent être utilisées pour suspension ou plafonnier.

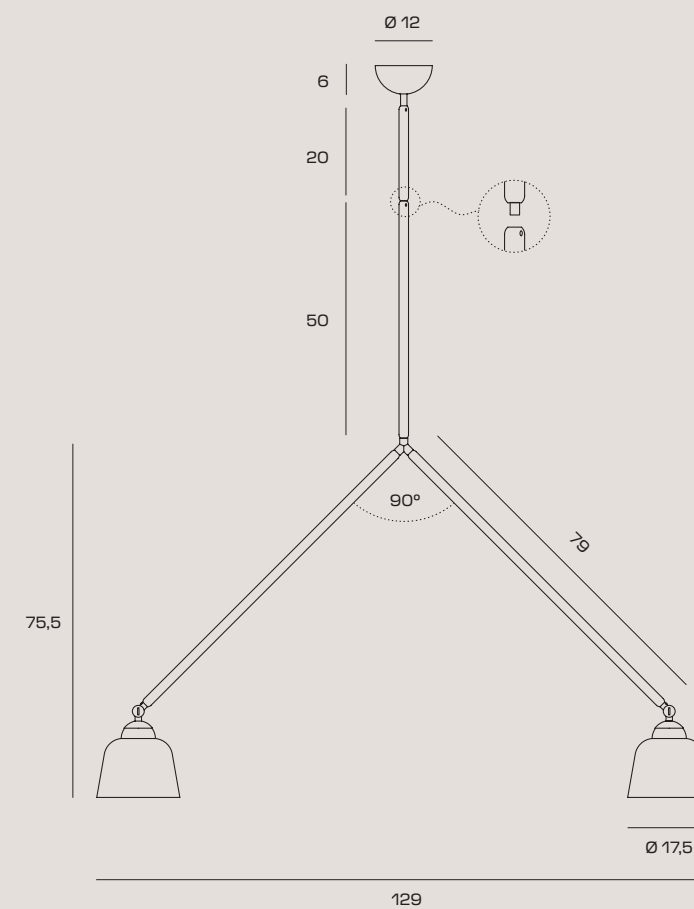

CODE 1744.217

COLOR ● Black

### LIGHT SOURCE

Source E27 LED | Power 2 x max 20w  
Max bulb size: Ø100xH140mm



# NEORETRO

WALL | CEILING LAMP

Lampada da parete o soffitto con montatura in metallo verniciato a polvere nero soft touch. Diffusore in vetro soffiato bianco latte di diametro 17,5 cm. Gli snodi in ottone consentono di alzare o abbassare la lampada secondo le proprie preferenze.

Wall or ceiling lamp with black soft touch powder coated metal frame. Milky white blown glass diffuser measuring 17,5 cm in diameter. Brass joints can be used to raise or lower the lamp according to personal preference.

Wand oder Deckenleuchte mit schwarzem Soft-Touch-pulverbeschichtetem Metallgestell und milchig-weißem, aus Glas geblasenen Leuchtschirm mit einem Durchmesser von 17,5 cm. Die Messinggelenke ermöglichen Ihnen, die Leuchte nach Ihrem Wunsch zu heben oder zu senken.

Applique ou plafonnier avec monture en métal peint noir soft touch. Diffuseur en verre soufflé blanc laiteux 17,5 cm de diamètre. Les articulations en laiton permettent de remonter ou abaisser la lampe selon ses préférences.

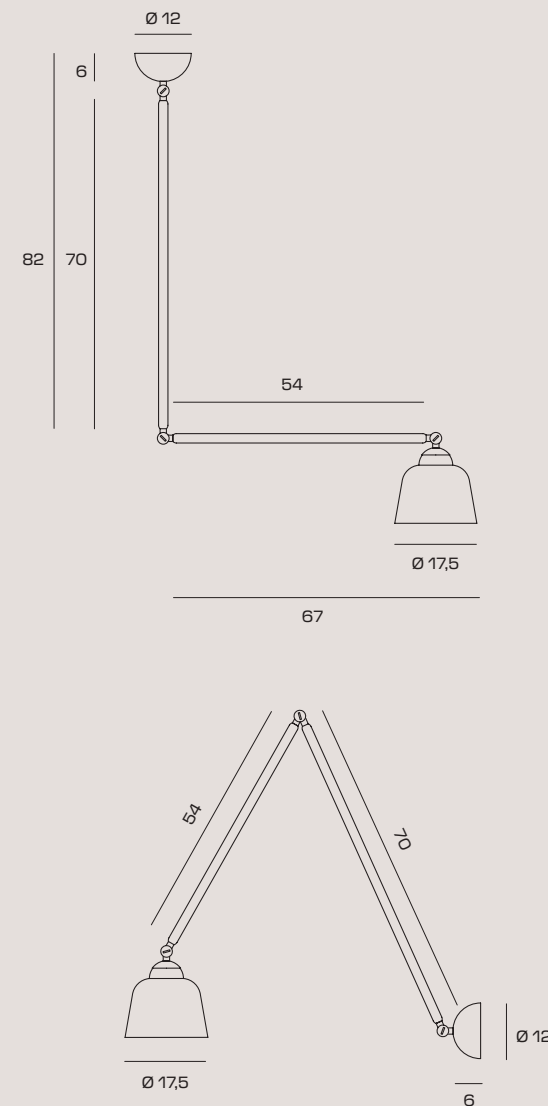

# NEORETRO

CEILING LAMP

Lampada a soffitto con montatura in metallo verniciato a polvere nero soft touch. Diffusore in vetro soffiato bianco latte di diametro 17,5 cm. Gli snodi in ottone consentono di ruotare il punto luce.

Ceiling lamp with black soft touch powder coated metal frame. Milky white blown glass diffuser measuring 17,5 in diameter. Brass joints can be used to turn the light point.

Deckenlampe mit Metallgestell, pulverbeschichtet mit Soft-Touch in Schwarz. Leuchtschirme in Milchweiß aus Glas geblasen, Durchmesser 17,5 cm. Die Messinggelenke ermöglichen Ihnen die das Drehen der Lichtpunkte je nach Wunsch.

Plafonnier avec monture en métal revêtu de peinture poudre noire soft touch. Diffuseur en verre soufflé blanc laiteux 17,5 cm de diamètre. Les articulations en laiton permettent de faire pivoter le point lumineux.

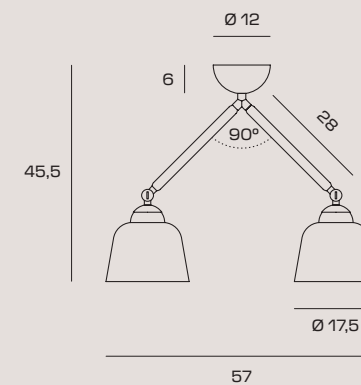

CODE	1744.215
COLOR	● Black

## LIGHT SOURCE

Source E27 LED | Power 1 x max 20w  
Max bulb size: Ø100xH140mm



CODE	1744.216
COLOR	● Black

## LIGHT SOURCE

Source E27 LED | Power 2 x max 20w  
Max bulb size: Ø100xH140mm

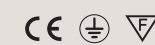

# FRIDA



## FRIDA

Un morbido drappo che avvolge il punto luce, mostrato in tutta la sua essenza grazie alla trasparenza del vetro. Frida è il connubio ideale tra leggerezza ed eleganza, trasmette classe senza ostentazione: i colori del paralume, chiari riferimenti al mondo naturale, si sposano con finiture metalliche che impreziosiscono la lampada senza appesantirla.

A soft drape enveloping the lighting point, shown in all its essence through the transparent glass. Frida is the ideal combination between lightness and elegance, and it conveys unostentatious style. The lampshade colours, clear references to the natural world, are combined with metal finishes that embellish the lamp, without weighing it down.

Ein weicher schleier, der die lichtquelle umhüllt, offenbart in all seiner essenz dank der transparenz des glases. Frida ist die ideale kombination aus leichtigkeit und eleganz, vermittelt klasse ohne prunk: die farben des lampenschirms, eindeutige verweise auf die welt der natur, verschmelzen mit metallischen oberflächen, die die lampe veredeln, ohne sie schwerfällig zu machen.

Un drapé doux qui enveloppe le point lumineux, montré dans toute son essence grâce à la transparence du verre. Frida est l'alliance idéale de la légèreté et de l'élégance, elle transmet la classe sans ostentation : les couleurs de l'abat-jour, des références évidentes au monde naturel, sont associées à des finitions métalliques qui embellissent la lampe sans l'alourdir.

# FRIDA

SUSPENSION





# FRIDA

SUSPENSION



# FRIDA

SUSPENSION



# FRIDA

TABLE







# FRIDA

## SUSPENSION

Lampada a sospensione in vetro borosilicato color verde prato, azzurro cielo o sabbia. Diffusore interno in vetro borosilicato sabbiato. Stelo e rosone in oro spazzolato. Cavo di alimentazione nero 200 cm. Lampadina installabile G9 a LED.

Borosilicate glass suspension lamp available in field green, sky blue or sand. Internal frosted borosilicate glass diffuser. Brushed gold lamp stem and ceiling canopy. Black 200 cm power supply cord. Compatible with G9 LED light bulbs.

Pendelleuchte aus Borosilikatglas in der Farbe Wiesengrün, Himmelblau oder Sand. Innerer Diffusor aus sandgestrahltem Borosilikatglas. Pendelrohr und Baldachin goldfarben, gebürstet. Stromkabel schwarz, 200 cm. Einbaubares Leuchtmittel G9 mit LED.

Suspension en verre borosilicate vert gazon, bleu ciel ou sable. Diffuseur interne en verre borosilicate sablé. Tige et rosace finition en or brossé. Câble d'alimentation noir 200 cm. Possibilité d'installer 1 ampoule LED G9.

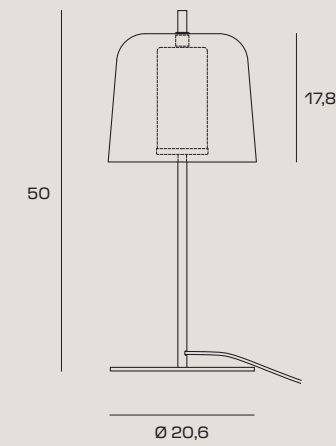
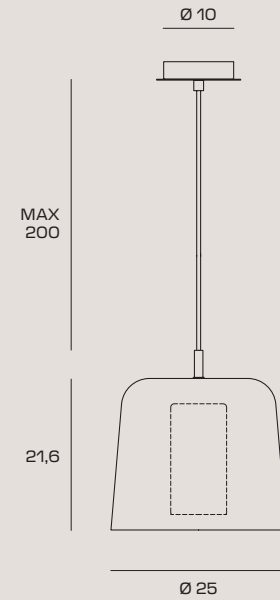

CODE	1744.317.Blusky	1744.317.Lightgreen	1744.317.Sand
GLASS	<span style="color: blue;">●</span> Blu Sky	<span style="color: green;">●</span> Light green	<span style="color: gold;">●</span> Sand
COLOR	<span style="color: gold;">●</span> Brushed Gold	<span style="color: gold;">●</span> Brushed Gold	<span style="color: gold;">●</span> Brushed Gold

### LIGHT SOURCE

 Source G9 LED | Power 1 x max 10w  
Max bulb size: Ø21xH100mm



# FRIDA

## TABLE

Lampada da tavolo in vetro borosilicato color verde prato, azzurro cielo o sabbia. Diffusore interno in vetro borosilicato sabbiato. Stelo in oro spazzolato. Cavo di alimentazione nero 150 cm. Lampadina installabile G9 a LED dimmerabile.

Borosilicate glass table lamp available in field green, sky blue or sand. Internal frosted borosilicate glass diffuser. Brushed gold lamp stem. Black 150 cm power supply cord. Compatible with dimmable G9 LED light bulbs.

Tischleuchte aus Borosilikatglas in der Farbe Wiesengrün, Himmelblau oder Sand. Innerer Diffusor aus sandgestrahltem Borosilikatglas. Pendelrohr und Baldachin goldfarben, gebürstet. Stromkabel schwarz, 150 cm. Einbaubares Leuchtmittel G9 mit LED, dimmbar.

Lampe de table en verre borosilicate vert gazon, bleu ciel ou sable. Diffuseur interne en verre borosilicate sablé. Tige finition en or brossé. Câble d'alimentation noir 150 cm. Possibilité d'installer 1 ampoule LED G9 dimmable.



CODE	1744.313.Blusky	1744.313.Lightgreen	1744.313.Sand
COLOR	<span style="color: blue;">●</span> Blu Sky	<span style="color: green;">●</span> Light green	<span style="color: gold;">●</span> Sand
	<span style="color: gold;">●</span> Brushed Gold	<span style="color: gold;">●</span> Brushed Gold	<span style="color: gold;">●</span> Brushed Gold

### LIGHT SOURCE

 Source G9 LED DIMMABLE | Power | 1 x max 10w  
Max bulb size: Ø21xH100mm





# ALADINO

## WINNER



## ALADINO

Un punto luce che danza nell'aria, con grazia e leggerezza. La quasi totale assenza di struttura rende Aladino estremamente libera e votata all'elevazione. Due semplici cavi la sostengono, l'unica vera protagonista è la luce diffusa da una sfera in vetro satinato incastonata in un bowl in vetro borosilicato trasparente. Nelle sue molteplici composizioni, tutte con finiture in ottone spazzolato, Aladino riempie l'ambiente di bagliori luminosi. Aladino ha ottenuto l'ambito premio Good Design Award.

A spotlight dancing in the air, with grace and lightness. The almost total absence of structure makes Aladdin extremely free and dedicated to elevation. Two simple cables support it, and the only real protagonist is the light diffused by a frosted glass sphere set in a transparent borosilicate glass bowl. In its many compositions, all with brushed brass finish, Aladino fills the room with luminous glow. Aladdin won the coveted Good Design Award.

Ein Lichtpunkt, der in der Luft tanzt, mit Anmut und Leichtigkeit. Das fast völlige Fehlen von Struktur macht Aladino extrem frei und der Höhe verpflichtet. Der einzige wirkliche Protagonist ist das Licht, das von einer matten Glaskugel in einer transparenten Borosilikatglaschale gestreut wird. In ihren vielfältigen Kompositionen, die alle in gebürstetem Messing ausgeführt sind, erfüllt Aladino den Raum mit leuchtendem Glanz. Aladino hat den begehrten Good Design Award gewonnen.

Un point lumineux dansant, gracieux et léger, dans l'air ambiant. Sa quasi-absence de structure rend Aladin parfaitement libre et orienté vers l'élévation. Deux simples câbles le soutiennent, la seule présence réelle étant la lumière diffusée par une sphère en verre dépoli placée dans une sphère en verre borosilicate transparent. Dans ses nombreuses compositions, toutes avec finition en laiton brossé, Aladino diffuse dans la pièce un éclat lumineux. Aladdin a remporté le célèbre prix Good Design Award.

# ALADINO

SUSPENSION





# ALADINO

SUSPENSION



# ALADINO

SUSPENSION



# ALADINO

SUSPENSION





# ALADINO

SUSPENSION

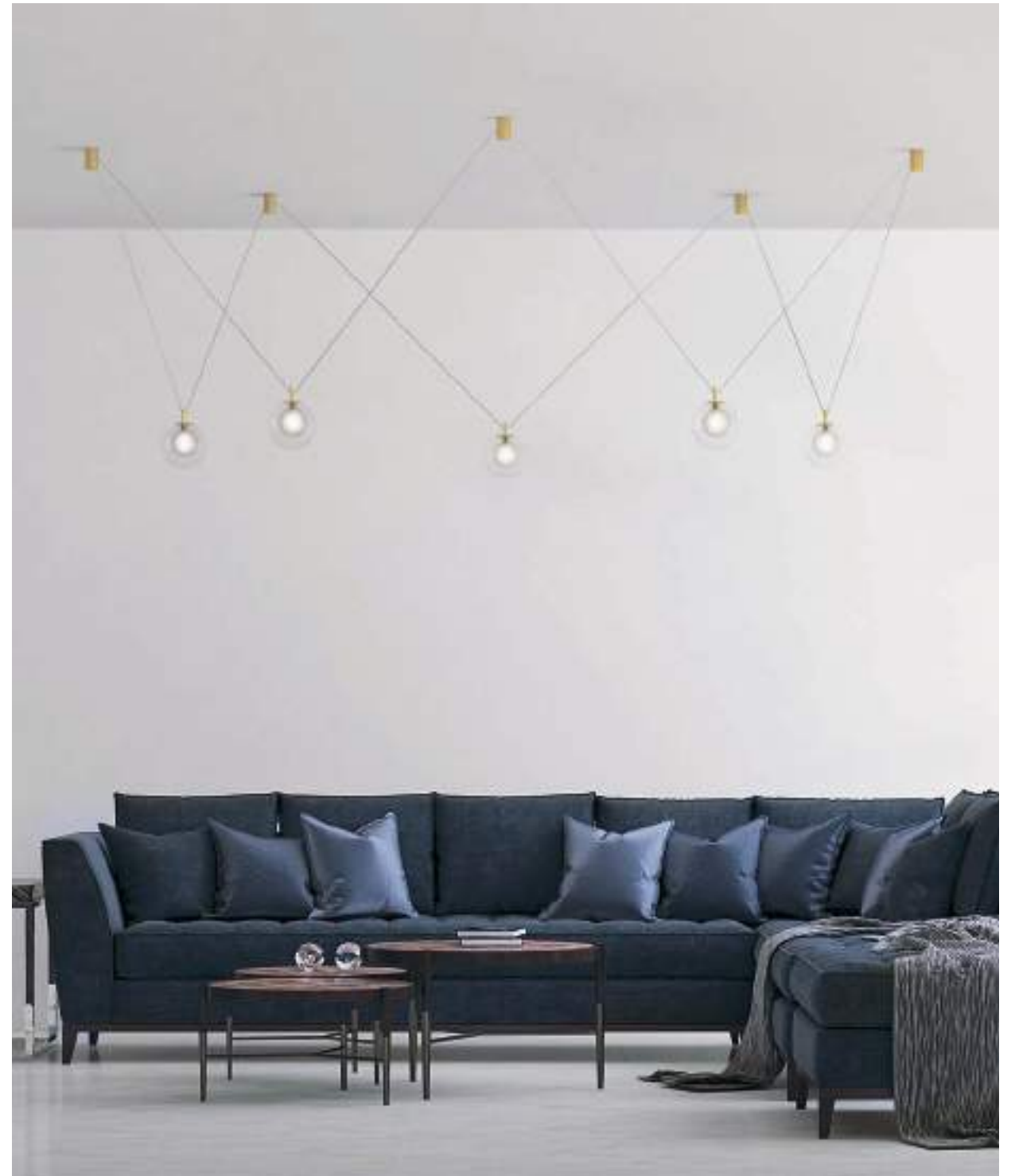







# ALADINO

SUSPENSION





# ALADINO

## SUSPENSION

Lampada a sospensione  
in vetro borosilicato trasparente  
esterno e satinato interno,  
diametro 15 cm,  
altezza cavo cm 200.  
Rosone e parti metalliche  
in oro spazzolato.

Suspension lamp with transparent  
borosilicate glass on the outside  
and satin-finished glass on the inside,  
15 cm diameter,  
200 cm long cable.  
Ceiling canopy and metal  
parts in brushed gold.

Pendelleuchte aus Borosilikatglas,  
Außenfarbe transparent  
und Innenfarbe satiniert,  
Durchmesser 15 cm.  
Kabellänge 200 cm.  
Fassung und Metallteile  
in gebürstetem Gold.

Suspension en verre borosilicate,  
transparent à l'extérieur  
et satiné à l'intérieur,  
diamètre 15 cm,  
longueur du câble 200 cm.  
Rosace et parties  
métalliques en or brossé.

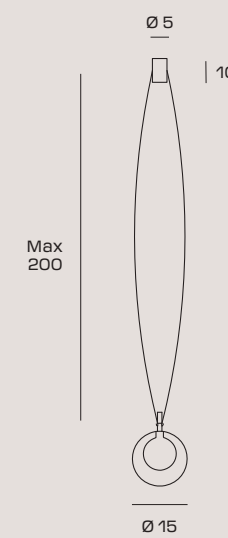
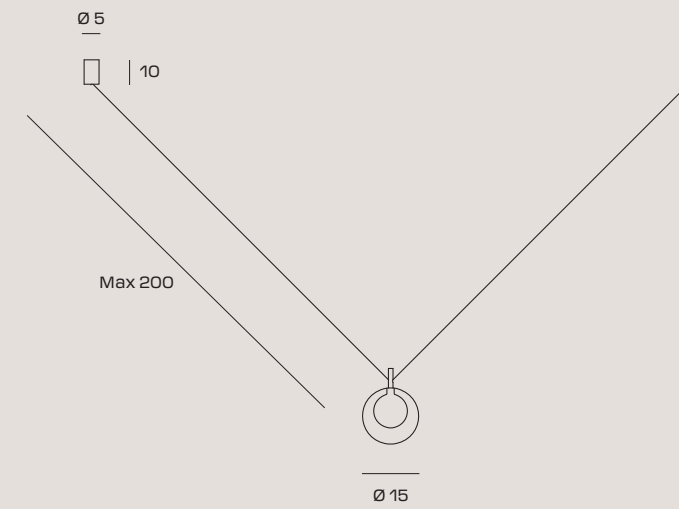

WINNER



CODE	1744.139
GLASS	○ Transparent
COLOR	● Brushed Gold

### LIGHT SOURCE

Source G9 LED | Power 1 x max 10w  
Max bulb size: Ø20xH80mm



# ALADINO

## SUSPENSION

Sospensione a 3 luci in vetro borosilicato trasparente esterno e satinato interno, diametro 15 cm, lunghezza cavo cm 200. Il sistema, composto da parti metalliche in oro spazzolato, ha la possibilità di prendere l'alimentazione in qualsiasi rosone e, attraverso le connessioni, portare illuminazione in ogni punto luce.

3-light pendant in borosilicate glass, clear on the outside with frosted finish on the inside, diameter 15 cm, cable length 200 cm. The system, composed of metallic parts in a brushed gold finish, is designed to allow the power supply to be connected to any ceiling canopy and, through the connections, brings light to every lighting point.

Pendelleuchte mit 3 Kugelgläsern aus Borosilikatglas, außen transparent, innen satiniert, Durchmesser 15 cm, Kabellänge 200 cm. Das Pendelleuchtensystem aus gebürsteten Goldmetallteilen hat die Möglichkeit, die Stromversorgung von beiden Baldachinen aus aufzunehmen.

Suspension à 3 lumières en verre borosilicate, transparent à l'extérieur et satiné à l'intérieur, diamètre 15 cm, longueur du câble 200 cm. Le système, composé de pièces métalliques en or brossé, a la possibilité de prendre le courant de n'importe quelle rosace de plafond et, par le biais de connexions, d'apporter de l'éclairage à n'importe quel point lumineux.

## WINNER



CODE	1744.141
GLASS	<input type="radio"/> Transparent
COLOR	<input checked="" type="radio"/> Brushed Gold

## LIGHT SOURCE

Source G9 LED | Power 3 x max 10w  
Max bulb size: Ø20xH80mm



## ESEMPI DI POSSIBILI CONFIGURAZIONI EXAMPLES OF POSSIBLE CONFIGURATIONS GESTALTUNGSMÖGLICHKEITEN EXEMPLES DE CONFIGURATIONS POSSIBLES

A

CONFIGURAZIONE 3 LUCI IN LINEA  
3 LIGHTS IN LINEAR CONFIGURATION  
GESTALTUNG 3 LINEARE KUGELGLÄSER  
CONFIGURATION 3 LUMIÈRES ALIGNÉES

...E molto altro  
...And many more  
...Und viele weitere möglichkeiten  
...et bien plus encore

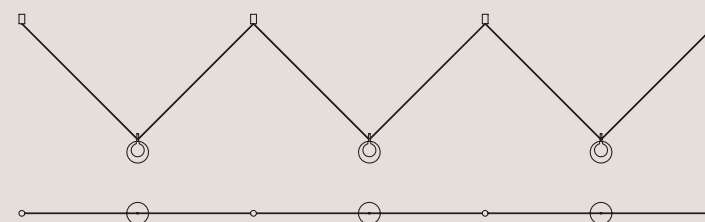

B

CONFIGURAZIONE 3 LUCI IN TONDO  
3 LIGHTS IN CIRCULAR CONFIGURATION  
GESTALTUNG 3 KUGELGLÄSER IM KREIS  
CONFIGURATION À 3 LUMIÈRES EN ARRONDI

...E molto altro  
...And many more  
...Und viele weitere möglichkeiten  
...et bien plus encore

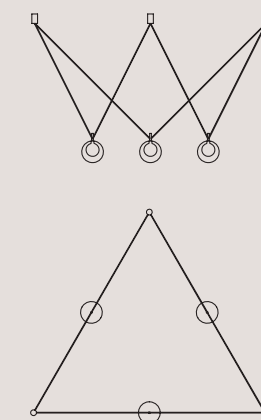

# ALADINO

## SUSPENSION

Sospensione a 5 luci in vetro borosilicato trasparente esterno e satinato interno, diametro 15 cm, lunghezza cavo cm 200. Il sistema, composto da parti metalliche in oro spazzolato, ha la possibilità di prendere l'alimentazione in qualsiasi rosone e, attraverso le connessioni, portare illuminazione in ogni punto luce.

5-light pendant in borosilicate glass, clear on the outside with frosted finish on the inside, diameter 15 cm, cable length 200 cm. The system, composed of metallic parts in a brushed gold finish, is designed to allow the power supply to be connected to any ceiling canopy and, through the connections, brings light to every lighting point.

Pendelleuchte mit 5 Kugelgläsern aus Borosilikatglas, außen transparent, innen satiniert, Durchmesser 15 cm, Kabellänge 200 cm. Das Pendelleuchtsystem aus gebürsteten Goldmetallteilen hat die Möglichkeit, die Stromversorgung von beiden Baldachinen aus aufzunehmen und über die Anschlüsse in jede Lichtposition zu leiten.

Suspension à 5 lumières en verre borosilicate, transparent à l'extérieur et satiné à l'intérieur, diamètre 15 cm, longueur du câble 200 cm. Le système, composé de pièces métalliques en or brossé, a la possibilité de prendre le courant dans n'importe quelle rosace de plafond et, par le biais de connexions, d'apporter de l'éclairage à chaque point lumineux.

### WINNER



CODE	1744.144
GLASS	<input type="radio"/> Transparent
COLOR	<input checked="" type="radio"/> Brushed Gold

### LIGHT SOURCE

Source G9 LED | Power 5 x max 10w  
Max bulb size: Ø20xH80mm



## ESEMPI DI POSSIBILI CONFIGURAZIONI EXAMPLES OF POSSIBLE CONFIGURATIONS GESTALTUNGSMÖGLICHKEITEN EXEMPLES DE CONFIGURATIONS POSSIBLES

A

CONFIGURAZIONE 5 LUCI IN LINEA  
5 LIGHTS IN LINEAR CONFIGURATION  
GESTALTUNG 5 LINEARE KUGELGLÄSER  
CONFIGURATION 5 LUMIÈRES ALIGNÉES

...E molto altro  
...And many more  
...Und viele weitere möglichkeiten  
...et bien plus encore

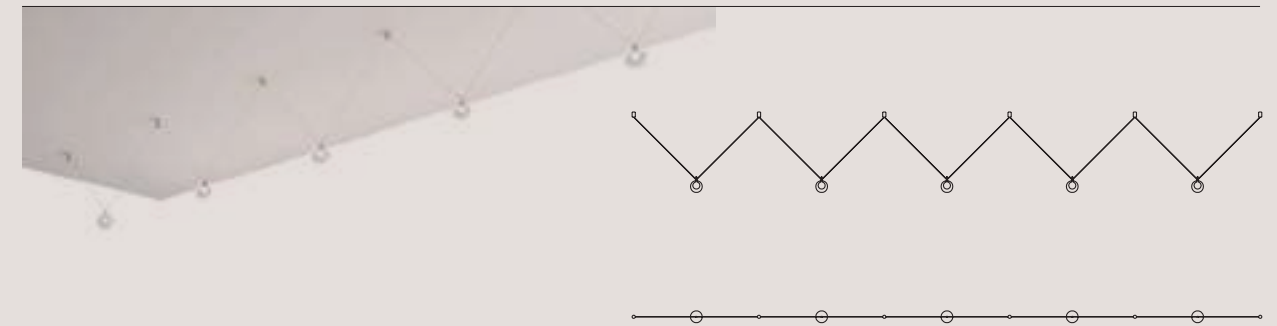

B

CONFIGURAZIONE 5 LUCI INCROCIATE  
5 LIGHTS IN CROSSED CONFIGURATION  
GESTALTUNG 5 LINEARE KUGELGLÄSER  
CONFIGURATION 5 LUMIÈRES CROISÉES

...E molto altro  
...And many more  
...Und viele weitere möglichkeiten  
...et bien plus encore

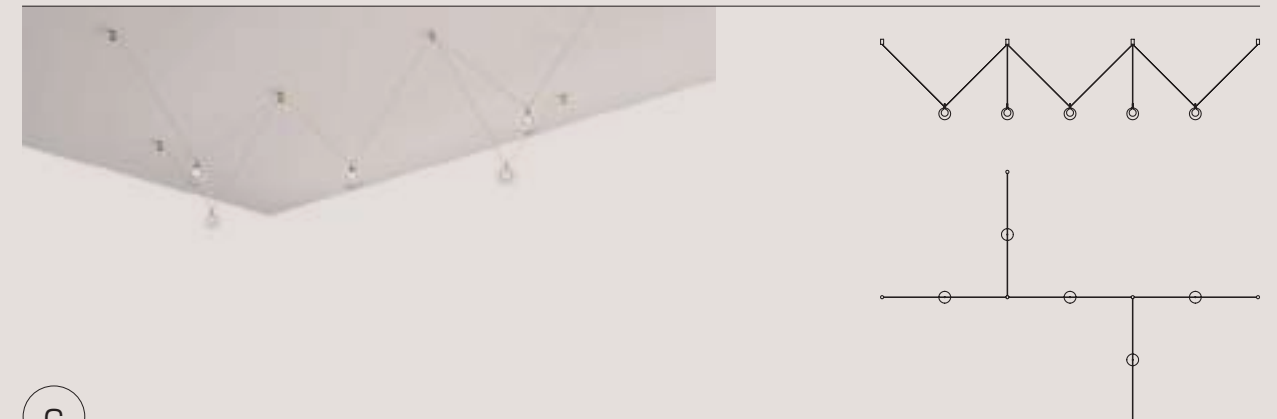

C

CONFIGURAZIONE 5 LUCI IN TONDO  
5 LIGHTS IN CIRCULAR CONFIGURATION  
GESTALTUNG 5 LINEARE KUGELGLÄSER  
CONFIGURATION À 5 LUMIÈRES EN ARRONDI

...E molto altro  
...And many more  
...Und viele weitere möglichkeiten  
...et bien plus encore

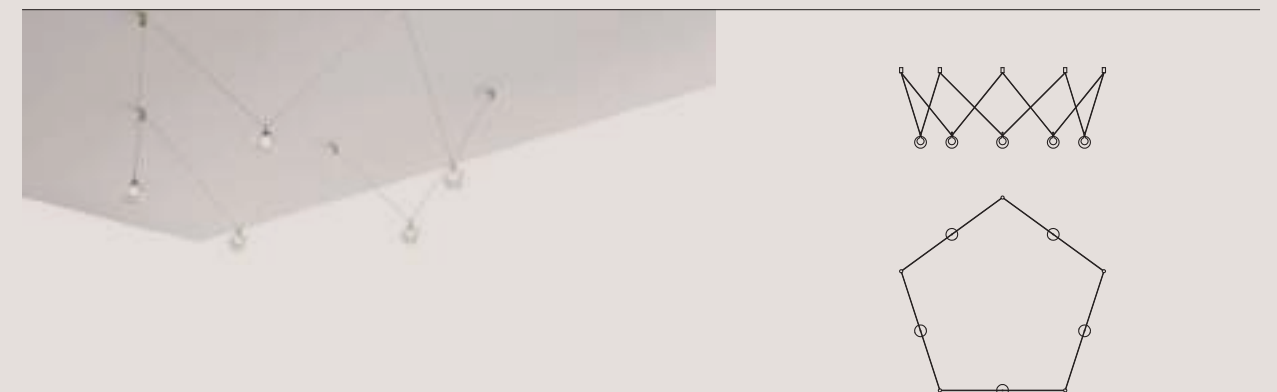

# ALADINO

## SUSPENSION

Sospensione a 10 luci in vetro borosilicato trasparente esterno e satinato interno, diametro 15 cm, lunghezza cavo cm 200. Il sistema, composto da parti metalliche in oro spazzolato, ha la possibilità di prendere l'alimentazione in qualsiasi rosone e, attraverso le connessioni, portare illuminazione in ogni punto luce.

10-light pendant in borosilicate glass, clear on the outside with frosted finish on the inside, diameter 15 cm, cable length 200 cm. The system, composed of metallic parts in a brushed gold finish, is designed to allow the power supply to be connected to any ceiling canopy and, through the connections, brings light to every lighting point.

Pendelleuchte mit 10 Kugelgläsern aus Borosilikatglas, außen transparent, innen satiniert, Durchmesser 15 cm, Kabellänge 200 cm. Das Pendelleuchtensystem aus gebürsteten Goldmetallteilen hat die Möglichkeit, die Stromversorgung von beiden Baldachinen aus aufzunehmen und über die Anschlüsse in jede Lichtposition zu leiten.

Suspension à 10 lampes en verre borosilicate, extérieur transparent et satiné à l'intérieur, diamètre 15 cm, longueur du câble 200 cm. Le système, composé de pièces métalliques en or brossé, a la possibilité de prendre le courant de n'importe quelle rosace de plafond et, par le biais de connexions, d'apporter de l'éclairage à n'importe quel point lumineux.

## WINNER



CODE	1744.149
GLASS	<input type="radio"/> Transparent
COLOR	<input checked="" type="radio"/> Brushed Gold

## LIGHT SOURCE

Source G9 LED | Power 10 x max 10w  
Max bulb size: Ø20xH80mm



## ESEMPI DI POSSIBILI CONFIGURAZIONI EXAMPLES OF POSSIBLE CONFIGURATIONS GESTALTUNGSMÖGLICHKEITEN EXEMPLES DE CONFIGURATIONS POSSIBLES

A

CONFIGURAZIONE 10 LUCI IN LINEA  
10 LIGHTS IN LINEAR CONFIGURATION  
GESTALTUNG 10 LINEARE KUGELGLÄSER  
CONFIGURATION 10 LUMIÈRES ALIGNÉES

...E molto altro  
...And many more  
...Und viele weitere möglichkeiten  
...et bien plus encore

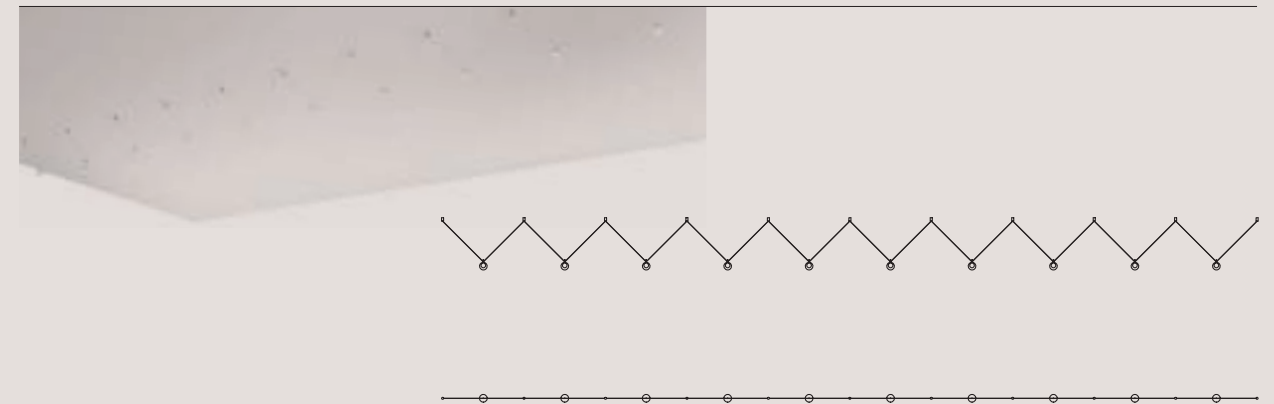

B

CONFIGURAZIONE 10 LUCI A CROCE  
10 LIGHTS IN CROSSED CONFIGURATION  
GESTALTUNG 10 KUGELGLÄSER KREUZFÖRMIG  
CONFIGURATION À 10 LUMIÈRES CROISÉES

...E molto altro  
...And many more  
...Und viele weitere möglichkeiten  
...et bien plus encore

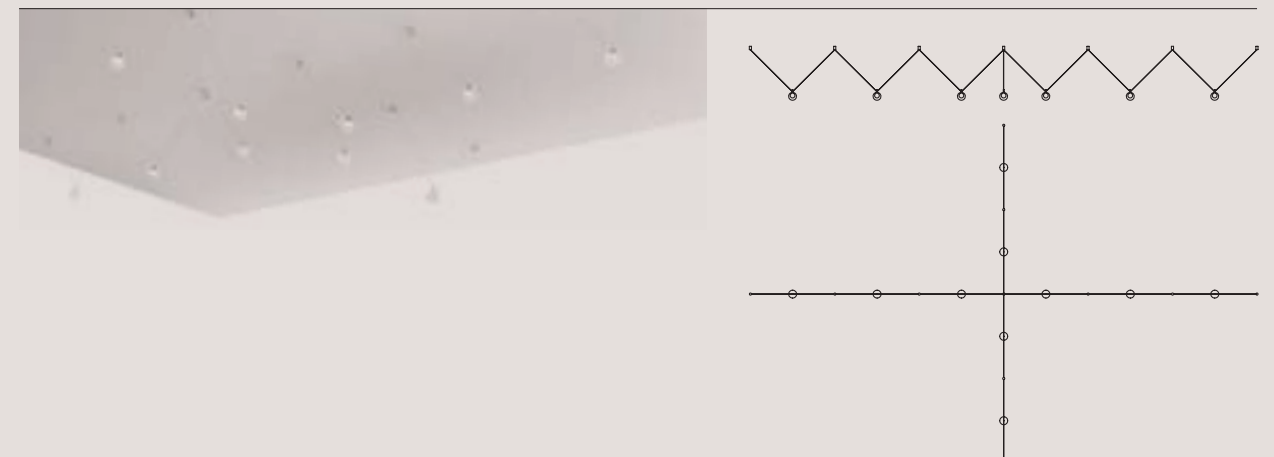

C

CONFIGURAZIONE 10 LUCI IN RETTANGOLO  
10 LIGHTS IN RECTANGULAR CONFIGURATION  
GESTALTUNG 10 KUGELGLÄSER IM RECHTECK  
CONFIGURATION À 10 LUMIÈRES EN RECTANGLE

...E molto altro  
...And many more  
...Und viele weitere möglichkeiten  
...et bien plus encore

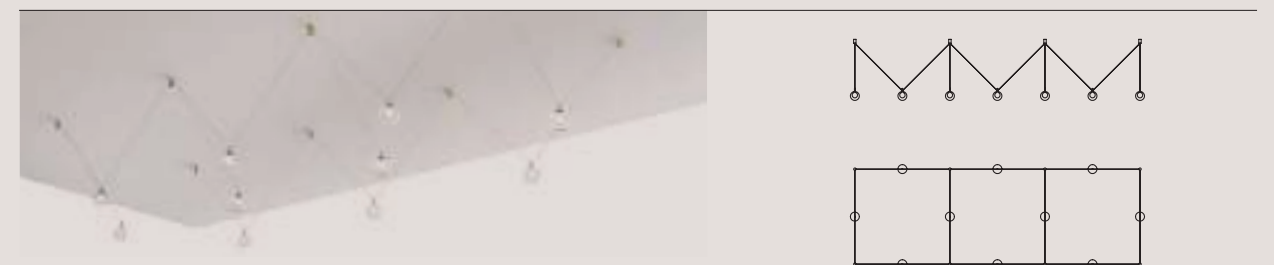

# ALADINO

## SUSPENSION

Sospensione a 12 luci in vetro borosilicato trasparente esterno e satinato interno, diametro 15 cm, lunghezza cavo cm 200. Il sistema, composto da parti metalliche in oro spazzolato, ha la possibilità di prendere l'alimentazione in qualsiasi rosone e, attraverso le connessioni, portare illuminazione in ogni punto luce.

12-light pendant in borosilicate glass, clear on the outside with frosted finish on the inside, diameter 15 cm, cable length 200 cm. The system, composed of metallic parts in a brushed gold finish, is designed to allow the power supply to be connected to any ceiling canopy and, through the connections, brings light to every lighting point.

Pendelleuchte mit 12 Kugelgläsern aus Borosilikatglas, außen transparent, innen satiniert, Durchmesser 15 cm, Kabellänge 200 cm. Das Pendelleuchtensystem aus gebürsteten Goldmetallteilen hat die Möglichkeit, die Stromversorgung von beiden Baldachinen aus aufzunehmen und über die Anschlüsse in jede Lichtposition zu leiten.

Suspension à 12 lumières en verre borosilicate transparent à l'extérieur et satiné à l'intérieur, diamètre 15 cm, longueur du câble 200 cm. Le système, composé de pièces métalliques en or brossé, a la possibilité de prendre le courant de n'importe quelle rosace de plafond et, par le biais de connexions, d'apporter de l'éclairage à n'importe quel point lumineux.

## WINNER



CODE	1744.172
GLASS	<input type="radio"/> Transparent
COLOR	<input checked="" type="radio"/> Brushed Gold

## LIGHT SOURCE

 Source G9 LED | Power 12 x max 10w  
Max bulb size: Ø20xH80mm



## ESEMPI DI POSSIBILI CONFIGURAZIONI EXAMPLES OF POSSIBLE CONFIGURATIONS GESTALTUNGSMÖGLICHKEITEN EXEMPLES DE CONFIGURATIONS POSSIBLES

A

CONFIGURAZIONE 12 LUCI IN RETTANGOLO  
12 LIGHTS IN RECTANGULAR CONFIGURATION  
GESTALTUNG 12 KUGELGLÄSER IM RECHTECK  
CONFIGURATION À 12 LUMIÈRES EN RECTANGLE

...E molto altro  
...And many more  
...Und viele weitere möglichkeiten  
...et bien plus encore

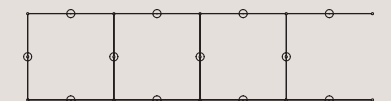

B

CONFIGURAZIONE 12 LUCI IN TONDO  
12 LIGHTS IN CIRCULAR CONFIGURATION  
GESTALTUNG 12 KUGELGLÄSER IM KREIS  
CONFIGURATION À 12 LUMIÈRES EN ARRONDI

...E molto altro  
...And many more  
...Und viele weitere möglichkeiten  
...et bien plus encore

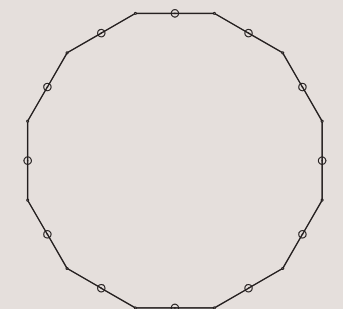



# X-RAY

*Brera Edition*

## X-RAY

La rivelazione.  
Una vera manifestazione della luce.  
L'intimità di X-Ray nella nuova versione Brera Edition è celata dalle finiture rame, bronzo ed oro e si svela soltanto all'accensione. Superfici nette in vetro, addolcite da delicate curvature che donano movimento ed eleganza, custodiscono il punto luce. Ogni versione ha un'identità forte e definita, che si raccorda armoniosamente alle altre. Brera Edition trova la sua naturale collocazione in contesti d'élite.

The revelation, a true epiphany of light.  
X-Ray's intimacy, in the new Brera Edition, is hidden by copper, bronze and gold finishes, and unveiled only once it is turned on. Stark glass surfaces, embellished by gentle curves that add movement and elegance, guarding the spot light. Every version has its own strong identity, harmoniously connected to the others. Brera Edition finds its natural placement in elite contexts.

Die Offenbarung.  
eine regelrechte manifestation des lichts.  
Die intimität von X-Ray in der neuen Brera Edition wird von der ausführung in kupfer, bronze und gold verhüllt und offenbart sich erst beim einschalten.  
Klare oberflächen aus glas, abgemildert von sanften kurven, die für bewegung und eleganz sorgen, bergen die lichtquelle. Jede version besitzt eine starke und definierte identität, die sich harmonisch mit den anderen verbindet. Brera Edition findet ihren natürlichen platz in elitären kontexten.

La révélation.  
Une véritable manifestation de la lumière.  
L'intimité de X-Ray de la nouvelle version Brera Edition est dissimulée par les finitions cuivre, bronze et or et n'est révélée qu'à l'allumage. Les surfaces en verre clair, adoucies par des courbes délicates qui donnent du mouvement et de l'élégance, protègent le point lumineux. Chaque version a une identité forte et définie, qui se connecte harmonieusement aux autres. Brera Edition trouve sa place naturelle dans des contextes d'élite.

# X-RAY

SUSPENSION



# X-RAY

SUSPENSION

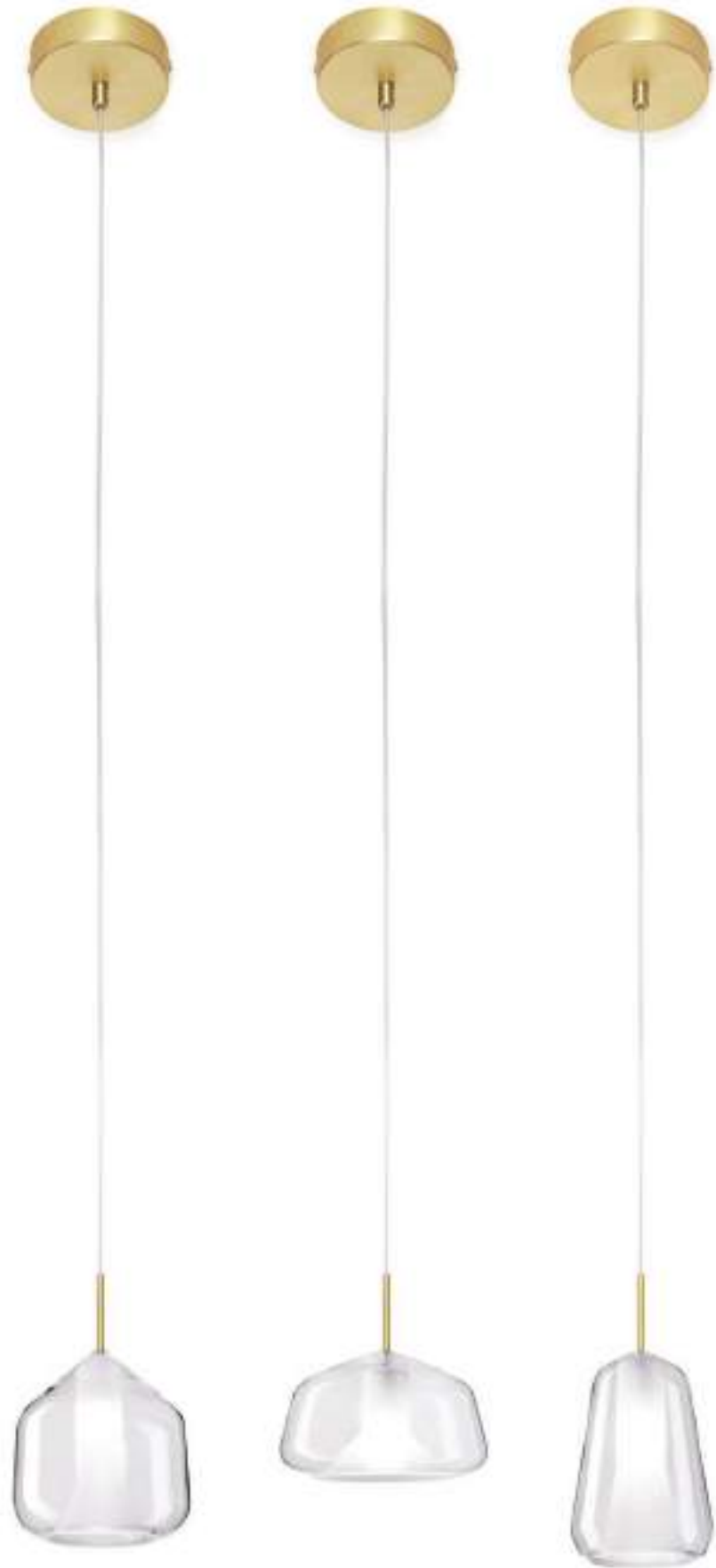



# X-RAY

SUSPENSION







# X-RAY

SUSPENSION



# X-RAY

SUSPENSION







# X-RAY

SUSPENSION



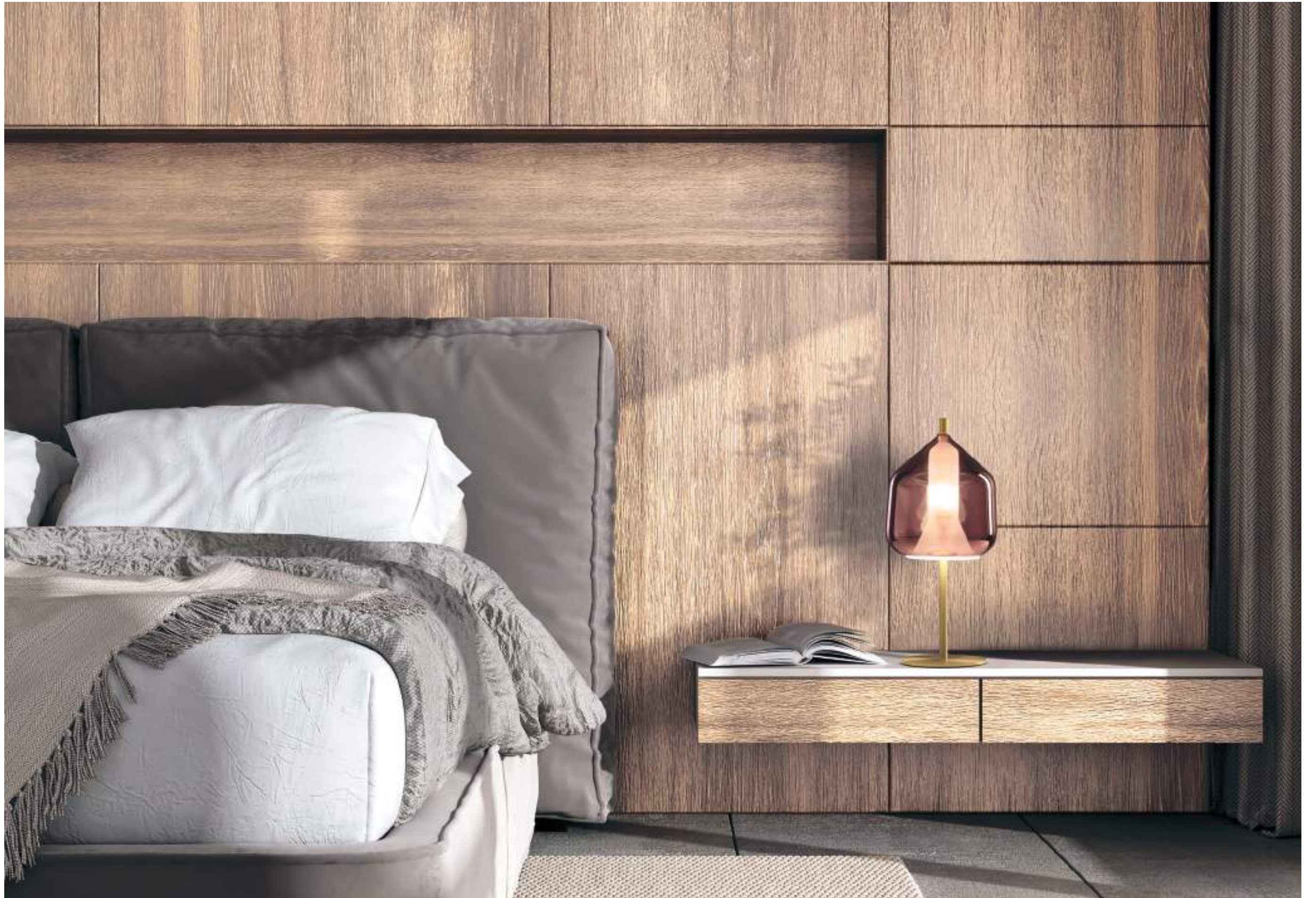

# X-RAY

TABLE





# X-RAY

TABLE



# X-RAY

TABLE





# X-RAY

TABLE



# X-RAY

TABLE



# X-RAY

WALL LAMP



# X-RAY

WALL LAMP







# X-RAY

WALL LAMP



# X-RAY

## SUSPENSION

Lampada a sospensione in vetro borosilicato color bronzo o trasparente, diametro cm 14, altezza cm 20. Stelo e rosone in oro spazzolato. Cavo di alimentazione trasparente 200 cm.

Pendant light in borosilicate glass clear or bronze coloured, measuring 14 cm in diameter and 20 cm in height. Brushed gold finish stem and ceiling canopy. Clear 200 cm. cable.

Pendelleuchte mit Leuchtschirm aus Borosilikatglas, bronzefarben oder transparent, Durchmesser 14 cm, Höhe 20 cm. Pendelrohr und Baldachin, goldfarben, gebürstet. Stromkabel transparent, 200 cm.

Suspension en verre borosilicate couleur bronze ou transparent, diamètre 14 cm, hauteur 20 cm. Tige et rosace finition en or brossé. Câble d'alimentation transparent 200 cm.

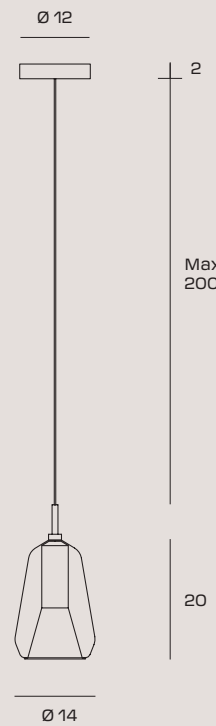

CODE	KIT.M.20	1744.88
GLASS	● Bronze	○ Transparent

### LIGHT SOURCE

G9 LED | 1 x max 10w  
Max bulb size: Ø21xH80mm



# X-RAY

## SUSPENSION

Lampada a sospensione in vetro borosilicato color rame o trasparente, diametro cm 17, altezza cm 18. Stelo e rosone in oro spazzolato. Cavo di alimentazione trasparente 200 cm.

Pendant light in borosilicate glass clear or copper coloured, measuring 17 cm in diameter and 18 cm in height. Brushed gold finish stem and ceiling canopy. Clear 200 cm. cable.

Pendelleuchte mit Leuchtschirm aus Borosilikatglas, kupferfarben oder transparent, Durchmesser 17 cm, Höhe 18 cm. Pendelrohr und Baldachin, goldfarben, gebürstet. Stromkabel transparent, 200 cm.

Suspension en verre borosilicate couleur cuivre ou transparent, diamètre 17 cm, hauteur 18 cm. Tige et rosace finition en or brossé. Câble d'alimentation transparent 200 cm.

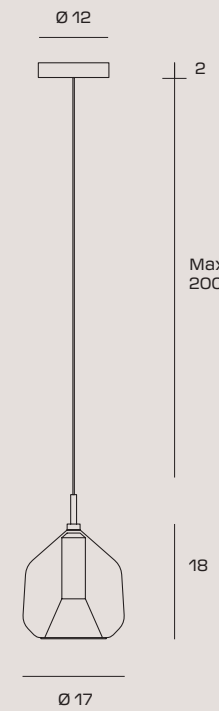

CODE	KIT.M.18	1744.97
GLASS	● Copper	○ Transparent

### LIGHT SOURCE

G9 LED | 1 x max 10w  
Max bulb size: Ø21xH80mm



# X-RAY

## SUSPENSION

Lampada a sospensione in vetro borosilicato color oro o trasparente, diametro cm 20, altezza cm 12. Stelo e rosone in oro spazzolato. Cavo di alimentazione trasparente 200 cm.

Pendant light in borosilicate glass clear or gold coloured, measuring 20 cm in diameter and 12 cm in height. Brushed gold finish stem and ceiling canopy. Clear 200 cm.

Pendelleuchte mit Leuchtschirm aus Borosilikatglas, goldfarben oder transparent, Durchmesser 20 cm, Höhe 12 cm. Pendelrohr und Baldachin, goldfarben, gebürstet. Stromkabel transparent, 200 cm.

Suspension en verre borosilicate couleur or ou transparent, diamètre 20 cm, hauteur 12 cm. Tige et rosace finition en or brossé. Câble d'alimentation transparent 200 cm.

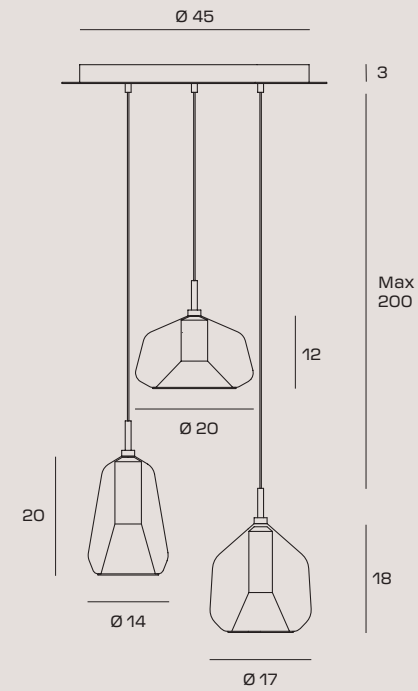

CODE	KIT.M.19	1744.90
GLASS	● Gold	○ Transparent

### LIGHT SOURCE

G9 LED | 1 x max 10w  
Max bulb size: Ø21xH80mm



# X-RAY

## SUSPENSION

Lampada a sospensione a 3 luci in vetro borosilicato. Rosone in oro spazzolato, (diametro cm 45). Cavo di alimentazione trasparente 200 cm. Possibilità di configurare la sospensione con vetri di forme e colore diversi (pg. 510).

3-light pendant in borosilicate glass. Brushed gold finish ceiling canopy (45 cm in diameter). Clear 200 cm. cable. The pendant light can be configured with glass of different colours and shapes (pg. 510).

Pendelleuchte mit 3 Leuchtschirmen aus Borosilikatglas. Baldachin goldfarben, gebürstet, (Durchmesser 45 cm). Stromkabel transparent, 200 cm. Kombinationsmöglichkeit mit verschiedenen Schirmformen und verschiedenen Farben. (pg. 510).

Suspension à 3 lampes en verre borosilicate. Rosace en or brossé, (diamètre 45 cm). Câble d'alimentation transparent 200 cm. Possibilité de configurer la suspension avec des verres de formes et de couleurs différentes (pag. 510).



CODE	1744.107.KIT	KIT.M.7	KIT.M.8	KIT.M.9	KIT.M.10
GLASS	○ Transparent	● Bronze	Multicolor	● Gold	● Copper

### LIGHT SOURCE

G9 LED | 3 x max 10w  
Max bulb size: Ø21xH80mm



# X-RAY

## SUSPENSION

Lampada a sospensione a 6 luci in vetro borosilicato. Stelo e rosone (diametro cm 60) in oro spazzolato. Cavo di alimentazione trasparente 200 cm. Possibilità di configurare la sospensione con vetri di forme e colore diversi. (pg. 510)

6-light pendant in borosilicate glass. Brushed gold finish stem and ceiling canopy (60 cm in diameter). Clear 200 cm. The pendant light can be configured with glass of different colours and shapes. (pg. 510)

Pendelleuchte mit 6 Leuchtschirmen aus Borosilikatglas. Baldachin (Durchmesser 60 cm) goldfarben, gebürstet. Stromkabel transparent, 200 cm. Kombinationsmöglichkeit mit verschiedenen Schirmformen und verschiedenen Farben. (pg.510)

Suspension à 6 lumières en verre borosilicate. Tige et rosace (diamètre 60 cm) en or brossé. Câble d'alimentation transparent 200 cm. Possibilité de configurer la suspension avec des verres de formes et de couleurs différentes. (pag. 510).

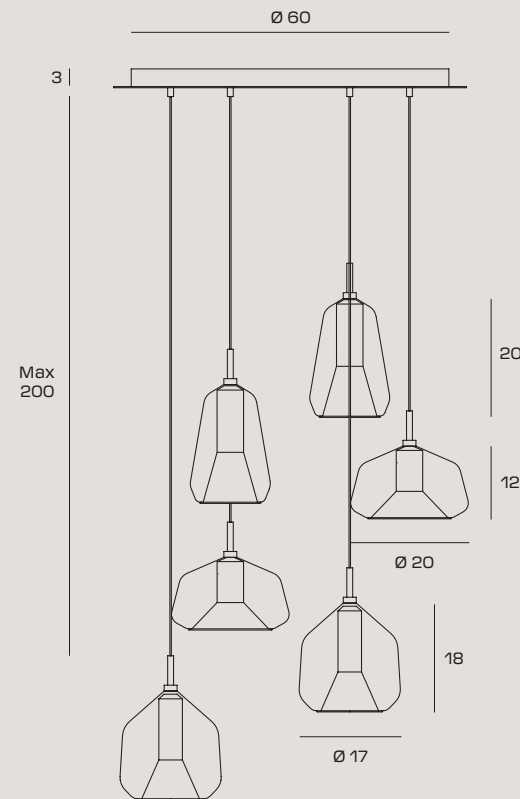

CODE	KIT.M.11	KIT.M.12	KIT.M.13	KIT.M.14
GLASS	Multicolor	Gold	Copper	Bronze

### LIGHT SOURCE

G9 LED | 6 x max 10w  
Max bulb size: Ø21xH80mm



# X-RAY

## SUSPENSION

Lampada a sospensione a 9 luci in vetro borosilicato. Stelo e rosone di cm 90 in oro spazzolato. Cavo di alimentazione trasparente 200 cm. Possibilità di configurare la sospensione con vetri di forme e colore diversi. (pg. 510)

9-light pendant in borosilicate glass. Brushed gold finish stem and 90 cm ceiling canopy. Clear 200 cm. cable. The pendant light can be configured with glass of different colours and shapes. (pg. 510)

Pendelleuchte mit 9 Leuchtschirmen aus Borosilikatglas. Baldachin (Durchmesser 90 cm) goldfarben, gebürstet. Stromkabel transparent, 200 cm. Kombinationsmöglichkeit mit verschiedenen Schirmformen und verschiedenen Farben. (pg. 510)

Suspension à 9 lumières en verre borosilicate. Tige et rosace de 90 cm en or brossé. Câble d'alimentation transparent 200 cm. Possibilité de configurer la suspension avec des verres de formes et de couleurs différentes. (pag. 510).

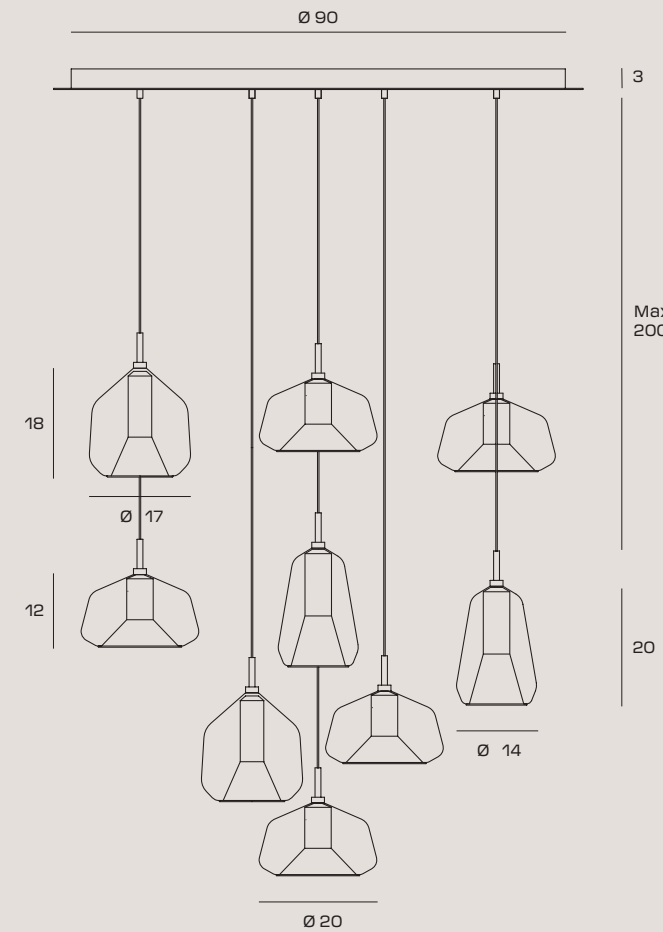

CODE	KIT.M.15	KIT.M.16	KIT.M.17	1744.137.KIT
GLASS	Multicolor	Multicolor	Multicolor	Transparent

### LIGHT SOURCE

G9 LED | 9 x max 10w  
Max bulb size: Ø21xH80mm



# X-RAY

## PERSONALIZZAZIONE X-RAY SOSPENSIONE CUSTOMIZATION FOR X-RAY SUSPENSION LIGHT PERSONALISIERUNG X-RAY PENDELLEUCHTE PERSONNALISATION X-RAY SUSPENSION

Possibilità di configurare la sospensione con vetri in borosilicato di forme e colore diversi.  
Rosone in oro spazzolato per **1, 3, 6 e 9 luci** completo di cavo con portalampada. Cavo di alimentazione trasparente cm 200.



The pendant light can be customised with borosilicate glass of different colours and shapes.  
Brushed gold finish ceiling canopy for **1, 3, 6 and 9 lights** with cable. Transparent 200 cm power cable.



Möglichkeit, die Pendelleuchte mit Borosilikatglas in verschiedenen Formen und Farben zu konfigurieren.  
Rosette in gebürstetem Gold für **1, 3, 6 und 9 Leuchten**, komplett mit Kabel und Lampenhalterung.  
Transparentes Stromkabel 200 cm

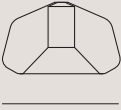

Possibilité de configurer la suspension avec des verres en borosilicate de différentes formes et couleurs.  
Rosace en or brossé pour **1, 3, 6 et 9 points lumineux** avec câble et douilles. Câble d'alimentation transparent 200 cm.

## VETRI/GLASSES/GLAS/VERRE

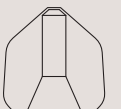
### FORMA/SHAPE/BILDEN/FORME      TRASPARENTE/CLEAR/TRANSPARENT/TRANSPARENT

12			Set composto da vetro interno satinato + vetro esterno <b>trasparente o oro</b> . Set with satin glass inside and <b>clear or gold</b> glass outside. Set mit satiniertem Glas innen + <b>transparentem oder goldfarbenem</b> Glas außen. Ensemble composé d'un verre intérieur satiné + verre extérieur <b>transparent ou or</b> .						
	Ø 20								
			<table border="0" style="width: 100%;"> <tr> <td>CODE</td> <td style="text-align: center;"><b>1744.V.118</b></td> <td style="text-align: center;"><b>1744.V.118.GOLD</b></td> </tr> <tr> <td>GLASS</td> <td style="text-align: center;"><input type="radio"/> Transparent</td> <td style="text-align: center;"><input checked="" type="radio"/> Gold</td> </tr> </table>	CODE	<b>1744.V.118</b>	<b>1744.V.118.GOLD</b>	GLASS	<input type="radio"/> Transparent	<input checked="" type="radio"/> Gold
CODE	<b>1744.V.118</b>	<b>1744.V.118.GOLD</b>							
GLASS	<input type="radio"/> Transparent	<input checked="" type="radio"/> Gold							

18			Set composto da vetro interno satinato + vetro esterno <b>trasparente o rame</b> . Set with satin glass inside and <b>clear or copper</b> glass outside. Set mit satiniertem Glas innen + <b>transparentem oder kupferfarbenem</b> Glas außen. Ensemble composé d'un verre intérieur dépoli + verre extérieur <b>transparent ou cuivre</b> .						
	Ø 17								
			<table border="0" style="width: 100%;"> <tr> <td>CODE</td> <td style="text-align: center;"><b>1744.V.119</b></td> <td style="text-align: center;"><b>1744.V.119.COPPER</b></td> </tr> <tr> <td>GLASS</td> <td style="text-align: center;"><input type="radio"/> Transparent</td> <td style="text-align: center;"><input checked="" type="radio"/> Copper</td> </tr> </table>	CODE	<b>1744.V.119</b>	<b>1744.V.119.COPPER</b>	GLASS	<input type="radio"/> Transparent	<input checked="" type="radio"/> Copper
CODE	<b>1744.V.119</b>	<b>1744.V.119.COPPER</b>							
GLASS	<input type="radio"/> Transparent	<input checked="" type="radio"/> Copper							

20			Set composto da vetro interno satinato + vetro esterno <b>trasparente o bronzo</b> . Set with satin glass inside and <b>clear or bronze</b> glass outside. Set mit satiniertem Glas innen + <b>transparentem oder bronzefarbenem</b> Glas außen. Ensemble composé d'un verre intérieur dépoli + verre extérieur <b>transparent ou bronze</b> .						
	Ø 14								
			<table border="0" style="width: 100%;"> <tr> <td>CODE</td> <td style="text-align: center;"><b>1744.V.120</b></td> <td style="text-align: center;"><b>1744.V.120.BRONZE</b></td> </tr> <tr> <td>GLASS</td> <td style="text-align: center;"><input type="radio"/> Transparent</td> <td style="text-align: center;"><input checked="" type="radio"/> Bronze</td> </tr> </table>	CODE	<b>1744.V.120</b>	<b>1744.V.120.BRONZE</b>	GLASS	<input type="radio"/> Transparent	<input checked="" type="radio"/> Bronze
CODE	<b>1744.V.120</b>	<b>1744.V.120.BRONZE</b>							
GLASS	<input type="radio"/> Transparent	<input checked="" type="radio"/> Bronze							

## ROSONI A SOFFITTO CEILING CANOPY DECKENLAMPEN ROSACES DE PLAFOND

Rosone per sospensioni a **1 luce** completo di cavi e portalampada G9 (lunghezza max 200 cm) Ø cm 12.  
Ceiling canopy for pendant lamp with **1 light**, supplied with cables and lamp holder G9 (mx length: 200 cm) Ø cm 12.  
Rosette für **1 Pendelleuchte**, inklusive Kabel mit Fassungen G9 (Länge max. 200 cm) Ø cm 12.  
Rosace pour suspension à **1 lumière** avec câbles et douilles G9 (longueur max 200 cm) Ø cm 12.

Ø 12



CODE      **1744.M.187**

Rosone per sospensioni a **3 luci** completo di cavi e portalampada G9 (lunghezza max 200 cm) Ø cm 45.  
Ceiling canopy for pendant lamp with **3 lights**, supplied with cables and lamp holder G9 (mx length: 200 cm) Ø cm 45.  
Rosette für **3 Pendelleuchten**, inklusive Kabel mit Fassungen G9 (Länge max. 200 cm) Ø cm 45.  
Rosace pour suspension à **3 lumières** avec câbles et douilles G9 (longueur max 200 cm) Ø cm 45.

Ø 45

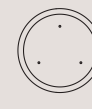

CODE      **1744.M.131**

Rosone per sospensioni a **6 luci** completo di cavi e portalampada G9 (lunghezza max 200 cm) Ø cm 60.  
Ceiling canopy for pendant lamp with **6 lights**, supplied with cables and lamp holder G9 (mx length: 200 cm) Ø cm 60.  
Rosette für **6 Pendelleuchten**, inklusive Kabel mit Fassungen G9 (Länge max. 200 cm) Ø cm 60.  
Rosace pour suspension à **6 lumières** avec câbles et douilles (longueur max 200 cm) Ø cm 60.

Ø 60

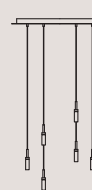

CODE      **1744.M.132**

Rosone per sospensioni a **9 luci** completo di cavi e portalampada G9 (lunghezza max 200 cm) Ø cm 90.  
Ceiling canopy for pendant lamp with **9 lights**, supplied with cables and lamp holder G9 (mx length: 200 cm) Ø cm 90.  
Rosette für **9 Pendelleuchten**, inklusive Kabel mit Fassungen G9 (Länge max. 200 cm) Ø cm 90.  
Rosace pour suspension à **9 lumières** avec câbles et douilles G9 (longueur max 200 cm) Ø cm 90.

Ø 90



CODE      **1744.M.133**

# X-RAY

## TABLE

Lampada da tavolo in vetro borosilicato color bronzo o trasparente. Montatura in oro spazzolato, altezza lampada cm 39, vetro diametro cm 14. Cavo di alimentazione trasparente con dimmer.

Table lamp in borosilicate glass, clear or bronze coloured. Brushed gold finish body, lamp height 39 cm, 14 cm diameter glass. Clear cable with dimmer switch.

Tischleuchte mit Leuchtschirm aus Borosilikatglas, bronzefarben oder transparent. Standfuß goldfarben, gebürstet, Tischleuchtenhöhe 39 cm, Leuchtschirmdurchmesser 14 cm. Stromkabel transparent mit Dimmer.

Lampe de table en verre borosilicate couleur bronze ou transparent. Cadre finition en or brossé, hauteur lampe 39 cm, verre diamètre 14 cm. Câble d'alimentation transparent avec variateur.

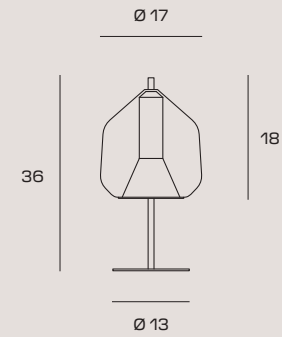
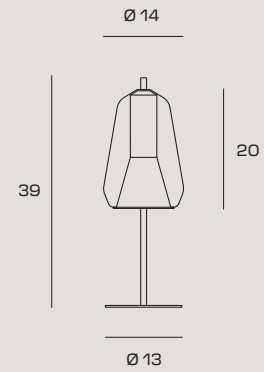

CODE	KIT.M.1	1744.146.KIT
GLASS	<span style="color: #8B4513;">●</span> Bronze	<span style="color: #A9A9A9;">○</span> Transparent

### LIGHT SOURCE

 G9 LED DIMMABLE | 1 x max 10w  
Max bulb size: Ø21xH80mm



# X-RAY

## TABLE

Lampada da tavolo in vetro borosilicato color rame o trasparente. Montatura in oro spazzolato, altezza lampada cm 36, vetro diametro cm 17. Cavo di alimentazione trasparente con dimmer.

Table lamp in borosilicate glass, clear or copper coloured. Brushed gold finish body, lamp height 36 cm, 17 cm diameter glass. Clear cable with dimmer switch.

Tischleuchte mit Leuchtschirm aus Borosilikatglas, Himmelblau oder kupferfarben. Standfuß goldfarben, gebürstet, Tischleuchtenhöhe 36cm, Leuchtschirmdurchmesser 17 cm. Stromkabel transparent mit Dimmer.

Lampe de table en verre borosilicate couleur cuivre ou transparent. Cadre finition en or brossé, hauteur lampe 36 cm, verre diamètre 17 cm. Câble d'alimentation transparent avec variateur.



CODE	KIT.M.2	1744.121.KIT
GLASS	<span style="color: #8B4513;">●</span> Copper	<span style="color: #A9A9A9;">○</span> Transparent

### LIGHT SOURCE

 G9 LED DIMMABLE | 1 x max 10w  
Max bulb size: Ø21xH80mm



# X-RAY

## TABLE

Lampada da tavolo in vetro borosilicato color oro o trasparente. Montatura in oro spazzolato, altezza lampada cm 36, vetro diametro cm 20. Cavo di alimentazione trasparente con dimmer.

Table lamp in borosilicate glass, clear or gold coloured. Brushed gold finish body, lamp height 36 cm, 20 cm diameter glass. Clear cable with dimmer switch.

Tischleuchte mit Leuchtschirm aus Borosilikatglas, goldfarben oder transparent. Standfuß goldfarben, gebürstet. Tischleuchtenhöhe 36 cm, Leuchtschirmdurchmesser 20 cm. Stromkabel transparent mit Dimmer.

Lampe de table en verre borosilicate couleur or ou transparent. Cadre finition en or brossé, hauteur lampe 36 cm, verre diamètre 20 cm. Câble d'alimentation transparent avec variateur.

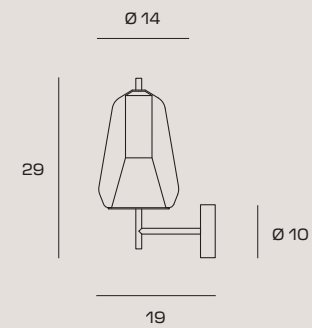
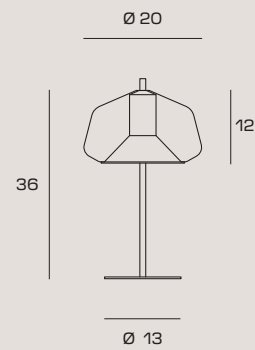

# X-RAY

## WALL LAMP

Lampada da parete in vetro borosilicato color bronzo o trasparente. Vetro diametro cm 14, altezza totale cm 29. Montatura in oro spazzolato.

Wall light in borosilicate glass clear or bronze coloured. Glass measuring 14 cm in diameter, total height 29 cm. Brushed gold finish body.

Wandleuchte mit Leuchtschirm aus Borosilikatglas in bronzefarben oder transparent. Leuchtschirmdurchmesser 14 cm, Gesamthöhe 29 cm. Halterung goldfarben, gebürstet.

Applique en verre borosilicate couleur bronze ou transparent. Verre diamètre 14 cm, hauteur totale 29 cm. Cadre finition en or brossé.



CODE	KIT.M.3	1744.145.KIT
GLASS	● Gold	○ Transparent

### LIGHT SOURCE

G9 LED DIMMABLE | 1 x max 10w  
Max bulb size: Ø21xH80mm



CODE	KIT.M.4	1744.120.KIT
GLASS	● Bronze	○ Transparent

### LIGHT SOURCE

G9 LED | 1 x max 10w  
Max bulb size: Ø21xH80mm



# X-RAY

## WALL LAMP

Lampada da parete in vetro borosilicato color rame o trasparente. Vetro diametro cm 17, altezza totale cm 27,5. Montatura in oro spazzolato.

Wall light in borosilicate glass clear or copper coloured. Glass measuring 17 cm in diameter, total height 27,5 cm. Brushed gold finish body.

Wandleuchte mit Leuchtschirm aus Borosilikatglas in kupferfarben oder transparent. Leuchtschirmdurchmesser 17 cm, Gesamthöhe 27,5 cm. Halterung goldfarben, gebürstet.

Applique en verre borosilicate couleur cuivre ou transparent. Verre diamètre 17 cm, hauteur totale 27,5 cm. Cadre avec finition en or brossé.

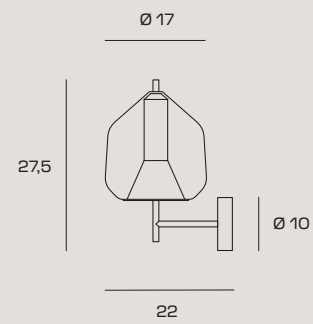

CODE	KIT.M.6	1744.118.KIT
GLASS	<span style="color: #C8513E;">●</span> Copper	<span style="color: #A9A9A9;">○</span> Transparent

### LIGHT SOURCE

 G9 LED | 1 x max 10w  
Max bulb size: Ø21xH80mm

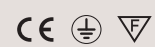

# X-RAY

## WALL LAMP

Lampada da parete in vetro borosilicato color oro o trasparente. Vetro diametro cm 20, altezza totale cm 20. Montatura in oro spazzolato.

Wall light in borosilicate glass clear or gold coloured. Glass measuring 20 cm in diameter, total height 20 cm. Brushed gold finish body.

Wandleuchte mit Leuchtschirm aus Borosilikatglas goldfarben oder transparent. Leuchtschirmdurchmesser 20 cm, Gesamthöhe 20 cm. Halterung goldfarben, gebürstet.

Applique en verre borosilicate couleur or ou transparent. Verre diamètre 20 cm, hauteur totale 20 cm. Cadre avec finition en or brossé.

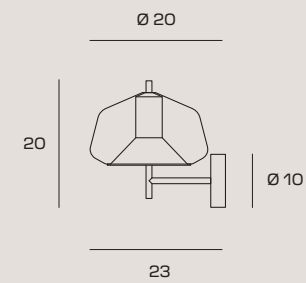

CODE	KIT.M.5	1744.119.KIT
GLASS	<span style="color: #D4AF37;">●</span> Gold	<span style="color: #A9A9A9;">○</span> Transparent

### LIGHT SOURCE

 G9 LED | 1 x max 10w  
Max bulb size: Ø21xH80mm





JOTTO

## JOTTO

La forza di calarsi in ogni contesto, l'originalità di essere senza paragoni. La forma sferica di Jotto fa sì che possa inserirsi facilmente in ogni ambiente mentre il supporto in acciaio spazzolato in cui la sfera è incastonata, grazie al tocco tecnico e severo dato dalla doppia inclinazione, la rende unica e chiaramente distinguibile. Collocate nello stesso ambiente, le molteplici identità di Jotto creano coerenza e continuità.

The strength to fit into any context, the originality to be unparalleled. Jotto's spherical shape means that it can fit easily into any environment, while the brushed steel support in which the sphere is set, through the technical and severe touch given by the double inclination, makes it unique and clearly distinguishable. Placed in the same environment, Jotto's multiple identities create coherence and continuity.

Die Stärke, sich in jeden Kontext einzufügen, die Originalität, unvergleichlich zu sein. Dank seiner Kugelform passt Jotto in jede Umgebung, während die Halterung aus gebürstetem Stahl, in die die Kugel eingelassen ist, dank der technischen und strengen Note, die durch die doppelte Neigung gegeben ist, einzigartig und deutlich unterscheidbar ist. Die verschiedenen Identitäten von Jotto in ein und demselben Ambiente schaffen Kohärenz und Kontinuität.

Le pouvoir de s'intégrer à n'importe quel contexte, l'originalité d'être sans équivalent. La forme sphérique de Jotto lui permet de s'intégrer aisément à n'importe quel environnement, tandis que le support en acier brossé qui enserme la sphère ajoute une touche technique stricte, créée par la double inclinaison, qui en fait un objet unique et tout à fait distinctif. Placées dans le même environnement, les multiples identités de Jotto créent cohérence et continuité.

# JOTTO

SUSPENSION







# JOTTO

SUSPENSION



# JOTTO

SUSPENSION



# JOTTO

SUSPENSION



# JOTTO

TABLE



# JOTTO

TABLE







# JOTTO

CEILING LAMP

# JOTTO

CEILING LAMP



# JOTTO

FLOOR LAMP



# JOTTO

## SUSPENSION

Lampada a sospensione  
in metallo spazzolato alluminio,  
vetro Pyrex trasparente  
con sfumatura Ambra diam. 15cm.

Pendant lamp  
in brushed aluminium metal,  
transparent Pyrex glass with  
Amber nuance. Diameter: 15cm.

Pendelleuchte aus gebürstetem  
Metall und Aluminium,  
transparentes Pyrexglas  
mit bernsteinfarbener  
Schattierung Durchm. 15cm.

Suspension  
en aluminium brossé,  
verre Pyrex transparent  
avec abat-jour Ambre diam. 15 cm.

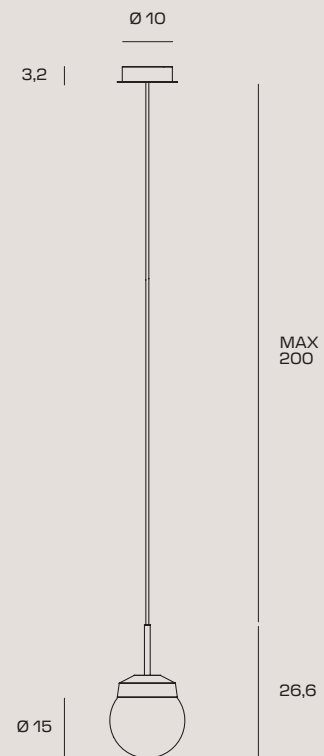

CODE	KIT.M.25
COLOR	● Brushed Steel

### LIGHT SOURCE

 Source GX53 LED | Power 1 x max 10w



# JOTTO

## SUSPENSION

Lampada a sospensione  
in metallo spazzolato alluminio,  
vetro Pyrex trasparente  
con sfumatura Ambra diam. 25cm.

Pendant lamp  
in brushed aluminium metal,  
transparent Pyrex glass with  
Amber nuance. Diameter: 25cm.

Pendelleuchte aus gebürstetem  
Metall und Aluminium,  
transparentes Pyrexglas  
mit bernsteinfarbener  
Schattierung Durchm. 25cm.

Suspension  
en aluminium brossé,  
verre Pyrex transparent  
avec abat-jour Ambre diam. 25 cm.

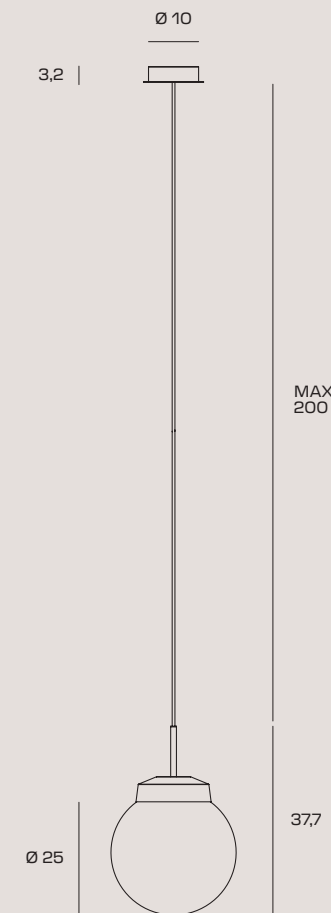

CODE	KIT.M.26
COLOR	● Brushed Steel

### LIGHT SOURCE

 Source GX53 LED | Power 1 x max 10w

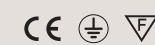

# JOTTO

## SUSPENSION

Lampada a sospensione con tre vetri: due diam.15 e uno diam. 25.  
Rosone Bianco opaco, vetri borosilicato trasparente sfumati ambra e struttura acciaio spazzolato.  
Rosone lineare verniciato bianco opaco 74x 9 cm.

Pendant lamp with three glass panes: diameter: 2 x 15cm and 1 x 25cm.  
Matte White ceiling canopy, transparent borosilicate glass with amber nuances, and brushed steel structure.  
Matte white painted linear ceiling canopy, 74x 9 cm.

Hängeleuchte mit drei Glasscheiben: zwei Durchm. 15 und eine Durchm. 25.  
Opak-weiße Rosette, transparentes, bernsteinfarbenes Borosilikatglas und Struktur aus gebürstetem Stahl.  
Lineare Rosette mattweiß lackiert 74x 9 cm.

Suspension trois verres : deux diam. 15 et un diam. 25.  
Rosace blanc mat, verre borosilicate transparent ambré et structure en acier brossé.  
Rosace linéaire peinte blanc mat 74x 9 cm.

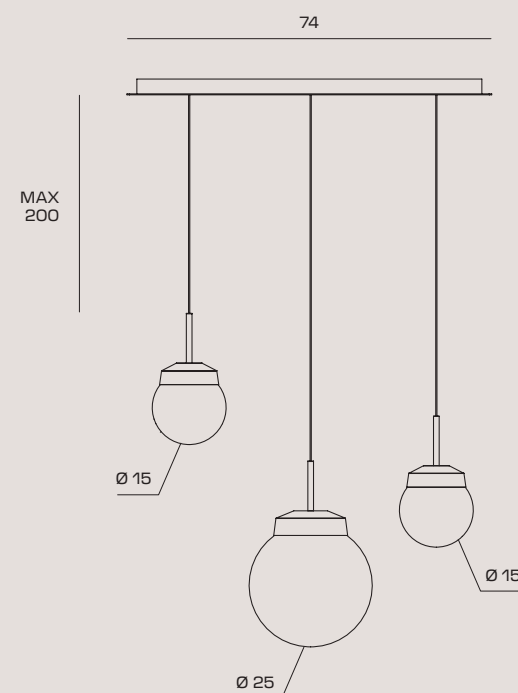

CODE	KIT.M.21
COLOR	● Brushed Steel

### LIGHT SOURCE

 Source GX53 LED | Power 3 x max 10w



# JOTTO

## SUSPENSION

Lampada a sospensione con tre vetri: uno diam.15 e due diam. 25.  
Rosone Bianco opaco, vetri borosilicato trasparente sfumati ambra e struttura acciaio spazzolato.  
Rosone lineare verniciato bianco opaco 74x 9 cm.

Pendant lamp with three glass panes: diameter: 1 x 15cm and 1 x 25cm.  
Matte White ceiling canopy, transparent borosilicate glass with amber nuances, and brushed steel structure.  
Matte white painted linear ceiling canopy, 74x 9 cm.

Hängeleuchte mit drei Glasscheiben: eine Durchm. 15 und zwei Durchm. 25.  
Opak-weiße Rosette, transparentes, bernsteinfarbenes Borosilikatglas und Struktur aus gebürstetem Stahl.  
Lineare Rosette mattweiß lackiert 74x 9 cm.

Suspension trois verres : un diam. 15 et deux diam. 25.  
Rosace blanc mat, verre borosilicate transparent ambré et structure en acier brossé.  
Rosace linéaire peinte blanc mat 74x 9 cm.

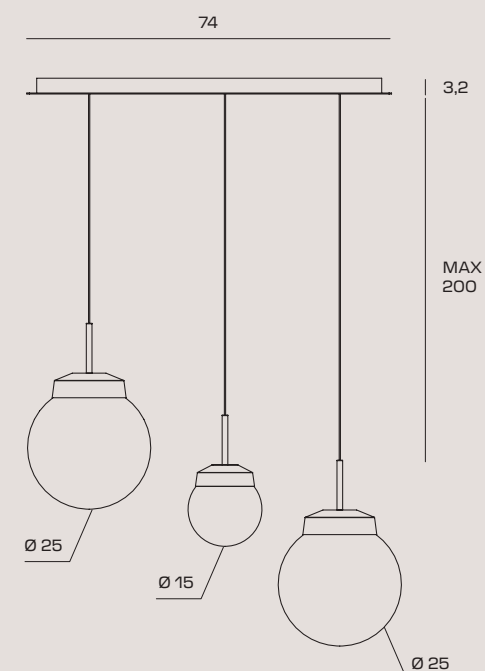

CODE	KIT.M.22
COLOR	● Brushed Steel

### LIGHT SOURCE

 Source GX53 LED | Power 3 x max 10w



# JOTTO

## SUSPENSION

Lampada a sospensione con tre vetri diam. 15.  
Rosone Bianco opaco, vetri borosilicato trasparente sfumati ambra e struttura acciaio spazzolato.  
Rosone lineare verniciato bianco opaco 74x 9 cm.

Pendant lamp with three glass panes.  
Diameter: 15cm.  
Matte White ceiling canopy, transparent borosilicate glass with amber nuances, and brushed steel structure.  
Matte white painted linear ceiling canopy 74x 9 cm.

Hängeleuchte mit drei Glasscheiben Durchm. 15.  
Opak-weiße Rosette, transparentes, bernsteinfarbendes Borosilikatglas und Struktur aus gebürstetem Stahl.  
Lineare Rosette mattweiß lackiert 74x 9 cm.

Suspension trois verres diam. 15.  
Rosace blanc mat, verre borosilicate transparent ambré et structure en acier brossé.  
Rosace linéaire peinte blanc mat 74x 9 cm.

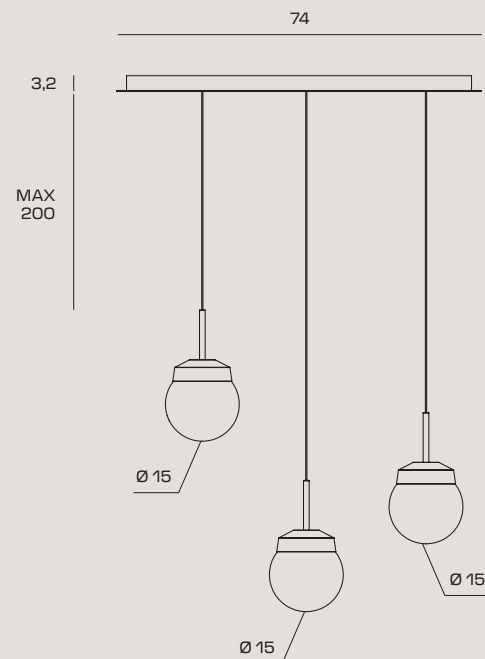

CODE	KIT.M.23
COLOR	● Brushed Steel

### LIGHT SOURCE

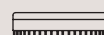
 Source GX53 LED | Power 3 x max 10w



# JOTTO

## SUSPENSION

Lampada a sospensione con tre vetri diam. 25.  
Rosone Bianco opaco, vetri borosilicato trasparente sfumati ambra e struttura acciaio spazzolato.  
Rosone lineare verniciato bianco opaco 74x 9 cm.

Pendant lamp with three glass panes, diameter: 3 x 25cm.  
Matte White ceiling canopy, transparent borosilicate glass with amber nuances, and brushed steel structure.  
Matte white painted linear ceiling canopy, 74x 9 cm.

Hängeleuchte mit drei Glasscheiben Durchm. 25.  
Opak-weiße Rosette, transparentes, bernsteinfarbendes Borosilikatglas und Struktur aus gebürstetem Stahl.  
Lineare Rosette mattweiß lackiert 74x 9 cm.

Suspension trois verres diam. 25.  
Rosace blanc mat, verre borosilicate transparent ambré et structure en acier brossé.  
Rosace linéaire peinte blanc mat 74x 9 cm.

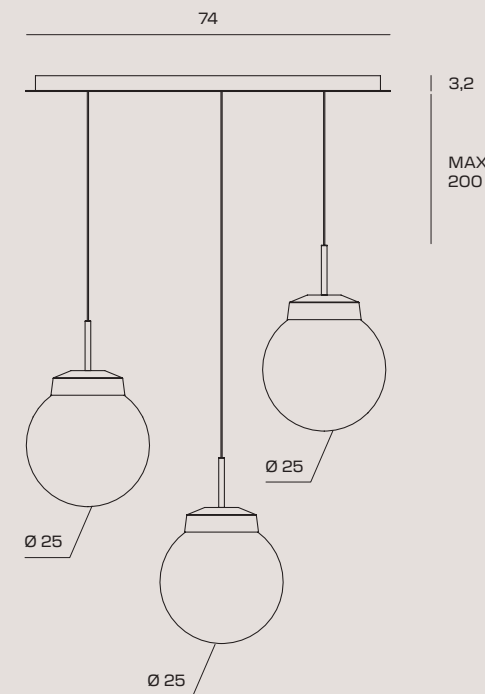

CODE	KIT.M.24
COLOR	● Brushed Steel

### LIGHT SOURCE

 Source GX53 LED | Power 1 x max 10w



# JOTTO

## TABLE

Lampada da tavolo  
in metallo spazzolato alluminio,  
vetro Pirex trasparente  
con sfumatura Ambra diam. 15cm.  
Dotata di dimmer.

Table lamp,  
in brushed aluminium metal,  
transparent Pyrex glass with  
Amber nuance. Diameter: 15cm.  
Dimmerable.

Tischlampe  
aus gebürstetem Aluminium,  
transparentes Pyrexglas mit  
bernsteinfarbener Schattierung  
Durchm. 15cm.  
Ausgestattet mit Dimmer.

Lampe de table  
en aluminium brossé,  
verre Pyrex transparent avec  
abat-jour Ambre diam. 15 cm.  
Avec variateur.

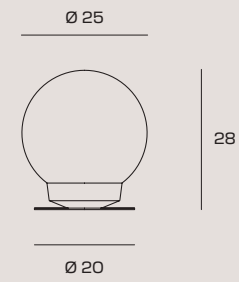

# JOTTO

## TABLE

Lampada da tavolo  
in metallo spazzolato alluminio,  
vetro Pirex trasparente  
con sfumatura Ambra diam. 25cm.  
Dotata di dimmer.

Table lamp,  
in brushed aluminium metal,  
transparent Pyrex glass with  
Amber nuance. Diameter: 25cm.  
Dimmerable.

Tischleuchte aus  
gebürstetem Aluminium,  
transparentes Pyrexglas mit  
bernsteinfarbener Schattierung  
Durchm. 25cm.  
Ausgestattet mit Dimmer.

Lampe de table  
en aluminium brossé,  
verre Pyrex transparent avec  
abat-jour Ambre diam. 25 cm.  
Avec variateur.

CODE	1744.354
COLOR	● Brushed Steel

### LIGHT SOURCE

 Source GX53 LED DIMMABLE | Power 1 x max 10w



CODE	1744.355
COLOR	● Brushed Steel

### LIGHT SOURCE

 Source GX53 LED DIMMABLE | Power 1 x max 10w



# JOTTO

## TABLE

Lampada da tavolo a doppia emissione.  
Portalampada in metallo spazzolato alluminio.  
Diffusore in vetro Pirex trasparente con sfumatura  
Ambra diam. 25cm e base in vetro Pirex trasparente.  
Dotata di dimmer.

Dual-emission table lamp.  
Brushed aluminium metal lamp holder.  
Transparent Pyrex glass diffuser with  
Amber nuances (25cm diameter) and  
transparent Pyrex glass base. Dimmerable.

Tischleuchte mit doppeltem Lichtaustritt.  
Lampenfassung aus gebürstetem Aluminium.  
Diffusor aus transparentem Pyrexglas mit  
bernsteinfarbener Schattierung Durchm. 25 cm  
und transparenter Pyrex-Glasboden.  
Ausgestattet mit Dimmer.

Lampe de table double émission.  
Porte-lampe en aluminium brossé,  
Diffuseur en verre Pyrex transparent  
avec abat-jour ambré diam. 25 cm  
et base en verre Pyrex transparent.  
Avec variateur.

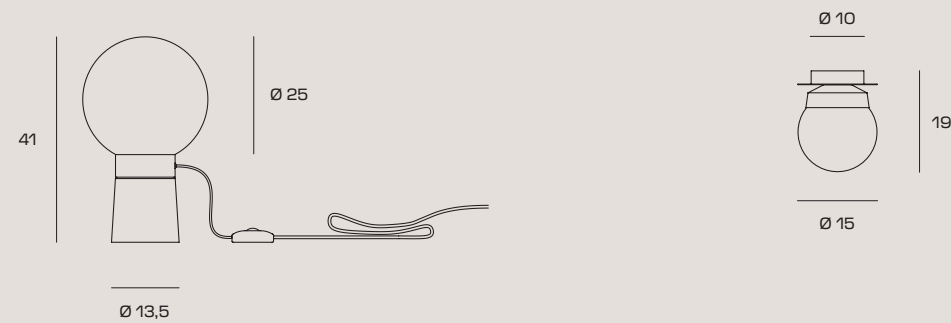

CODE	1744.357
COLOR	● Brushed Steel

### LIGHT SOURCE

 Source GX53 LED DIMMABLE | Power 2 x max 10w

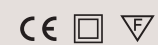

# JOTTO

## CEILING LAMP

Lampada da soffitto  
in metallo spazzolato alluminio,  
vetro Pirex trasparente  
con sfumatura Ambra diam. 15cm.

Ceiling lamp  
in brushed aluminium metal,  
transparent Pyrex glass with  
Amber nuance. Diameter: 15cm.

Deckenleuchte aus  
gebürstetem Aluminium,  
transparentes Pyrexglas  
mit bernsteinfarbener  
Schattierung Durchm. 15cm.

Plafonnier  
en aluminium brossé,  
verre Pyrex transparent avec  
abat-jour Ambre diam. 15 cm.

CODE	1744.359
COLOR	● Brushed Steel

### LIGHT SOURCE

 Source GX53 LED | Power 1 x max 10w



# JOTTO

## CEILING LAMP

Lampada da soffitto  
in metallo spazzolato alluminio,  
vetro Pirex trasparente  
con sfumatura Ambra diam. 25cm.

Ceiling lamp  
in brushed aluminium metal,  
transparent Pyrex glass with  
Amber nuance. Diameter: 25cm.

Deckenleuchte aus gebürstetem  
Aluminium, transparentes Pyrexglas  
mit bernsteinfarbener  
Schattierung Durchm. 25cm.

Plafonnier  
en aluminium brossé,  
verre Pyrex transparent avec  
abat-jour Ambre diam. 25 cm.

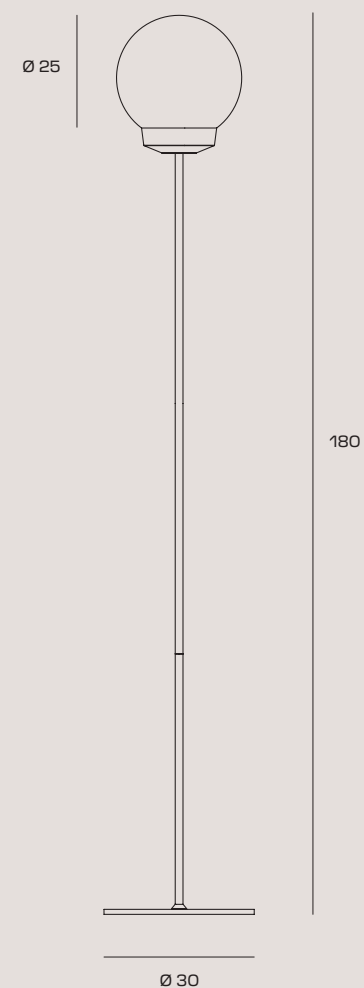
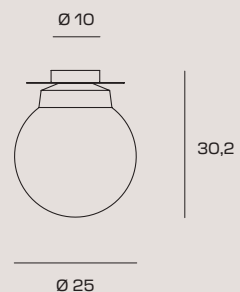

# JOTTO

## FLOOR LAMP

Lampada da terra  
in metallo spazzolato alluminio,  
vetro Pirex trasparente  
con sfumatura Ambra diam. 25cm.  
Dotata di dimmer.

Floor lamp,  
in brushed aluminium metal,  
transparent Pyrex glass with  
Amber nuance. Diameter: 25cm.  
Dimmerable.

Stehleuchte aus gebürstetem  
Aluminium, transparentes Pyrexglas  
mit bernsteinfarbener  
Schattierung Durchm. 25cm.  
Ausgestattet mit Dimmer.

Lampadaire  
en aluminium brossé,  
verre Pyrex transparent avec  
abat-jour Ambre diam. 25 cm.  
Avec variateur.

CODE	1744.352
COLOR	● Brushed Steel

### LIGHT SOURCE

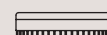
 Source GX53 LED | Power 1 x max 10w



CODE	1744.356
COLOR	● Brushed Steel

### LIGHT SOURCE

 Source GX53 LED DIMMABLE | Power 1 x max 10w





# EBE E ADONE

## EBE E ADONE

Estetica differente, anima complementare. Ebe e Adone: l'una il completamento dell'altra. La prima propone una forma lineare, una classica lanterna in vetro trasparente o grigio fumè all'interno della quale vive il punto luce; la seconda mostra uno stile più barocco e avvolge la sorgente luminosa in una silhouette sinuosa ed accattivante in vetro trasparente o color miele. Originali se scelte singolarmente, affascinanti se abbinate tra loro.

Different aesthetics, complementary souls. Ebe and Adone, one the completion of the other. The first features a linear form, a classic clear glass or smoky grey lantern, housing the spotlight; the second one shows a more baroque style and envelops the spotlight in a sinuous and captivating transparent glass or honey silhouette. Original alone, fascinating when combined.

Unterschiedliche Ästhetik, komplementäre Seele. Ebe und Adone: die eine die Vollendung der anderen. Die erste bietet eine geradlinige Form, eine klassische Laterne aus transparentem oder rauchgrauem Glas, in der sich der Lichtpunkt befindet; die zweite zeigt einen eher barocken Stil und hüllt die Lichtquelle in eine gewundene und fesselnde Silhouette aus transparentem oder honigfarbenem Glas. Originell, wenn sie einzeln gewählt werden, faszinierend, wenn sie kombiniert werden.

Esthétique différente, âme complémentaire. Hébé et Adonis : l'un est le complément de l'autre. La première propose une forme linéaire, avec une lanterne classique en verre transparent ou gris fumé renfermant le point lumineux ; la seconde arbore un style plus baroque et entoure la source lumineuse d'une silhouette sinueuse et fascinante en verre transparent ou couleur miel. Originales prises séparément, fascinantes si on les associe.

# EBE

SUSPENSION





EBE  
SUSPENSION



# EBE

SUSPENSION



# EBE

## SUSPENSION

Lampada a sospensione con diffusore in vetro trasparente o fumé grigio. Cavo elettrico rivestito con guaina in tessuto nero di cm 200. Rosone in oro spazzolato diametro cm 8.

Pendant lamp with transparent glass or smoky grey diffuser. 200 cm black fabric-covered power cable. Brushed gold finish ceiling canopy, diameter 8 cm.

Hängeleuchte mit transparentem oder rauchgrauem Glasdiffusor. Stromkabel ummantelt mit schwarzem Textil, 200 cm. Baldachin goldfarben, gebürstet, mit Durchmesser 8 cm.

Suspension avec diffuseur en verre transparent ou gris fumé. Câble électrique de 200 cm gainé en tissu noir. Rosace en or brossé de 8 cm de diamètre.



CODE	1744.12	1744.13
GLASS	○ Transparent	● Smoke Grey

### LIGHT SOURCE

Source E27 LED | Power 1 x max 20w  
Max bulb size: Ø102xH150mm



# EBE

## SUSPENSION

Lampada con rosone rettangolare Bianco di cm.70 composta da 3 vetri trasparenti o fumé grigio. Cavi di alimentazione tessuto nero di massimo 2 metri di altezza, portalamada Oro spazzolato. Lampadine attacco E27 LED.

Suspension lamp with rectangular white ceiling canopy, 70 cm, composed of 3 transparent or smoked grey glass panels. Black woven power cables up to 2 metre high, brushed gold lamp holder. E27 Led bulbs.

Pendelleuchte mit rechteckiger weißer Rosette von cm.70 bestehend aus 3 transparenten oder rauchgrauen Gläsern. Schwarze, geflochtene Stromkabel mit einer Höhe von bis zu 2 Metern, gebürstete goldene Lampenfassung. E27 Led-Glühbirnen.

Suspension avec rosace blanche rectangulaire de 70 cm composée de 3 verres transparents ou gris fumé. Câbles d'alimentation en tissu noir hauteur max. 2 m, douille en or brossé. Ampoules Led E27.

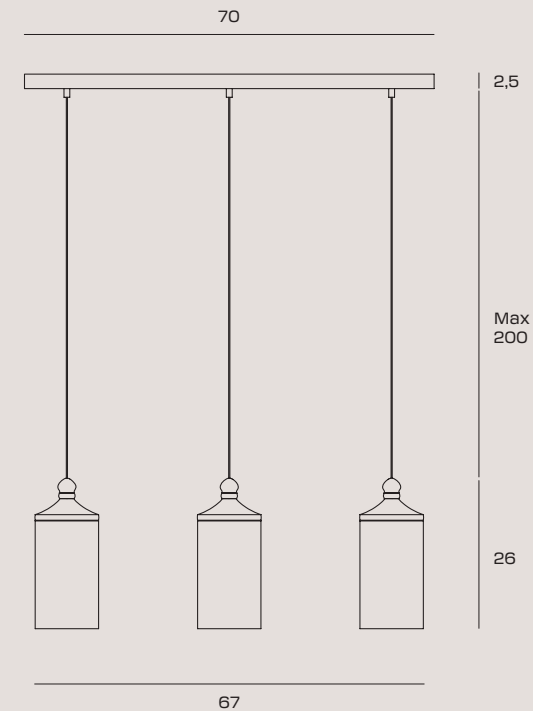
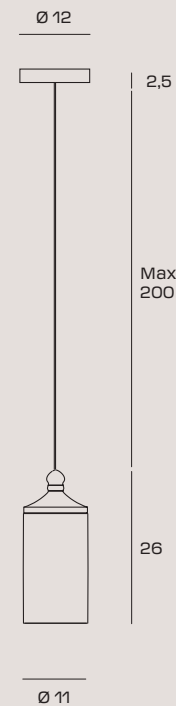

CODE	1744.235.KIT	1744.236.KIT
GLASS	○ Transparent	● Smoke Grey

### LIGHT SOURCE

Source E27 LED | Power 3 x max 20w  
Max bulb size: Ø102xH150mm





# ADONE

SUSPENSION



# ADONE

SUSPENSION





# ADONE

SUSPENSION

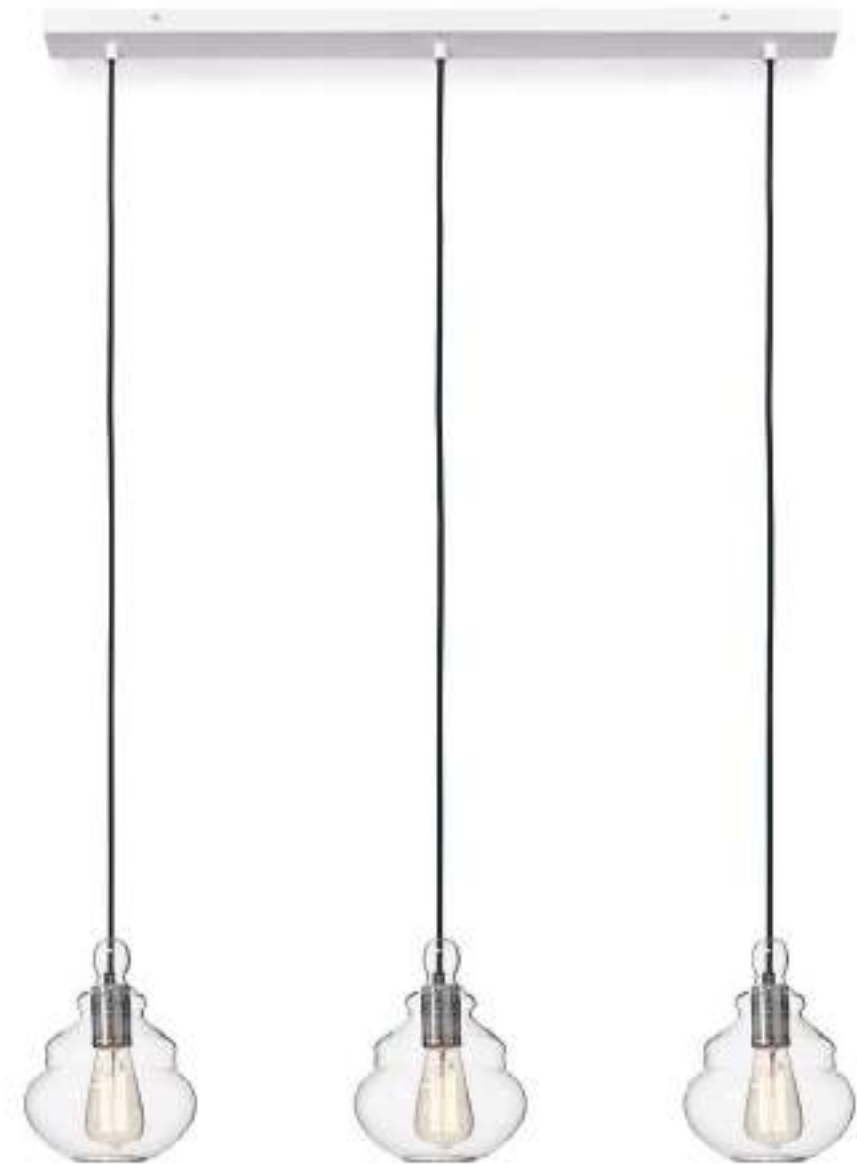

# ADONE

## SUSPENSION

Lampada a sospensione con diffusore in vetro trasparente o color miele. Cavo elettrico rivestito con guaina in tessuto nero di cm 200. Rosone in oro spazzolato diametro cm 8.

Pendant lamp with transparent glass transparent glass or honey silhouette. 200 cm black fabric-covered power cable. Brushed gold finish ceiling canopy, diameter 8 cm.

Hängeleuchte mit transparentem oder honigfarbenem Glasdiffusor. Stromkabel ummantelt mit schwarzem Textil, 200 cm. Baldachin goldfarben, gebürstet, mit Durchmesser 8 cm.

Suspension avec diffuseur en verre transparent ou couleur miel. Câble électrique de 200 cm gainé en tissu noir. Rosace en or brossé de 8 cm de diamètre.



CODE	1744.14	1744.15
GLASS	○ Transparent	● Honey

### LIGHT SOURCE

Source E27 LED | Power 1 x max 20w  
Max bulb size: Ø102xH150mm



# ADONE

## SUSPENSION

Lampada con rosone rettangolare Bianco di cm.70 composta da 3 vetri trasparenti o color miele. Cavi di alimentazione tessuto nero di massimo 2 metri di altezza, portalampana Cromo lucido. Lampadine attacco E27 LED.

Suspension lamp with rectangular white ceiling canopy of cm.70 composed of 3 transparent or honey-coloured glass panes. Black fabric power cables of maximum 2 metres in height, polished chrome lamp holder. E27 Led bulbs.

Pendelleuchte mit rechteckiger weißer Rosette von cm.70 bestehend aus 3 transparenten oder bernsteinfarbenen Gläsern. Schwarze Stromkabel aus Stoff mit einer maximalen Höhe von 2 Metern, polierte Chromfassung. E27 Led-Glühbirnen.

Suspension avec rosace blanche rectangulaire de 70 cm composée de 3 verres transparents ou couleur miel. Câbles d'alimentation en tissu noir hauteur max. 2 m, douille en chrome poli. Ampoules Led E27.

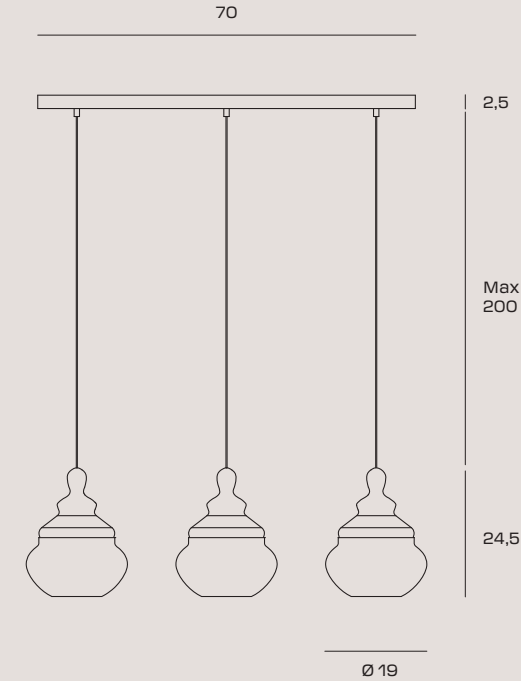
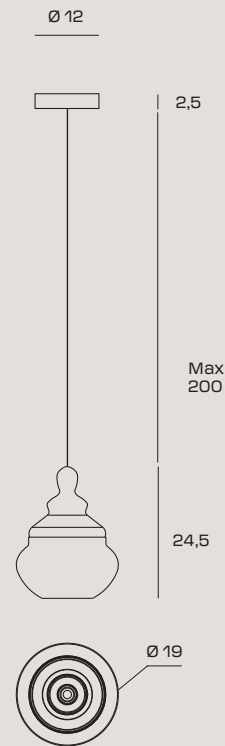

CODE	1744.237.KIT	1744.238.KIT
GLASS	○ Transparent	● Honey

### LIGHT SOURCE

Source E27 LED | Power 3 x max 20w  
Max bulb size: Ø102xH150mm



# EBE+ ADONE

SUSPENSION





# EBE E ADONE

CEILING

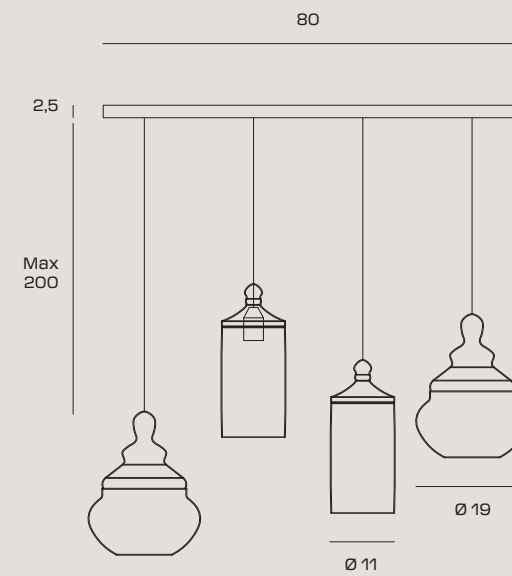

Lampada a sospensione composta da un rosone rettangolare Bianco di cm.80 e da 4 vetri: Miele, Fumè grigio e Trasparenti. Lampadine attacco E27 Led.

Suspension lamp with rectangular white ceiling canopy cm.80 composed of 4 glasses: amber, fumé and transparent. E27 Led bulbs.

Pendelleuchte in weißer, rechteckiger Fassung mit 80 cm Durchmesser, bestehend aus 4 Gläsern: Bernstein, Rauch und Transparent. E27 Led-Glühbirnen.

Lampe avec rosace rectangulaire blanche de 80 cm composée de 4 verres : ambre, fumée et transparents. Ampoules Led E27.

CODE 1744.40.KIT

GLASS Multicolor

#### LIGHT SOURCE

Source E27 LED | Power 4 x max 20w  
Max bulb size: Ø102xH150mm



# EBE E ADONE

**PERSONALIZZAZIONE EBE E ADONE SOSPENSIONE**  
**CUSTOMIZATION FOR EBE AND ADONE SUSPENSION LIGHT**  
**PERSONALISIERUNG EBE UND ADONE PENDELLEUCHTE**  
**PERSONNALISATION EBE ET ADONE SUSPENSION**

Possibilità creare una configurazione personalizzata a **3 o 4 luci** con le sospensioni Ebe e Adone in vetri di forme e colori diversi: fumè grigio, miele e trasparente. Cavo nero. Lunghezza max 200 cm.

Possibility to create a customised configuration with **3 or 4 lights** with Ebe and Adone pendant lamps in glass of different shapes and colours: smoky grey, honey and transparent. Black cable. Max. length: 200 cm.

Es besteht die Möglichkeit, eine individuelle **3- oder 4-Licht**-Konfiguration mit den Hängeleuchten Ebe und Adone aus Glas in verschiedenen Formen und Farben zu schaffen: rauchgrau, honigfarben und transparent. Schwarzes Kabel. Max. Länge 200 cm.

Possibilité de créer une configuration personnalisée de **3 ou 4 points lumineux** avec les suspensions Ebe et Adone et des verres de différentes formes et couleurs : gris fumé, miel et transparent. Câble noir. Longueur max. 200 cm.

## EBE

SOSPENSIONI/SUSPENSION/PENDELLEUCHTE/SUSPENSION



CODE	1744.12	1744.13
GLASS	○ Transparent	● Smoke Grey

## ADONE

SOSPENSIONI/SUSPENSION/PENDELLEUCHTE/SUSPENSION

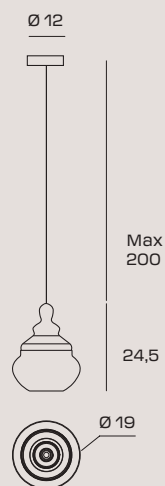

CODE	1744.14	1744.15
GLASS	○ Transparent	● Honey

**ROSONI PER COMPOSIZIONI LAMPADE A SOSPENSIONE**  
**CEILING CANOPY FOR PENDANT LAMP COMPOSITIONS**  
**ROSETTEN FÜR HÄNGELEUCHTENKOMPOSITIONEN**  
**ROSACES POUR COMPOSITIONS DE SUSPENSIONS**

Rosone per sospensioni verniciato bianco a **3, 4, 5 luci**. Cavi non inclusi.  
 White painted ceiling canopy for pendant lamps with **3, 4, 5 lights**. Cables not included.  
 Weiß lackierte Hängerose mit **3, 4, 5 Lichtern**. Kabel nicht enthalten.  
 Rosace pour suspension peinte en blanc à **3, 4, 5 points lumineux**. Câbles non inclus.

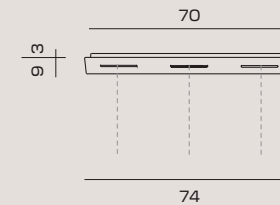

CODE 1730.M.37

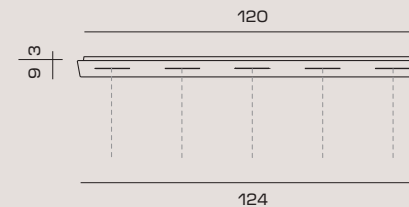

CODE 1730.M.38

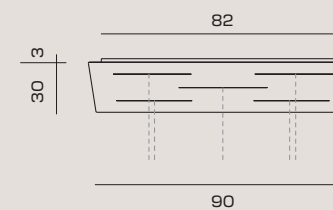

CODE 1730.M.39

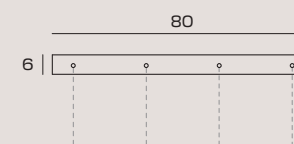

CODE 1744.M.40

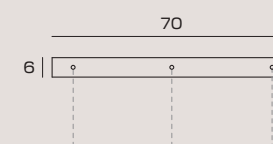

CODE 1744.M.41



# AMANITA

## AMANITA

Una celebrazione della natura sotto ogni aspetto. Amanita, grazie all'asimmetria tra stelo e diffusore che espande la potenza luminosa del punto luce e al color autunno dell'elemento a cappello, ricrea esattamente la sensazione di calore e intimità di una passeggiata nel bosco al calar del sole. Un connubio di elementi che rendono Amanita capace di catturare lo sguardo in ogni ambiente.

A celebration of nature in its every aspect. Thanks to the asymmetry between the stem and the diffuser, expanding the luminous power of the spot light, and to the autumn coloured hat element, Amanita perfectly recreates the feeling of warmth and intimacy of a walk in the woods at sunset. A combination of elements that make Amanita the centre of attention, in any environment.

Eine feier der natur in jeder hinsicht. dank der asymmetrie zwischen pendelrohr und diffusor, der die leuchtkraft der lichtquelle verbreitet, und der herbstlichen farbe des kappenelements erzeugt Amanita exakt das gefühl von wärme und intimität eines spaziergangs im wald bei untergehender sonne. Eine verschmelzung aus elementen, die dafür sorgt, dass Amanita in der lage ist, den blick in jedem ambiente auf sich zu ziehen.

Une célébration de la nature sous tous ses aspects. Grâce à l'asymétrie entre la tige et le diffuseur qui étend la puissance lumineuse du point lumineux et à la couleur automne de l'élément chapeau, Amanita recrée exactement la sensation de chaleur et d'intimité d'une promenade dans les bois au coucher du soleil. Une combinaison d'éléments grâce auxquels Amanita est capable de capturer le regard dans tout espace.



# AMANITA

TABLE





# AMANITA

TABLE

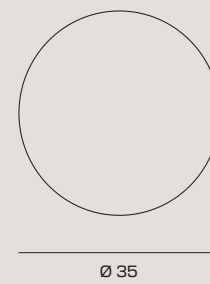
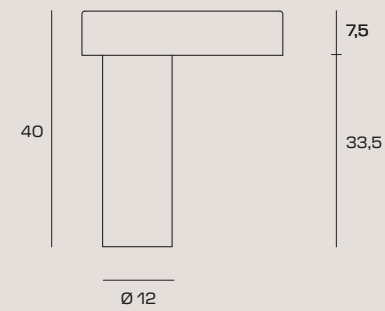

Lampada da tavolo in metallo.  
Base cilindrica con finitura in oro spazzolato.  
Paralume superiore in metallo color ruggine.  
Diffusore in metacrilato opalino.  
Cavo di alimentazione nero 150 cm.  
Lampadine installabili  
3 x G9 a LED dimmerabili.

Metal table lamp.  
Brushed gold cylinder base.  
Rusted metal top lampshade.  
Opal methacrylate diffuser.  
Black 150 cm power supply cord.  
Compatible with 3 x dimmable  
G9 LED light bulbs.

Tischleuchte aus Metall.  
Zylindrischer Sockel mit Finish in  
goldfarbener gebürsteter Ausführung.  
Oberer Lampenschirm aus  
rostfarbenem Metall.  
Diffusor aus Opal-Methacrylat.  
Stromkabel schwarz, 150 cm.  
Einbaubare Leuchtmittel 3 x G9  
mit LED, dimmbar.

Lampe de table en métal.  
Base cylindrique avec finition en or brossé.  
Abat-jour supérieur en métal couleur rouille.  
Diffuseur en méthacrylate opalin.  
Câble d'alimentation noir 150 cm.  
Possibilité d'installer 3 ampoule  
LED G9 dimmable.

CODE 1744.321

COLOR ● Brown

## LIGHT SOURCE

Source G9 LED DIMMABLE | Power 3 x max 10w  
Max bulb size: Ø20xH80mm

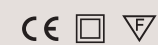



# SETTI

## SETTI

Un'unica lampada, molteplici apparenze. Setti, grazie al gioco di percezione creato dalla sovrapposizione delle linee che formano la gabbia dorata a cornice del punto luce, cambia sempre a seconda del modo in cui viene orientata. Con le sue dimensioni generose dona un forte contributo architettonico sia nell'applicazione da tavolo che a terra.

One lamp, multiple looks with its play of visual perception, created by the overlapping lines forming the golden cage around the lighting point, it always changes, depending on how it is directed. With its generous size, it is a strong architectural contribution both to a table and on the floor.

Eine einzige leuchte, vielfältige Erscheinungsformen. Setti ändert sich dank dem Spiel mit der Wahrnehmung durch die Überlagerung der Linien, die den goldenen Käfig als Rahmen für die Lichtquelle bilden, stets nach der Art und Weise, wie sie ausgerichtet wird. Mit ihren großzügigen Abmessungen liefert sie einen wichtigen architektonischen Beitrag, sowohl als Tischleuchte als auch als Stehleuchte.

Une seule lampe, de multiples apparences. Grâce au jeu de perception créé par la superposition des lignes qui forment la cage dorée en guise de cadre du point lumineux, Setti change en permanence en fonction de la manière dont elle est orientée. Avec ses dimensions généreuses, elle apporte une forte contribution architecturale, qu'il s'agisse de la lampe de table ou du lampadaire.





# SETTI

## TABLE

Lampada da tavolo in tondino con finitura in oro spazzolato. Diffusore interno in vetro opalino. Cavo di alimentazione nero 150 cm. Lampadina installabile E27 a LED dimmerabile.

Round bar table lamp with brushed gold finish. Internal opal glass diffuser. Black 150 cm power supply cord. Compatible with dimmable E27 LED light bulbs.

Tischleuchte aus Rundstahl mit goldfarbener, gebürsteter Ausführung. Innerer Diffusor aus Opalglas. Stromkabel schwarz, 150 cm. Einbaubares Leuchtmittel E27 mit LED, dimmbar.

Lampe de table en tube rond avec finition en or brossé. Diffuseur interne en verre opalin. Câble d'alimentation noir 150 cm. Possibilité d'installer 1 ampoule LED E27 dimmable.

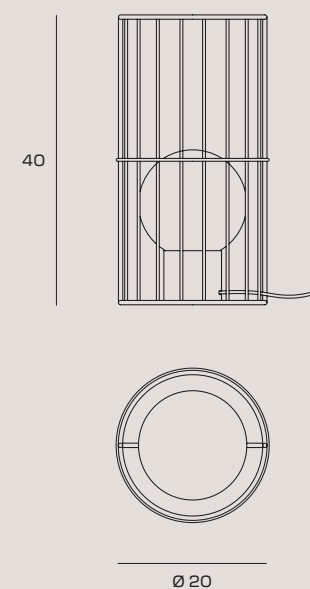

CODE	1744.322
COLOR	● Gold

### LIGHT SOURCE

Source E27 LED DIMMABLE | Power 1 x max 20w  
Max bulb size: Ø37xH120mm





# MUG

## MUG

Un luogo sicuro che ospita la luce.  
Mug raccoglie in un contenitore bianco crema in metallo dalle linee morbide e raggiate il punto luce; questo elemento centrale, dalla forte identità, è sorretto da un leggero stelo grafite che alleggerisce la composizione. Mug, grazie ai colori neutri e all'armonia delle forme, si inserisce con eleganza in ogni contesto.

A safe place to house light.  
Mug cuddles the spot light in a cream white metal container with soft radial lines. This central element with a strong identity is supported by a light graphite rod, to lighten up the composition. With its neutral colours and harmonic shapes, Mug fits elegantly in any context.

Ein sicherer ort, der das licht beherbergt.  
Mug birgt die lichtquelle in einem cremeweissen behälter aus metall mit weichen und abgerundeten linien; dieses zentrale element, mit starker identität, wird von einem leichten graphitfarbenen pendelrohr gestützt, das die komposition leichter macht. Dank der neutralen farben und der harmonie der formen fügt sich Mug mit eleganz in jeden kontext ein.

Un lieu sûr qui renferme la lumière.  
Mug renferme son point lumineux dans une structure en métal crème d'où rayonnent des lignes fluides ; cet élément central à la forte identité est soutenu par une fine tige en graphite qui allège la composition. Grâce à ses couleurs neutres et à ses formes harmonieuses, Mug s'insère avec élégance dans tous les contextes.

# MUG

SUSPENSION





# MUG

SUSPENSION





# MUG

CEILING LAMP





# MUG

CEILING LAMP



# MUG

## SUSPENSION

Lampada a sospensione con paralume in metallo color bianco crema e stelo in cromo spazzolato. Rosone in metallo finitura cromo spazzolato. Diffusore in materiale plastico opalino. Cavo di alimentazione nero 200 cm.

Suspension lamp with cream white metal lampshade and brushed chrome rod. Brushed chrome metal ceiling canopy. Opal plastic diffuser. Black 200 cm power supply cord.

Pendelleuchte mit Lampenschirm aus cremeweissem Metall und Pendelrohr aus gebürstetem Chrom. Baldachin aus Metall mit Finish aus gebürstetem Chrom. Diffusor aus Opal-Kunststoffmaterial. Stromkabel schwarz, 200 cm.

Suspension avec abat-jour en métal crème et tige chrome brossé. Rosace en métal, finition chrome brossé. Diffuseur en plastique opaline. Câble d'alimentation noir 200 cm.

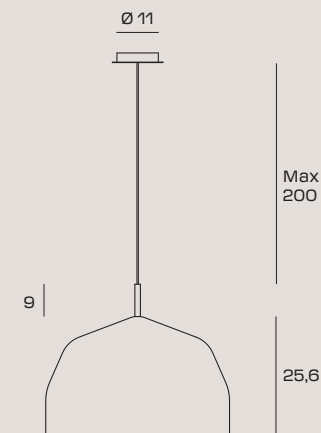
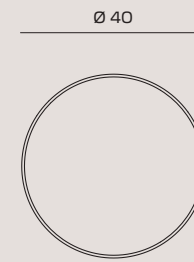
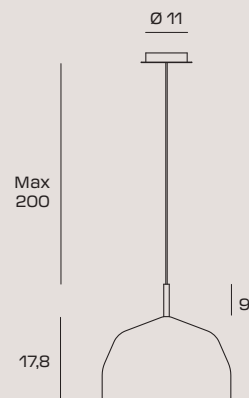
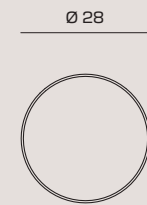

CODE 1744.326

COLOR  Cream

### LIGHT SOURCE

 Source E27 LED | Power 1 x max 20w  
Max bulb size: Ø50xH100mm



# MUG

## SUSPENSION

Lampada a sospensione con paralume in metallo color bianco crema e stelo in cromo spazzolato. Rosone in metallo finitura cromo spazzolato. Diffusore in materiale plastico opalino. Cavo di alimentazione nero 200 cm.

Suspension lamp with cream white metal lampshade and brushed chrome rod. Brushed chrome metal ceiling canopy. Opal plastic diffuser. Black 200 cm power supply cord.

Pendelleuchte mit Lampenschirm aus cremeweissem Metall und Pendelrohr aus gebürstetem Chrom. Baldachin aus Metall mit Finish aus gebürstetem Chrom. Diffusor aus Opal-Kunststoffmaterial. Stromkabel schwarz, 200 cm.

Suspension avec abat-jour en métal crème et tige chrome brossé. Rosace en métal, finition chrome brossé. Diffuseur en plastique opaline. Câble d'alimentation noir 200 cm.

CODE 1744.327

COLOR  Cream

### LIGHT SOURCE

 Source E27 LED | Power 3 x max 20w  
Max bulb size: Ø50xH100mm



# MUG

## SUSPENSION

Lampada a sospensione con paralume in metallo color bianco crema e stelo in cromo spazzolato. Rosone in metallo finitura cromo spazzolato. Diffusore in materiale plastico opalino. Cavo di alimentazione nero 200 cm.

Suspension lamp with cream white metal lampshade and brushed chrome rod. Brushed chrome metal ceiling canopy. Opal plastic diffuser. Black 200 cm power supply cord.

Pendelleuchte mit Lampenschirm aus cremeweissem Metall und Pendelrohr aus gebürstetem Chrom. Baldachin aus Metall mit Finish aus gebürstetem Chrom. Diffusor aus Opal-Kunststoffmaterial. Stromkabel schwarz, 200 cm.

Suspension avec abat-jour en métal crème et tige chrome brossé. Rosace en métal, finition chrome brossé. Diffuseur en plastique opaline. Câble d'alimentation noir 200 cm.

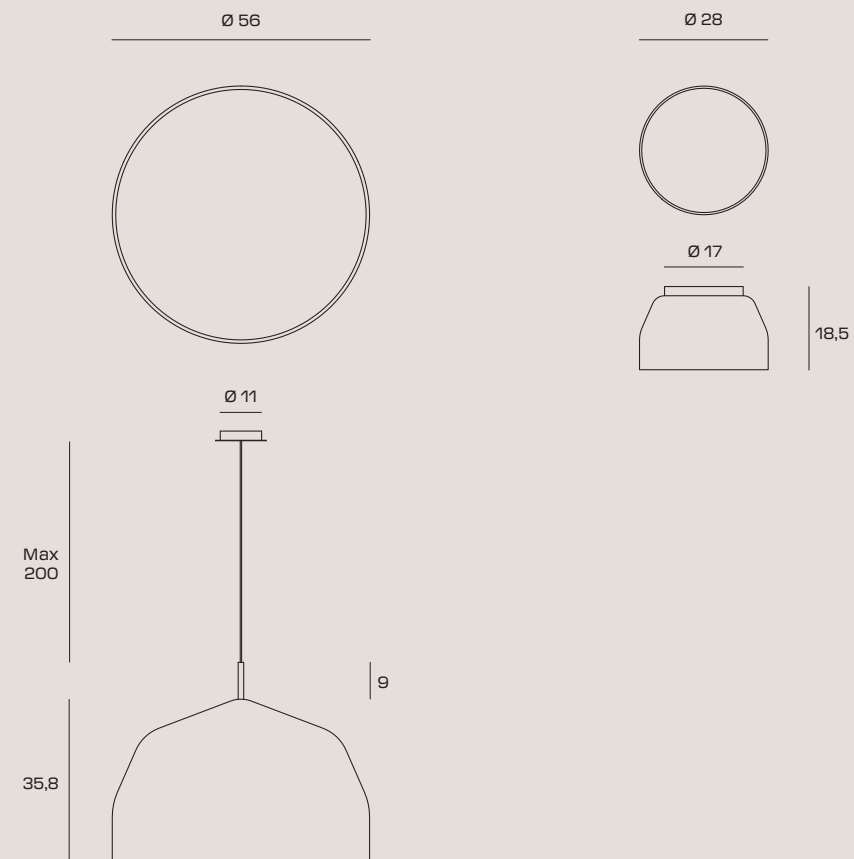

CODE 1744.328

COLOR  Cream

### LIGHT SOURCE

 Source E27 LED | Power 3 x max 20w  
Max bulb size:  $\varnothing 50 \times H100$ mm



# MUG

## CEILING LAMP

Lampada a soffitto con paralume in metallo color bianco crema. Rosone in metallo finitura cromo spazzolato. Diffusore in materiale plastico opalino.

Ceiling lamp with cream white metal lampshade. Brushed chrome metal ceiling canopy. Opal plastic diffuser.

Deckenleuchte mit Lampenschirm aus cremeweissem Metall. Baldachin aus Metall mit Finish aus gebürstetem Chrom. Diffusor aus Opal-Kunststoffmaterial.

Plafonnier avec abat-jour en métal crème. Rosace en métal, finition chrome brossé. Diffuseur en plastique opaline.

CODE 1744.323

COLOR  Cream

### LIGHT SOURCE

 Source E27 LED | Power 1 x max 20w  
Max bulb size:  $\varnothing 50 \times H100$ mm



# MUG

## CEILING LAMP

Lampada a soffitto con paralume in metallo color bianco crema. Rosone in metallo finitura cromo spazzolato. Diffusore in materiale plastico opalino.

Ceiling lamp with cream white metal lampshade. Brushed chrome metal ceiling canopy. Opal plastic diffuser.

Deckenleuchte mit Lampenschirm aus cremeweissem Metall. Baldachin aus Metall mit Finish aus gebürstetem Chrom. Diffusor aus Opal-Kunststoffmaterial.

Plafonnier avec abat-jour en métal crème. Rosace en métal, finition chrome brossé. Diffuseur en plastique opaline.

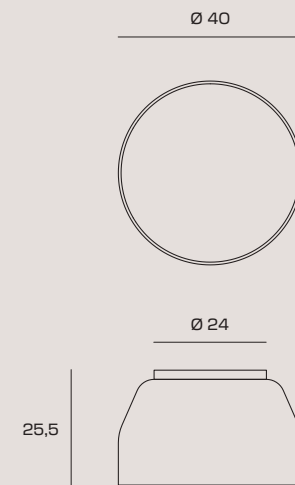

CODE 1744.324

COLOR  Cream

### LIGHT SOURCE

 Source E27 LED | Power 3 x max 20w  
Max bulb size: Ø50xH100mm



# MUG

## CEILING LAMP

Lampada a soffitto con paralume in metallo color bianco crema. Rosone in metallo finitura cromo spazzolato. Diffusore in materiale plastico opalino.

Ceiling lamp with cream white metal lampshade. Brushed chrome metal ceiling canopy. Opal plastic diffuser.

Deckenleuchte mit Lampenschirm aus cremeweissem Metall. Baldachin aus Metall mit Finish aus gebürstetem Chrom. Diffusor aus Opal-Kunststoffmaterial.

Plafonnier avec abat-jour en métal crème. Rosace en métal, finition chrome brossé. Diffuseur en plastique opaline.

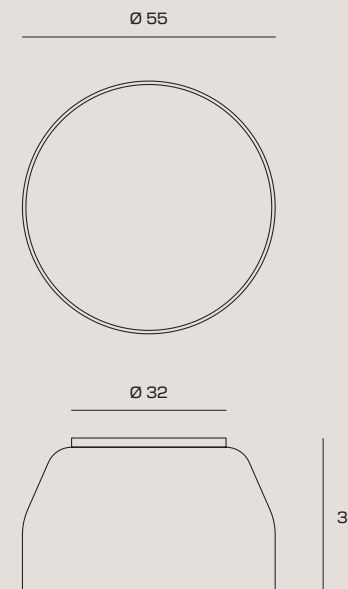

CODE 1744.325

COLOR  Cream

### LIGHT SOURCE

 Source E27 LED | Power 3 x max 20w  
Max bulb size: Ø50xH100mm





# KLOÉ

## KLOÉ

Sovrapposizione di luce,  
incastro perfetto di elementi.  
Kloe si caratterizza per la presenza  
di tre componenti di grande impatto visivo  
che dialogano tra loro, creando un insieme  
dall'estetica ricca capace di connotare  
ogni ambiente in cui viene inserita.  
L'eleganza senza tempo di Kloe, data dalla  
struttura e dal colore tenue della finitura,  
fa sì che possa essere posizionata in qualsiasi  
contesto, dal classico al moderno.

Superimposition of light,  
the perfect blend of elements.  
Kloe is characterised by the presence  
of three visually striking components  
dialoguing with each other to create a whole  
rich aesthetics capable of connoting  
every environment in which it is inserted.  
Kloe's timeless elegance, given by the  
structure and the soft colour of the finish,  
means that it can be placed in any context,  
be it classic or modern.

Überlagerung von Licht, perfekte  
Verzahnung der Elemente.  
Kloe zeichnet sich durch das Vorhandensein  
von drei visuell auffälligen Komponenten aus,  
die miteinander in Dialog treten und ein  
Ensemble mit reicher Ästhetik schaffen,  
das in der Lage ist, jede Umgebung, in die  
sie eingefügt wird, zu prägen.  
Die zeitlose Eleganz von Kloe, die durch die  
Struktur und die sanfte Farbe der Oberfläche  
gegeben ist, bedeutet, dass sie sich in jeden  
Kontext einfügen lässt, von klassisch bis modern.

Superposition de lumière,  
mélange parfait d'éléments.  
Kloe se caractérise par la présence de trois  
éléments d'une grande force visuelle  
qui dialoguent entre eux et créent ainsi  
un ensemble dont l'esthétique est en mesure  
de connoter tous les types d'espace.  
L'élégance intemporelle de Kloe, liée à sa  
structure et à la couleur délicate de sa finition,  
permet de la placer dans n'importe quel  
contexte, classique au moderne.



KLOÉ  
SUSPENSION





# KLOÉ

## SUSPENSION

Lampada a sospensione  
in metallo verniciato tortora  
e montatura ottone spazzolato.  
Cavo di alimentazione nero 200 cm.  
Rosone tortora.

Suspension lamp  
made of dove grey painted metal  
and brushed brass support.  
Black 200 cm power supply cord.  
Dove grey ceiling canopy.

Hängeleuchte aus taubengrau  
lackiertem Metall und  
gebürstetem Messinggestell.  
Schwarzes Stromkabel 200 cm.  
Taubengraue Rosette.

Suspension  
en métal peint tourterelle  
et monture en laiton brossé.  
Câble d'alimentation noir 200 cm.  
Rosace gris colombe.

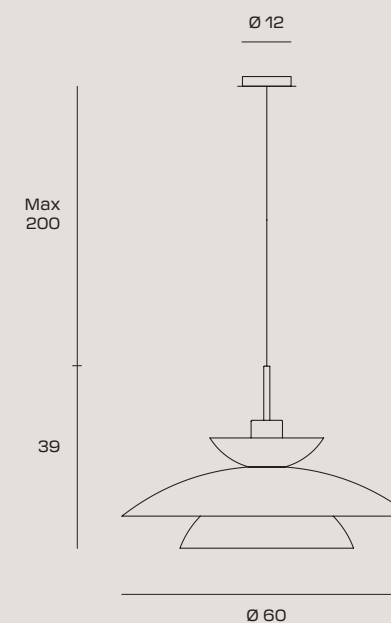

CODE 1744.293

COLOR ● Dove Grey

### LIGHT SOURCE

Source E27 LED | Power 1 x max 20w  
Max bulb size: Ø55xH200mm





# KIM

## KIM

Una farfalla appena sbocciata,  
preziosa ed evanescente.  
Il corpo di Kim, in metallo verniciato azzurro,  
sottolinea il linguaggio deciso delle forme  
e la forte personalità di questa realizzazione:  
una lampada in cui convivono armoniosamente  
senso di leggerezza e percezione di raffinatezza,  
conferita dai particolari in oro spazzolato.  
La presenza di Kim arricchisce ogni spazio,  
conferendogli un carattere di unicità.

A newly blooming butterfly,  
precious and evanescent.  
Kim's body is made of light blue painted metal,  
which emphasises the strong language of  
forms and the strong personality of this piece:  
a lamp in which a sense of lightness and  
a perception of refinement, conferred by  
brushed gold details, coexist harmoniously.  
Kim's presence enriches every space,  
making it unique.

Ein frisch geschlüpfter Schmetterling,  
kostbar und flüchtig.  
Der blau lackierte Metallkorpus von Kim  
unterstreicht die entschiedene Formensprache  
und die starke Persönlichkeit dieser Kreation:  
eine Leuchte, bei der das Gefühl von Leichtigkeit  
und die Wahrnehmung von Raffinesse, die durch  
die Details aus gebürstetem Gold vermittelt wird,  
harmonisch nebeneinander bestehen.  
Kims Präsenz bereichert jeden Raum und  
verleiht ihm einen einzigartigen Charakter.

Un papillon qui vient de naître,  
précieux et évanescent.  
La structure de Kim est en métal peint bleu clair  
et souligne le langage puissant des formes  
et la personnalité de cette réalisation :  
une lampe qui associe avec harmonie légèreté  
et raffinement grâce aux détails en or brossé.  
La présence de Kim raffine chaque espace,  
et lui confère un caractère unique.

KIM  
SUSPENSION





# KIM

## SUSPENSION

Lampada a sospensione  
in metallo verniciato azzurro cielo  
e montatura in ottone spazzolato.  
Cavo di alimentazione nero 200 cm.  
Rosone azzurro cielo.

Suspension lamp  
made of sky blue painted metal  
and brushed brass support.  
Black 200 cm power supply cord.  
Sky blue ceiling canopy.

Hängeleuchte aus himmelblau  
lackiertem Metall und gebürstetem  
Messinggestell.  
Schwarzes Stromkabel 200 cm.  
Himmelblaue Rosette.

Suspension  
en métal peint bleu clair  
à monture en laiton brossé.  
Câble d'alimentation noir 200 cm.  
Rosace bleu ciel.

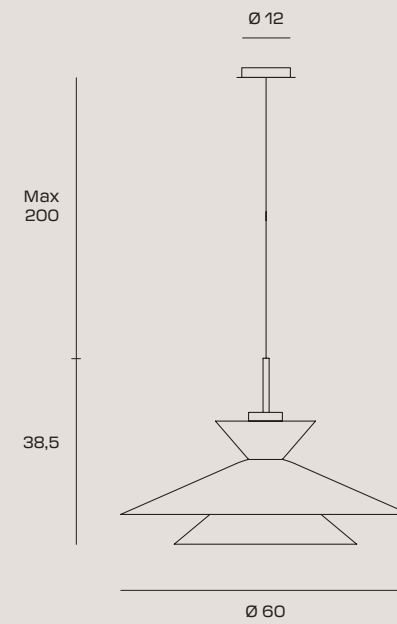

CODE	1744.294
COLOR	<span style="color: #4682B4;">●</span> Sky Blue

### LIGHT SOURCE

 Source E27 LED | Power 1 x max 20w  
Max bulb size: Ø55xH200mm





# SAMOI

## SAMOI

Forma unica, molteplici espressioni. In Samoi l'idea originale - l'elemento minimale del cono - assume diverse manifestazioni presentandosi in proporzioni e dimensioni differenti capaci di vivere singolarmente o di creare scenari unici in composizioni multiple. La semplicità del disegno iniziale fa di Samoi un oggetto discreto e funzionale a cui la finitura in metallo nero soft touch dona un tocco di contemporaneità.

Single form, multiple expressions. In Samoi, the original idea - the minimal cone element - takes on different manifestations by presenting themselves in varied proportions and dimensions, capable of existing individually or to create unique scenarios in multiple compositions. The simplicity of the initial design makes Samoi a discreet and functional object to which the black soft-touch metal finish gives a contemporary touch.

Einmalige Form, mehrere Ausdrücke. In Samoi nimmt die ursprüngliche Idee - das minimale Element des Kegels - verschiedene Erscheinungsformen an und präsentiert sich in unterschiedlichen Proportionen und Größen, die in der Lage sind, einzeln zu leben oder einzigartige Szenarien in mehreren Kompositionen zu schaffen. Die Schlichtheit des ursprünglichen Designs macht Samoi zu einem diskreten und funktionalen Objekt, dem die schwarze Soft-Touch-Metalloberfläche einen modernen Touch verleiht.

Une seule forme, une multitude d'expressions. Dans Samoi, l'idée originale - l'élément cône minimaliste - revêt différentes formes et présente des proportions et des dimensions diversifiées capable d'autonomie et de créer des scénarios uniques avec de multiples compositions. La simplicité de sa conception initiale fait de Samoi un objet discret et fonctionnel, auquel la finition en métal noire soft touch confère une touche contemporaine.

# SAMOI

SUSPENSION



# SAMOI

SUSPENSION





# SAMOI

SUSPENSION



# SAMOI

SUSPENSION





# SAMOI

SUSPENSION

Lampada a sospensione in metallo verniciato a polvere: colore esterno nero soft touch, interno bianco, diametro 60 cm. Stelo in ottone spazzolato e cavi di alimentazione altezza 200 cm.

Pendant light in powder coated metal: soft touch black finish on the outside, white on the inside, measuring 60 cm in diameter. Brushed brass stem and 200 cm. cables.

Pendelleuchte aus pulverbeschichtetem Metall. Außen Soft-Touch-Schwarz, innen Weiß, Durchmesser 60 cm. Pendelrohr aus gebürstetem Messing und Stromkabel 200 cm.

Suspension en métal revêtu de peinture poudre : extérieur noir soft touch, intérieur blanc, diamètre 60 cm. Tige en laiton brossé et câbles d'alimentation hauteur 200 cm.

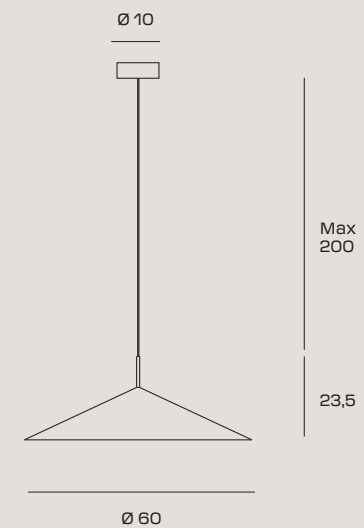

CODE	1744.108
COLOR	● Black

#### LIGHT SOURCE

Source E27 LED | Power 1 x max 20w  
Max bulb size: Ø180xH200mm



# SAMOI

## SUSPENSION

Lampada a sospensione  
in metallo verniciato a polvere:  
colore esterno nero soft touch,  
interno bianco, diametro 26,5 cm.  
Stelo in ottone spazzolato e cavi di  
alimentazione altezza 200 cm.

Pendant light in powder coated  
metal: soft touch black finish on the  
outside, white on the inside,  
measuring 26.5 cm in diameter.  
Brushed brass stem and  
200 cm. cables.

Pendelleuchte aus  
pulverbeschichtetem Metall.  
Außen Soft-Touch-Schwarz,  
innen Weiß, Durchmesser 26,5 cm.  
Pendelrohr aus gebürstetem  
Messing und Stromkabel 200 cm.

Suspension métal revêtu  
de peinture poudre :  
extérieur noir soft touch,  
intérieur blanc, diamètre 26,5 cm.  
Tige en laiton brossé et câbles  
d'alimentation 200 cm.

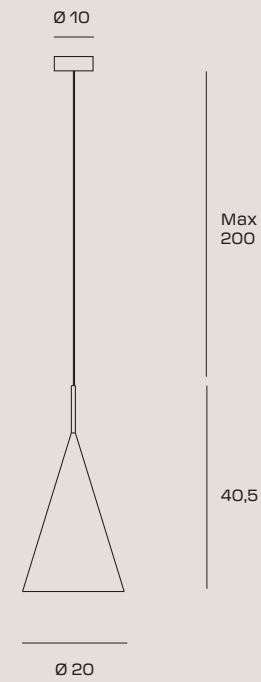
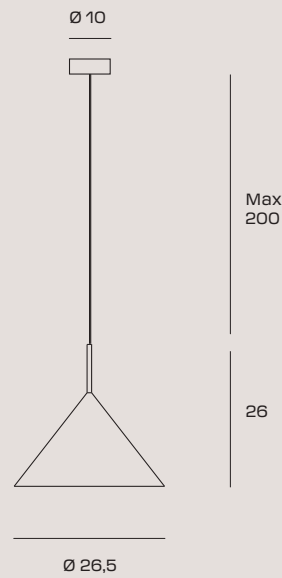

# SAMOI

## SUSPENSION

Lampada a sospensione  
in metallo verniciato a polvere:  
colore esterno nero soft touch,  
interno bianco, diametro 20 cm.  
Stelo in ottone spazzolato e cavi  
di alimentazione altezza 200 cm.

Pendant light in powder coated metal:  
soft touch black finish  
on the outside, white on the inside,  
measuring 20 cm in diameter.  
Brushed brass stem and  
200 cm. cables.

Pendelleuchte aus  
pulverbeschichtetem Metall.  
Außen Soft-Touch-Schwarz,  
innen Weiß, Durchmesser 20 cm.  
Pendelrohr aus gebürstetem  
Messing und Stromkabel 200 cm.

Suspension en métal  
revêtu de peinture poudre :  
extérieur noir soft touch,  
intérieur blanc, diamètre 20 cm  
Tige en laiton brossé et câbles  
d'alimentation hauteur 200 cm.

CODE	1744.109
COLOR	● Black

### LIGHT SOURCE

Source E27 LED | Power 1 x max 20w  
Max bulb size: Ø80xH140mm



CODE	1744.110
COLOR	● Black

### LIGHT SOURCE

Source E27 LED | Power 1 x max 20w  
Max bulb size: Ø80xH200mm



# SAMOI

## SUSPENSION

Lampada a sospensione a 3 luci in metallo verniciato a polvere: colore esterno nero soft touch, interno bianco. Stelo in ottone spazzolato. Dotata di Kit di decentramento e cavi di alimentazione altezza 200 cm. È possibile configurare una sospensione mixando le lampade della serie Samoi (1744.108; 1744.109; 1744.110) a fianco un esempio.

3-light suspension lamp made of powder-coated metal: soft-touch black on the outside, white on the inside. Brushed brass rod. With shifting kit and 200 cm long power supply cord. You can configure a suspension by mixing the Samoi series lamps (1744.108; 1744.109; 1744.110) as shown in the example to the side.

Hängeleuchte mit 3 Lichtern aus pulverbeschichtetem Metall: Außenfarbe schwarz soft touch, Innenfarbe weiß. Schaft aus gebürstetem Messing. Mit Dezentralisierungskit und Stromkabeln, Höhe 200 cm. Es kann eine Hängeleuchte konfiguriert werden, indem die Leuchten der Samoi-Serie (1744.108; 1744.109; 1744.110) gemischt werden. Hier ist ein Beispiel.

Suspension à 3 points lumineux en métal revêtu de peinture poudre : extérieur noir soft touch, intérieur blanc Tige en laiton brossé. Équipé d'un kit de décentralisation et câbles d'alimentation 200 cm. Vous pouvez configurer une suspension en associant les lampes de la série Samoi (1744.108; 1744.109; 1744.110) exemple sur le côté.

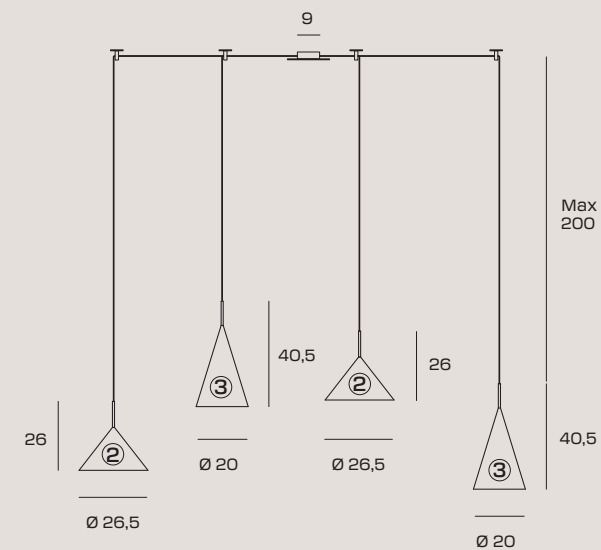
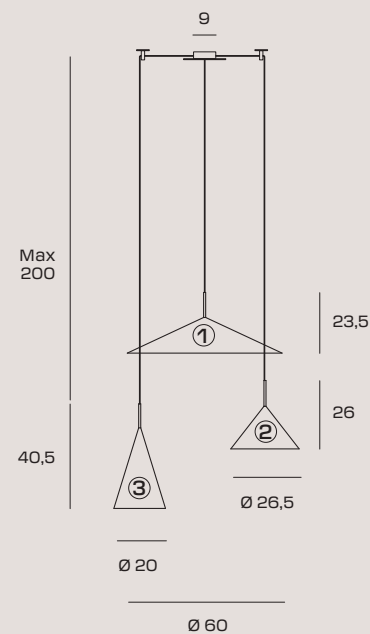

# SAMOI

## SUSPENSION

Lampada a sospensione a 4 luci in metallo verniciato a polvere: colore esterno nero soft touch, interno bianco. Stelo in ottone spazzolato. Dotata di Kit di decentramento e cavi di alimentazione altezza 120 cm. È possibile configurare una sospensione mixando le lampade della serie Samoi (1744.108; 1744.109; 1744.110) a fianco un esempio.

4-light suspension lamp made of powder-coated metal: soft-touch black on the outside, white on the inside. Brushed brass rod. With shifting kit and 120 cm long power supply cord. You can configure a suspension by mixing the Samoi series lamp (1744.108; 1744.109; 1744.110) as shown in the example to the side.

Hängeleuchte mit 4 Lichtern aus pulverbeschichtetem Metall: Außenfarbe schwarz soft touch, Innenfarbe weiß. Schaft aus gebürstetem Messing. Mit Dezentralisierungskit und Stromkabeln, Höhe 120 cm. Es kann eine Hängeleuchte konfiguriert werden, indem die Leuchten der Samoi-Serie (1744.108; 1744.109; 1744.110) gemischt werden. Hier ist ein Beispiel.

Suspension à 4 points lumineux en métal revêtu de peinture poudre : extérieur noir soft touch, intérieur blanc. Tige en laiton brossé. Équipé d'un kit de décentralisation et d'un câbles d'alimentation 120 cm. Vous pouvez configurer une suspension en associant les lampes de la série Samoi (1744.108; 1744.109; 1744.110) exemple sur le côté.

CODE	1744.116.KIT
COLOR	● Black

### LIGHT SOURCE

Source E27 LED | Power 3 x max 20w  
Max bulb size: ①: Ø180xH200mm  
②: Ø80xH140mm  
③: Ø80xH200mm



CODE	1744.299.KIT
COLOR	● Black

### LIGHT SOURCE

Source E27 LED | Power 4 x max 20w  
Max bulb size: ②: Ø80xH140mm  
③: Ø80xH200mm

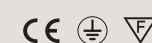

# SAMOI

## SUSPENSION

Lampada a sospensione a 5 luci in metallo verniciato a polvere: colore esterno nero soft touch, interno bianco. Stelo in ottone spazzolato. Dotata di Kit di decentramento e cavi di alimentazione altezza 200 cm. È possibile configurare una sospensione mixando le lampade della serie Samoi (1744.108; 1744.109; 1744.110) a fianco un esempio.

5-light suspension lamp made of powder-coated metal: soft-touch black on the outside, white on the inside. Brushed brass rod. With shifting kit and 200 cm long power supply cord. You can configure a suspension by mixing the Samoi series lamps (1744.108; 1744.109; 1744.110) as shown in the example to the side.

Hängeleuchte mit 5 Lichtern aus pulverbeschichtetem Metall: Außenfarbe schwarz soft touch, Innenfarbe weiß. Schaft aus gebürstetem Messing. Mit Dezentralisierungskit und Stromkabeln, Höhe 200 cm. Es kann eine Hängeleuchte konfiguriert werden, indem die Leuchten der Samoi-Serie (1744.108; 1744.109; 1744.110) gemischt werden. Hier ist ein Beispiel.

Suspension à 5 points lumineux en métal revêtu de peinture poudre : extérieur noir soft touch, intérieur blanc Tige en laiton brossé. Équipé d'un kit de décentralisation et câbles d'alimentation 200 cm. Vous pouvez configurer une suspension en associant les lampes de la série Samoi (1744.108; 1744.109; 1744.110) exemple sur le côté.

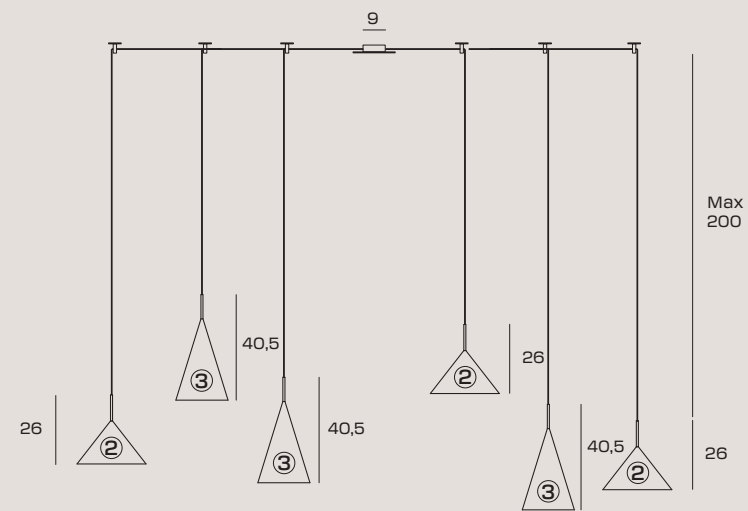
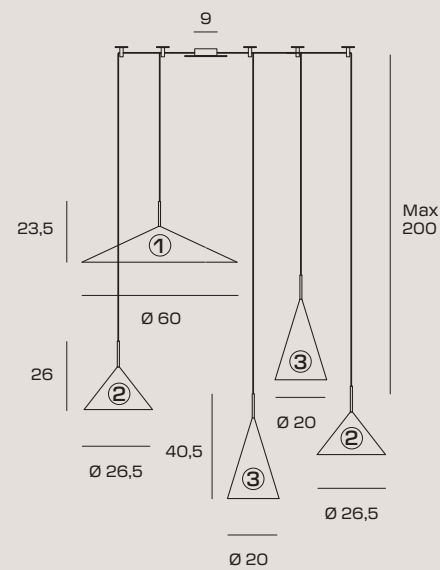

# SAMOI

## SUSPENSION

Lampada a sospensione a 6 luci in metallo verniciato a polvere: colore esterno nero soft touch, interno bianco. Stelo in ottone spazzolato. Dotata di Kit di decentramento e cavi di alimentazione altezza 200 cm. È possibile configurare una sospensione mixando le lampade della serie Samoi (1744.108; 1744.109; 1744.110) a fianco un esempio.

6-light suspension lamp made of powder-coated metal: soft-touch black on the outside, white on the inside. Brushed brass rod. With shifting kit and 200 cm long power supply cord. You can configure a suspension by mixing the Samoi series lamps (1744.108; 1744.109; 1744.110) as shown in the example to the side.

Hängeleuchte mit 6 Lichtern aus pulverbeschichtetem Metall: Außenfarbe schwarz soft touch, Innenfarbe weiß. Schaft aus gebürstetem Messing. Mit Dezentralisierungskit und Stromkabeln, Höhe 200 cm. Es kann eine Hängeleuchte konfiguriert werden, indem die Leuchten der Samoi-Serie (1744.108; 1744.109; 1744.110) gemischt werden. Hier ist ein Beispiel.

Suspension à 6 points lumineux en métal revêtu de peinture poudre : extérieur noir soft touch, intérieur blanc Tige en laiton brossé. Équipé d'un kit de décentralisation et de câbles d'alimentation hauteur 200 cm. Vous pouvez configurer une suspension en associant les lampes de la série Samoi (1744.108; 1744.109; 1744.110) exemple sur le côté.

CODE	1744.300.KIT
COLOR	● Black

### LIGHT SOURCE

Source E27 LED | Power 3 x max 20w  
Max bulb size: ①: Ø180xH200mm  
②: Ø80xH140mm  
③: Ø80xH200mm



CODE	1744.301.KIT
COLOR	● Black

### LIGHT SOURCE

Source E27 LED | Power 4 x max 20w  
Max bulb size: ②: Ø80xH140mm  
③: Ø80xH200mm



# SAMOI

## PERSONALIZZAZIONE SAMOI SOSPENSIONE CUSTOMIZATION FOR SAMOI SUSPENSION LIGHT PERSONALISIERUNG SAMOI PENDELLEUCHTE PERSONNALISATION SAMOI SUSPENSION

Possibilità di creare una configurazione personalizzata a **3, 4, 5 e 6 luci** con le sospensioni Samoi di forme diverse.  
Cavo trasparente. Lunghezza max 200 cm.

Possibility to create a customised configuration with **3, 4, 5 or 6 lights** with Samoi pendant lamps in different shapes.  
Transparent cable. Max. length: 200 cm.

Mit den unterschiedlich geformten Samoi-Hängeleuchten kann eine individuelle **3-, 4-, 5- und 6-Licht**-Konfiguration erstellt werden. Transparentes Kabel. Max. Länge 200 cm.

Possibilité de créer une configuration personnalisée de **3, 4, 5 ou 6 points lumineux** avec des suspensions Samoi de formes différentes. Câble transparent. Longueur max. 200 cm.

### FORMA/SHAPE/BILDEN/FORME



## ROSONI A SOFFITTO CEILING CANOPY DECKENLAMPEN ROSACES DE PLAFOND

Rosoni per composizioni a **3, 4, 5, 6 luci**. Rosone centrale ø 9 cm con passacavi a soffitto. Cavi non inclusi.  
Ceiling canopy for compositions with **3, 4, 5, 6 lights**. Central ceiling canopy ø 9 cm lamp with grommet. Cables not included.  
Rosetten für Kompositionen mit **3, 4, 5, 6 Lichtern**. Mittellosette ø 9 cm mit Kabeldurchführung für die Decke. Kabel nicht enthalten.  
Rosaces pour compositions à **3, 4, 5, 6 points lumineux**. Rosace centrale ø 9 cm avec guide-câble pour plafond. Câbles non inclus.

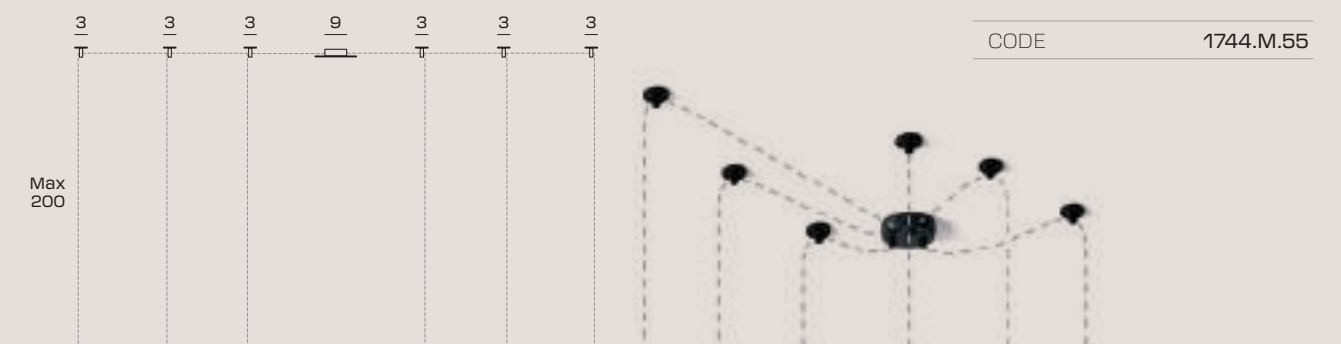



# GRAAL

## GRAAL

Simbolismo e misticismo racchiusi in un segno assimilato e popolare. Graal è una vera rivelazione: il paralume, un chiaro rimando all'archetipo di lampada, è rivisitato in un lessico contemporaneo e distintivo; così la lampada si fa collegamento tra storia, culto ed attualità. Un legame che trova la sua espressione nell'anello che regge il paralume, elemento connotante di Graal in tutte le declinazioni. La finitura in metallo verniciato grigio e i dettagli nero opaco si combinano per creare una palette cromatica sobria, adatta ad ogni contesto.

Symbolism and mysticism encapsulated in an assimilated and popular sign. Graal is a real revelation: the lampshade, a clear reference to the lamp archetype, is revisited in a contemporary and distinctive lexicon, and the lamp becomes the connection between history, cult and current events. A bond that finds its expression in the ring holding the lampshade, a signature element of Graal in all its declinations. The grey painted metal finish and matt black details are combined, to create an understated colour palette suitable for any context.

Symbolik und Mystik in einem assimilierten und populären Zeichen. Graal ist eine echte Offenbarung: Der Lampenschirm, ein klarer Verweis auf den Archetypus der Lampe, wird in einem zeitgenössischen und unverwechselbaren Lexikon neu interpretiert; so wird die Lampe zu einer Verbindung zwischen Geschichte, Kult und Aktualität. Eine Verbindung, die in dem Ring, der den Lampenschirm hält, ihren Ausdruck findet, ein konnotatives Element von Graal in all ihren Deklinationen. Die grau lackierte Metalloberfläche und die mattschwarzen Details bilden eine schlichte Farbpalette, die sich für jeden Kontext eignet.

Symbolisme et mysticisme renfermés dans un signe assimilé et populaire. Graal est une véritable révélation : l'abat-jour, référence claire à l'archétype de la lampe, est revisité dans un lexique contemporain et distinctif ; la lampe établit ainsi le lien entre l'histoire, la culture et l'actualité. Un lien qui s'exprime dans l'anneau supportant l'abat-jour, symbole du Graal dans toutes ses déclinaisons. La finition en métal peint gris et les détails noir mat composent une palette de couleurs sobres adaptée à tous les contextes.

# GRAAL

SUSPENSION



# GRAAL

SUSPENSION



# GRAAL

TABLE





# GRAAL

WALL LAMP





# GRAAL

FLOOR LAMP





# GRAAL

FLOOR LAMP

Lampada da terra a 2 luci  
con montatura in metallo  
verniciato grigio con particolari neri.  
Cavo di alimentazione  
dotato di dimmer.

2-light ground lamp  
with grey painted metal  
support with black details.  
Power supply cord  
with dimmer.

Bodenleuchte mit 2 Lichtern  
mit grau lackiertem Metallgestell  
mit schwarzen Details.  
Netzkabel mit Dimmer.

Lampadaire 2 points lumineux  
avec monture en métal  
peinte en gris avec détails noirs.  
Câble d'alimentation  
avec variateur.



CODE	1744.245
COLOR	● Grey

#### LIGHT SOURCE

Source | E27 LED DIMMABLE | Power | 2 x max 20w  
Max bulb size: Ø60xH100mm

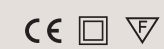

# GRAAL

## SUSPENSION

Lampada da soffitto a 5 luci  
con montatura in metallo  
verniciato grigio con particolari neri.  
Portalampada con attacco E27.

5-light ceiling lamp  
with grey painted metal  
support with black details.  
Lamp holder with E27 coupling.

Deckenleuchte mit 5 Lichtern  
mit grau lackiertem Metallgestell  
mit schwarzen Details.  
E27-Lampenfassung.

Plafonnier 5 points lumineux  
avec monture en métal  
peinte en gris avec détails noirs.  
Support de connexion E27.

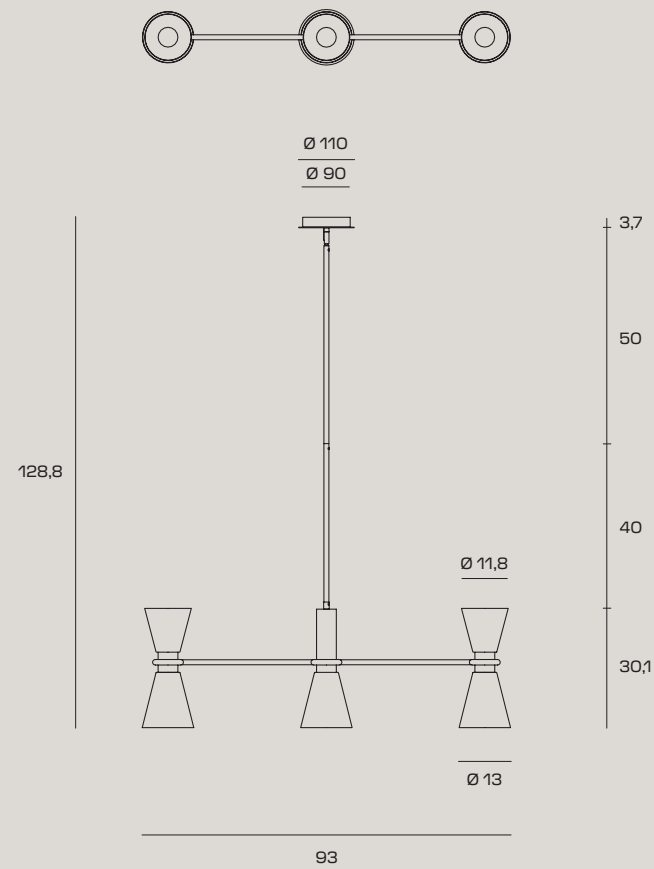

CODE 1744.241

COLOR ● Grey

### LIGHT SOURCE

Source E27 LED | Power 5 x max 20w  
Max bulb size: Ø60xH100mm



# GRAAL

## SUSPENSION

Lampada da soffitto a 13 luci  
con montatura in metallo  
verniciato grigio con particolari neri.  
Portalampada con attacco E27.

13-light ceiling lamp  
with grey painted metal  
support with black details.  
Lamp holder with E27 coupling.

Deckenleuchte mit 13 Lichtern  
mit grau lackiertem Metallgestell  
mit schwarzen Details.  
E27-Lampenfassung.

Plafonnier 13 points lumineux  
avec monture en métal  
peinte en gris avec détails noirs.  
Support de connexion E27.

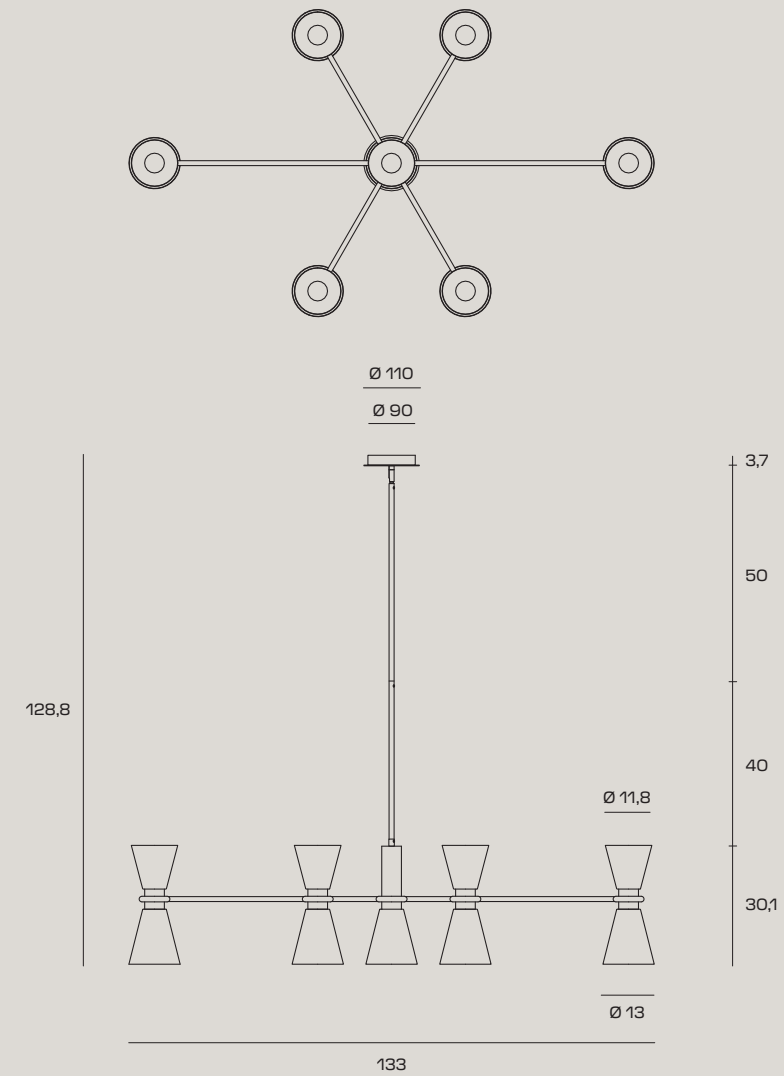

CODE 1744.242

COLOR ● Grey

### LIGHT SOURCE

Source E27 LED | Power 13 x max 20w  
Max bulb size: Ø60xH100mm



# GRAAL

## TABLE

Lampada da tavolo a 2 luci  
con montatura in metallo  
verniciato grigio con particolari neri.  
Cavo di alimentazione  
dotato di dimmer.

2-light table lamp  
with grey painted metal  
support with black details.  
Power supply cord  
with dimmer.

Tischleuchte mit 2 Lichtern  
mit grau lackiertem Metallgestell  
mit schwarzen Details.  
Netzkabel mit Dimmer.

Lampe de table 2 point lumineux  
avec monture en métal  
peinte en gris avec détails noirs.  
Câble d'alimentation  
avec variateur.

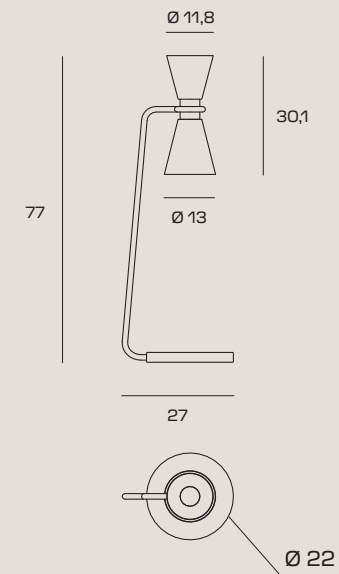
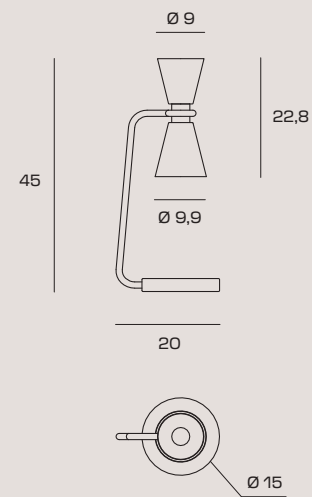

# GRAAL

## TABLE

Lampada da tavolo a 2 luci  
con montatura in metallo  
verniciato grigio con particolari neri.  
Cavo di alimentazione  
dotato di dimmer.

2-light table lamp  
with grey painted metal  
support with black details.  
Power supply cord  
with dimmer.

Tischleuchte mit 2 Lichtern  
mit grau lackiertem Metallgestell  
mit schwarzen Details.  
Netzkabel mit Dimmer.

Lampe de table 2 point lumineux  
avec monture en métal  
peinte en gris avec détails noirs.  
Câble d'alimentation  
avec variateur.

CODE 1744.243

COLOR  Grey

### LIGHT SOURCE

 Source G9 LED DIMMABLE | Power 2 x max 10w  
Max bulb size: Ø60xH100mm



CODE 1744.244

COLOR  Grey

### LIGHT SOURCE

 Source E27 LED DIMMABLE | Power 2 x max 20w  
Max bulb size: Ø60xH100mm



# GRAAL

## WALL LAMP

Lampada da parete a 2 luci  
con montatura in metallo  
verniciato grigio con particolari neri.  
Portalamпада con attacco G9.

2-light wall lamp  
with grey painted metal  
support with black details.  
Lamp holder with G9 coupling.

Wandleuchte mit 2 Lichtern  
mit grau lackiertem Metallgestell  
mit schwarzen Details.  
G9-Lampenfassung.

Applique 2 points lumineux  
avec monture en métal  
peinte en gris avec détails noirs.  
Support de connexion G9.

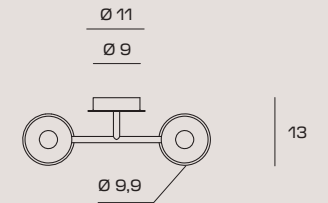
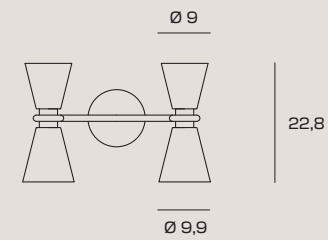
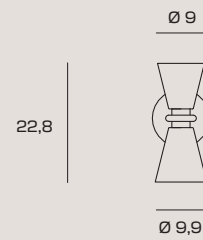

36,1

# GRAAL

## WALL LAMP

Lampada da parete a 4 luci  
con montatura in metallo  
verniciato grigio con particolari neri.  
Portalamпада con attacco G9.

4-light wall lamp  
with grey painted metal  
support with black details.  
Lamp holder with G9 coupling.

Wandleuchte mit 4 Lichtern  
mit grau lackiertem Metallgestell  
mit schwarzen Details.  
G9-Lampenfassung.

Applique 4 points lumineux  
avec monture en métal  
peinte en gris avec détails noirs.  
Support de connexion G9.

CODE	1744.239
COLOR	● Grey

### LIGHT SOURCE

Source G9 LED | Power 2 x max 28w  
Max bulb size: Ø20xH70mm



CODE	1744.240
COLOR	● Grey

### LIGHT SOURCE

Source G9LED | Power 4 x max 28w  
Max bulb size: Ø20xH70mm





# PYRA

## PYRA

Il classico paralume rivisitato in chiave moderna, giocando con la compenetrazione di corpi e materiali dalle caratteristiche opposte. In Pyra la severità e il rigore dell'architettura interna vengono addolciti dal tessuto sottile effetto lino, regalando una sensazione di equilibrio. Con le sue tonalità neutre, Pyra può abbinarsi facilmente a qualsiasi stile presente nell'ambiente.

A classic lampshade reinterpreted in a modern way, by playing with intermingling objects and materials with opposing characteristics. In Pyra, the strict and rigorous internal structure is mellowed by the soft, linen-effect fabric, for a balanced sensation. With its neutral tones, Pyra can be easily paired with any room style.

Der klassische lampenschirm auf moderne art neu aufgelegt, in einem spiel mit der durchdringung von körpern und materialien mit gegensätzlichen eigenschaften. In Pyra werden die härte und die strenge der innenarchitektur durch den dünnen stoff mit leinenoptik abgemildert, sodass ein gefühl von gleichgewicht entsteht. Mit ihren neutralen farbtönen kann sich Pyra einfach an jeglichen stil der umgebung anpassen.

L'abat-jour classique revisité dans un style moderne, jouant avec l'interpénétration de corps et de matériaux aux caractéristiques opposées. En Pyra, la sévérité et la rigueur de l'architecture interne sont adoucies par le tissu fin effet lin, donnant une sensation d'équilibre. Avec ses tons neutres, Pyra peut facilement correspondre à tout style présent dans la pièce.



# PYRA

SUSPENSION



PYRA  
TABLE



# PYRA

TABLE



# PYRA

## SUSPENSION

Lampada a sospensione  
in tessuto color sabbia.  
Struttura interna in tondino  
finitura oro spazzolato.  
Rosone in oro spazzolato.  
Cavo di alimentazione nero 200 cm.  
Lampadina installabile E27 a LED.

Suspension lamp  
in a sand-coloured fabric.  
Inner round bar frame  
with a brushed gold finish.  
Brushed gold ceiling canopy.  
Black 200 cm power supply cord.  
Compatible with E27 LED light bulbs.

Pendelleuchte  
aus sandfarbenem Stoff.  
Innere Struktur aus Rundstahl mit  
goldfarbener gebürsteter Ausführung.  
Baldachin goldfarben, gebürstet.  
Stromkabel schwarz, 200 cm.  
Einbaubares Leuchtmittel E27 mit LED.

Suspension en tissu couleur sable.  
Structure intérieure en tube  
rond finition or brossé.  
Rosace en doré brossé.  
Câble d'alimentation noir 200 cm.  
Possibilité d'installer 1 ampoule LED E27.

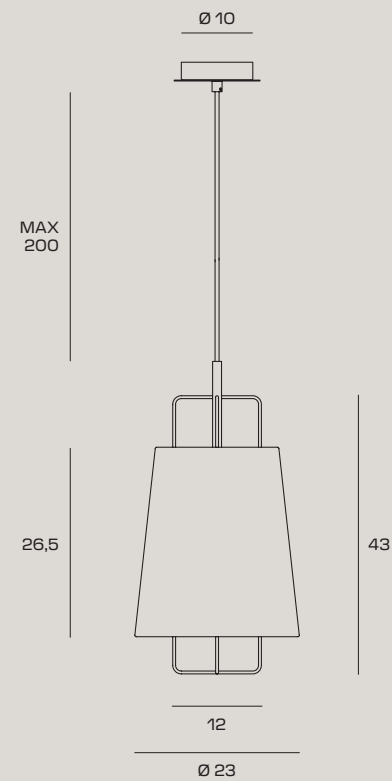

CODE 1744.320

COLOR  Gold

### LIGHT SOURCE

 Source E27 LED | Power 1 x max 20w  
Max bulb size: Ø80xH120mm



# PYRA

## TABLE

Lampada da tavolo  
in tessuto color sabbia.  
Struttura interna in tondino  
finitura oro spazzolato.  
Base in oro spazzolato.  
Cavo di alimentazione nero 150 cm.  
Lampadina installabile E27  
a LED dimmerabile.

Table lamp  
in a sand-coloured fabric.  
Inner round bar frame  
with a brushed gold finish.  
Brushed gold base.  
Black 150 cm power supply cord.  
Dimmable E27  
LED light bulbs.

Tischleuchte  
aus sandfarbenem Stoff.  
Innere Struktur aus Rundstahl mit  
goldfarbener gebürsteter Ausführung.  
Bügel goldfarben, gebürstet.  
Stromkabel schwarz, 150 cm.  
Einbaubares Leuchtmittel E27  
mit LED, dimmbar.

Lampe de table en tissu couleur sable.  
Structure intérieure en tube  
rond finition or brossé.  
Base en finition en or brossé.  
Câble d'alimentation noir 150 cm.  
Possibilité d'installer 1 ampoule  
LED E27 dimmable.

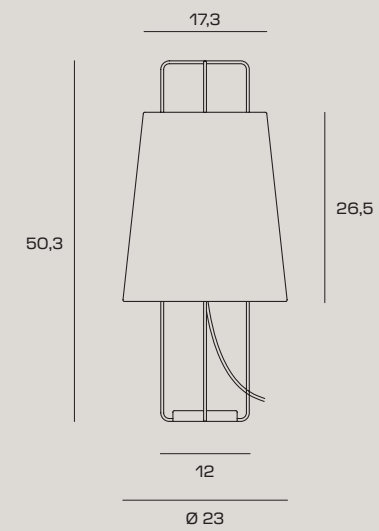

CODE 1744.314

COLOR  Gold

### LIGHT SOURCE

 Source E27 LED DIMMABLE | Power 1 x max 20w  
Max bulb size: Ø80xH120mm



NOT AVAILABLE

[www.miloox.com](http://www.miloox.com)  
[www.miloox.it](http://www.miloox.it)

INDEX

miloox®

# INDEX

miloox

1744.12	EBE	562
1744.13	EBE	562
1744.14	ADONE	570
1744.15	ADONE	570
1744.17	FIFTY	388
1744.17.Black	FIFTY	388
1744.17.AC	FIFTY	388
1744.18	FIFTY	389
1744.18.Black	FIFTY	389
1744.18.AC	FIFTY	389
1744.34	BOMBO	374
1744.35	BOMBO	378
1744.37	BOMBO	381
1744.62	JUGEN	76
1744.63	JUGEN	70
1744.64	JUGEN	68
1744.65	JUGEN	75
1744.66	JUGEN	73
1744.67	JUGEN	74
1744.68	JUGEN	69
1744.70	JUGEN	67
1744.71	JUGEN	77
1744.72	JUGEN	71
1744.73	JUGEN	72
1744.88	X-RAY	504
1744.90	X-RAY	506
1744.97	X-RAY	505
1744.98	POMI'	117
1744.101	POMI'	116
1744.104	POMI'	119
1744.105	POMI'	118
1744.108	SAMOI	635-642
1744.109	SAMOI	636-642
1744.110	SAMOI	637-642
1744.124	BOMBO	379
1744.125	BOMBO	380
1744.126	BOMBO	376
1744.127	BOMBO	377
1744.139	ALADINO	453
1744.141	ALADINO	454
1744.144	ALADINO	456
1744.149	ALADINO	458

1744.150	LUNAR	397
1744.151	LUNAR	398
1744.152	LUNAR	399
1744.164	COSMO	219
1744.165	COSMO	223
1744.167	COSMO	222
1744.168	COSMO	218
1744.169	COSMO	221
1744.171	COSMO	220
1744.172	ALADINO	460
1744.175	MIKADO	326
1744.176	MIKADO	327
1744.177	MIKADO	328
1744.178	MIKADO	329
1744.187	MOSE	182
1744.188	MOSE	182
1744.189	MOSE	182
1744.190	MOSE	182
1744.191	MOSE	182
1744.192	MOSE	182
1744.193	MOSE	182
1744.194	MOSE	182
1744.195	MOSE	182
1744.196	MOSE	180
1744.197	MOSE	181
1744.198	JUGEN	76
1744.199	JUGEN	70
1744.200	JUGEN	68
1744.201	JUGEN	75
1744.202	JUGEN	73
1744.203	JUGEN	74
1744.204	JUGEN	69
1744.205	JUGEN	67
1744.206	JUGEN	77
1744.207	JUGEN	71
1744.208	JUGEN	72
1744.215	NEORETRO	414
1744.216	NEORETRO	415
1744.217	NEORETRO	413
1744.218	MIKADO	326
1744.219	MIKADO	327
1744.220	MIKADO	328

# INDEX

miloox

1744.221	MIKADO	329
1744.239	GRAAL	662
1744.240	GRAAL	663
1744.241	GRAAL	658
1744.242	GRAAL	659
1744.243	GRAAL	660
1744.244	GRAAL	661
1744.245	GRAAL	657
1744.253	FUJI	345
1744.254	FUJI	346
1744.255	FUJI	347
1744.256	FUJI	343
1744.257	FUJI	344
1744.269	POMI'	117
1744.270	POMI'	116
1744.271	POMI'	119
1744.272	POMI'	118
1744.284	DOM	255
1744.285	DOM	254
1744.286	DOM	253
1744.287	DOM	252
1744.289	DOM	258
1744.290	DOM	259
1744.291	DOM	256
1744.292	DOM	257
1744.293	KLOE'	615
1744.294	KIM	621
1744.296	LUNAR	399
1744.302	CAMELY	286
1744.303	CAMELY	287
1744.304	CAMELY	281
1744.305	CAMELY	284
1744.306	CAMELY	285
1744.307	CAMELY	282
1744.308	CAMELY	283
1744.309	CAMELY	288
1744.310	CAMELY	289
1744.311	BUBLE	150
1744.312.Gold	DROP	357
1744.312.Black	DROP	357
1744.313.Blusky	FRIDA	431
1744.313.Lightgreen	FRIDA	431

1744.313.Sand	FRIDA	431
1744.314	PYRA	673
1744.315.Gold	WIRE	235
1744.315.Black	WIRE	235
1744.316.Gold	DROP	356
1744.316.Black	DROP	356
1744.317.Blusky	FRIDA	430
1744.317.Lightgreen	FRIDA	430
1744.317.Sand	FRIDA	430
1744.318	BUBLE	146
1744.319.Gold	WIRE	234
1744.319.Black	WIRE	234
1744.320	PYRA	672
1744.321	AMANITA	583
1744.322	SETTI	589
1744.323	MUG	607
1744.324	MUG	608
1744.325	MUG	609
1744.326	MUG	604
1744.327	MUG	605
1744.328	MUG	606
1744.329	KIKA	32
1744.330	KIKA	33
1744.331	KIKA	36
1744.332	KIKA	37
1744.333	KIKA	34
1744.334	KIKA	35
1744.335	KIKA	31
1744.336	BUBLE	151
1744.337	BUBLE	152
1744.338	BUBLE	153
1744.339	BUBLE	148
1744.340	BUBLE	149
1744.341	BUBLE	155
1744.342	BUBLE	154
1744.343	BUBLE	147
1744.344	LINGOTTO	101
1744.345	LINGOTTO	105
1744.346	LINGOTTO	102
1744.347	LINGOTTO	103
1744.348	LINGOTTO	104
1744.349	LINGOTTO	99

# INDEX

miloox

1744.350	LINGOTTO	100
1744.351	LINGOTTO	98
1744.352	JOTTO	552
1744.354	JOTTO	548
1744.355	JOTTO	549
1744.356	JOTTO	553
1744.357	JOTTO	550
1744.358	JOTTO	542
1744.360	KIKA	38
1744.361	KIKA	39
1744.362	BUBLE	150
1744.363	BUBLE	146
1744.364	BUBLE	151
1744.365	BUBLE	152
1744.366	BUBLE	153
1744.367	BUBLE	148
1744.368	BUBLE	149
1744.369	BUBLE	155
1744.370	BUBLE	154
1744.371	BUBLE	147
1744.372	MIKADO	326
1744.373	MIKADO	327
1744.374	MIKADO	328
1744.375	MIKADO	329
1744.376	MIKADO	326
1744.377	MIKADO	327
1744.378	MIKADO	328
1744.379	MIKADO	329
1744.380	DOMU	202
1744.381	DOMU	203
1744.382	DOMU	200
1744.383	DOMU	201
1744.384	DOMU	198
1744.385	DOMU	199

MONTATURE WALL/CEILING CUPS /MONTAGEN / MONTAGE		
1744.M.37	EBE E ADONE	577
1744.M.38	EBE E ADONE	577
1744.M.39	EBE E ADONE	577
1744.M.40	EBE E ADONE	577
1744.M.41	EBE E ADONE	577
1744.M.52	SAMOI	643
1744.M.53	SAMOI	643
1744.M.54	SAMOI	643
1744.M.55	SAMOI	643
1744.M.131	X-RAY	511
1744.M.132	X-RAY	511
1744.M.133	X-RAY	511
1744.M.183	MOSE	183
1744.M.184	MOSE	183
1744.M.185	MOSE	183
1744.M.186	MOSE	183
1744.M.187	X-RAY	511
1744.M.188	JOTTO	
COMPOSIZIONI / COMPOSITIONS / KOMPOSITIONEN / COMPOSITIONS		
1744.40.KIT	EBE e ADONE	575
1744.107.KIT	X-RAY	507
1744.116.KIT	SAMOI	639
1744.118.KIT	X-RAY	516
1744.119.KIT	X-RAY	517
1744.120.KIT	X-RAY	515
1744.121.KIT	X-RAY	513
1744.123.KIT	BOMBO	375
1744.137.KIT	X-RAY	509
1744.145.KIT	X-RAY	514
1744.146.KIT	X-RAY	512
1744.223.KIT	MOSE	174
1744.224.KIT	MOSE	174
1744.225.KIT	MOSE	174
1744.226.KIT	MOSE	175
1744.227.KIT	MOSE	175

# INDEX

miloox

1744.228.KIT	MOSE	175
1744.229.KIT	MOSE	176
1744.230.KIT	MOSE	176
1744.231.KIT	MOSE	176
1744.232.KIT	MOSE	177
1744.233.KIT	MOSE	178
1744.234.KIT	MOSE	179
1744.235.KIT	EBE	563
1744.236.KIT	EBE	563
1744.237.KIT	ADONE	571
1744.238.KIT	ADONE	571
1744.299.KIT	SAMOI	639
1744.300.KIT	SAMOI	640
1744.301.KIT	SAMOI	641
KIT.M.1	X-RAY	512
KIT.M.2	X-RAY	513
KIT.M.3	X-RAY	514
KIT.M.4	X-RAY	515
KIT.M.5	X-RAY	517
KIT.M.6	X-RAY	516
KIT.M.7	X-RAY	507
KIT.M.8	X-RAY	507
KIT.M.9	X-RAY	507
KIT.M.10	X-RAY	507
KIT.M.11	X-RAY	508
KIT.M.12	X-RAY	508
KIT.M.13	X-RAY	508
KIT.M.14	X-RAY	508
KIT.M.15	X-RAY	509
KIT.M.16	X-RAY	509
KIT.M.17	X-RAY	509
KIT.M.18	X-RAY	505
KIT.M.19	X-RAY	506
KIT.M.20	X-RAY	504
KIT.M.21	JOTTO	544
KIT.M.22	JOTTO	545
KIT.M.23	JOTTO	546
KIT.M.24	JOTTO	547
KIT.M.25	JOTTO	542
KIT.M.26	JOTTO	543

VETRO GLASS / GLAS / VERRE		
1744.V.12	EBE	
1744.V.13	EBE	
1744.V.14	ADONE	
1744.V.15	ADONE	
1744.V.16	FIFTY	
1744.V.19	FIFTY	
1744.V.20	LUNAR	
1744.V.34	BOMBO	
1744.V.35	BOMBO	
1744.V.62	JUGEN Ø 30	
1744.V.63	JUGEN Ø 15	
1744.V.64	JUGEN Ø 20	
1744.V.66	JUGEN Ø 25	
1744.V.98	POMI' Ø 10	
1744.V.118	X-RAY	510
1744.V.118.GOLD	X-RAY	510
1744.V.119	X-RAY	510
1744.V.119.COPPER	X-RAY	510
1744.V.120	X-RAY	510
1744.V.120.BRONZE	X-RAY	510
1744.V.139	ALADINO Ø 15	
1744.V.150	LUNAR Ø 12	
1744.V.164	COSMO/MIKADO	
1744.V.175	MIKADO	
1744.V.187	MOSE	
1744.V.213	NEORETRO	
1744.V.253	FUJI	
1744.V.284	DOM	
1744.V.310	CAMELY	



Viale dell'Industria, 21  
20037 Paderno Dugnano (MI) - Italy  
Tel. +39 02 9104958 r.a. - +39 02 9105178  
Fax +39 02 9185542  
[info@sforzinilluminazione.com](mailto:info@sforzinilluminazione.com)  
[www.sforzinilluminazione.com](http://www.sforzinilluminazione.com)

miloox®

**AD**

Davide Negri Studio

**Graphic**

Red Apple International

**Photo**

Paolo Volontè

